

Power Transducer Series L-UNIT

FREQUENCY TRANSDUCER

Functions & Features

- Providing a DC output signal in proportion to deviation (± 5 Hz) from center frequency (50 Hz or 60 Hz)
- DC output containing little ripple is ideal for computer input
- Isolation up to 2000 V AC
- Highdensity mounting

Typical Applications

- Centralized monitoring and control of power management system in manufacturing facility or building
- Measuring frequency for UPS

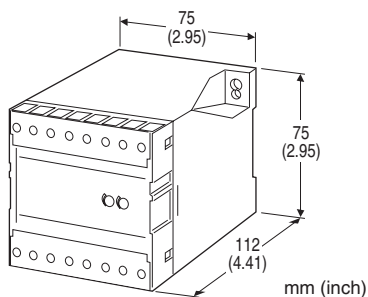

MODEL: LHZ-[1][2][3]-[4][5]

ORDERING INFORMATION

- Code number: LHZ-[1][2][3]-[4][5]
- Specify a code from below for each [1] through [5].
(e.g. LHZ-11A-C/Q)
- Special output range (For codes Z & 0)
 - Specify the specification for option code /Q
(e.g. /C01/S01)

[1] FREQUENCY

- 1: 45 - 55 Hz
- 2: 55 - 65 Hz
- 3: 45 - 65 Hz

[2] INPUT

- 1: 110 V AC
- 2: 220 V AC

[3] OUTPUT

Current

- A: 4 - 20 mA DC (Load resistance 600 Ω max.)
- D: 0 - 20 mA DC (Load resistance 600 Ω max.)
- E: 0 - 16 mA DC (Load resistance 750 Ω max.)
- F: 0 - 10 mA DC (Load resistance 1200 Ω max.)
- G: 0 - 1 mA DC (Load resistance 12 k Ω max.)
- J: 0 - 5 mA DC (Load resistance 2400 Ω max.)
- Z: Specify current (See OUTPUT SPECIFICATIONS)

Voltage

- 1: 0 - 10 mV DC (Load resistance 10 k Ω min.)
- 2: 0 - 100 mV DC (Load resistance 100 k Ω min.)
- 3: 0 - 1 V DC (Load resistance 1000 Ω min.)
- 4: 0 - 10 V DC (Load resistance 10 k Ω min.)
- 5: 0 - 5 V DC (Load resistance 5000 Ω min.)
- 6: 1 - 5 V DC (Load resistance 5000 Ω min.)
- 0: Specify voltage (See OUTPUT SPECIFICATIONS)

[4] AUXILIARY POWER SUPPLY

AC Power

- B: 100 V AC
- C: 110 V AC
- D: 115 V AC
- F: 120 V AC
- G: 200 V AC
- H: 220 V AC
- J: 240 V AC

DC Power

- R: 24 V DC
- V: 48 V DC
- P: 110 V DC

[5] OPTIONS

- blank: none
- /Q: With options (specify the specification)

SPECIFICATIONS OF OPTION: Q (multiple selections)

COATING (For the detail, refer to M-System's web site.)

- /C01: Silicone coating
- /C02: Polyurethane coating
- /C03: Rubber coating

TERMINAL SCREW MATERIAL

- /S01: Stainless steel

GENERAL SPECIFICATIONS

Construction: Stand-alone; terminal access at the front

Connection: M3.5 screw terminals (torque 0.8 N·m)

Screw terminal: Nickel-plated steel (standard) or stainless steel

Housing material: Flame-resistant resin (black)

Isolation: Input to output to auxiliary power

(input to output to auxiliary power to ground)

Computation: One-shot

Impulse withstand voltage: 1.2 / 50 μ sec., ± 5 kV

Overrange output: Approx. -10 to +120 % at 1 - 5 V

(input to output or ground)

Zero adjustment: -5 to +5 % (front)

Span adjustment: 95 to 105 % (front)

INPUT SPECIFICATIONS

Input burden: 1 VA

Overload capacity: 150 % of rating for 10 sec., 120 % continuous

Operational range: 85 - 120 % of rating

OUTPUT SPECIFICATIONS

■ **DC Current:** 0 - 20 mA DC

Minimum span: 1 mA

Offset: Max. 1.5 times span

Load resistance: Output drive 12 V max.

■ **DC Voltage:** 0 - 12 V DC

Minimum span: 5 mV

Offset: Max. 1.5 times span

Load resistance: Output drive 1 mA max.; at ≥ 0.5 V

■ **OPERATION DIAGRAM (example)**

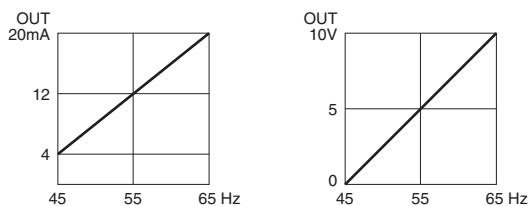

Remark: When there is no input voltage, the transducer outputs as negative (-) overrange.

INSTALLATION

Auxiliary power supply

• **AC:** Operational voltage range: rating -15/+10 %, 50/60 Hz, approx. 2 VA

• **DC:** Operational voltage range: rating ± 10 %, or 85 - 150 V for 110 V rating, ripple 10 %p-p max., approx. 2 W (18 mA at 110 V)

Operating temperature: -10 to +55°C (14 to 131°F)

Operating humidity: 30 to 85 %RH (non-condensing)

Mounting: Surface or DIN rail

Weight: 300 g (0.66 lb)

PERFORMANCE in percentage of span

Accuracy: ± 1 % (at 23°C ± 10 °C or 73.4°F ± 18 °F)

Response time: ≤ 1 sec. (0 - 100 % ± 1 %)

Ripple: 0.5 %p-p max.

Line voltage effect: ± 0.1 % over voltage range

Insulation resistance: ≥ 100 M Ω with 500 V DC

Dielectric strength: 2000 V AC @1 minute

CONNECTION DIAGRAM

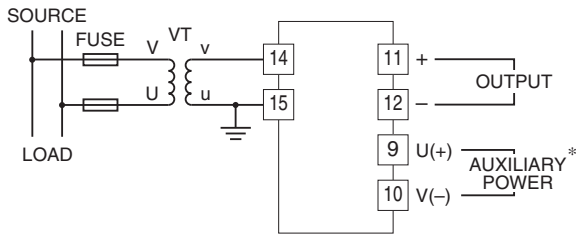

*The transducer can be powered from the input voltage when the voltage is sufficiently stable and meets other supply voltage requirements.

EXTERNAL DIMENSIONS & TERMINAL ASSIGNMENTS unit: mm (inch)

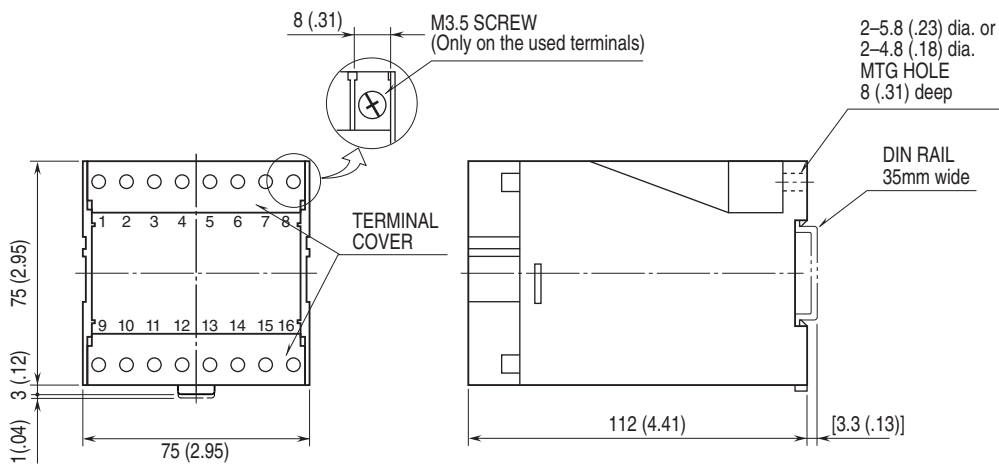

•When mounting, no extra space is needed between units.

MOUNTING REQUIREMENTS unit: mm (inch)

■ M5 SCREWS

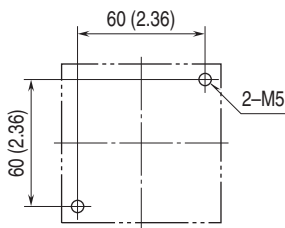

■ M4 SCREWS

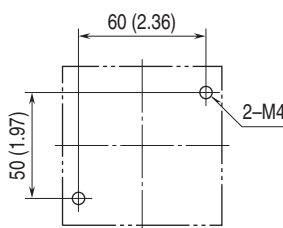

Specifications are subject to change without notice.