

NJ8821

FREQUENCY SYNTHESISER (MICROPROCESSOR INTERFACE) WITH RESETTABLE COUNTERS

The NJ8821 is a synthesiser circuit fabricated on the GPS CMOS process and is capable of achieving high sideband attenuation and low noise performance. It contains a reference oscillator, 11-bit programmable reference divider, digital and sample-and-hold comparators, 10-bit programmable 'M' counter, 7-bit programmable 'A' counter and the necessary control and latch circuitry for accepting and latching the input data.

Data is presented as eight 4-bit words under external control from a suitable microprocessor..

It is intended to be used in conjunction with a two-modulus prescaler such as the SP8710 series to produce a universal binary coded synthesiser.

The NJ8821 is available in Plastic DIL (DP) and Miniature Plastic DIL (MP) packages, both with operating temperature range of -30°C to +70°C. The NJ8821MA is available only in Ceramic DIL package with operating temperature range of -40°C to +85°C.

FEATURES

- Low Power Consumption
- Microprocessor Compatible
- High Performance Sample and Hold Phase Detector
- >10MHz Input Frequency

ORDERING INFORMATION

- NJ8821 BA DP** Plastic DIL Package
NJ8821 BA MP Miniature Plastic DIL Package
NJ8821 MA DG Ceramic DIL Package

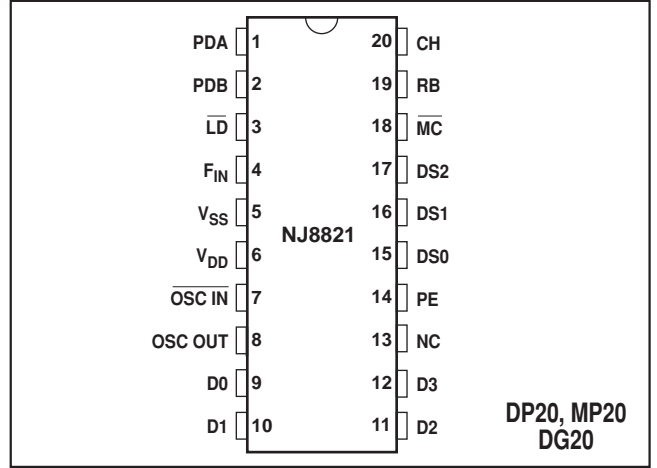

Fig.1 Pin connections - top view

ABSOLUTE MAXIMUM RATINGS

Supply voltage, $V_{DD}-V_{SS}$	-0.5V to 7V
Input voltage	7V
Open drain output, pin 3	$V_{SS}-0.3V$ to $V_{DD}+0.3V$
All other pins	-65°C to +150°C
Storage temperature	(DG package, NJ8821MA)
	-55°C to +125°C
Storage temperature	(DP and MP packages, NJ8821)

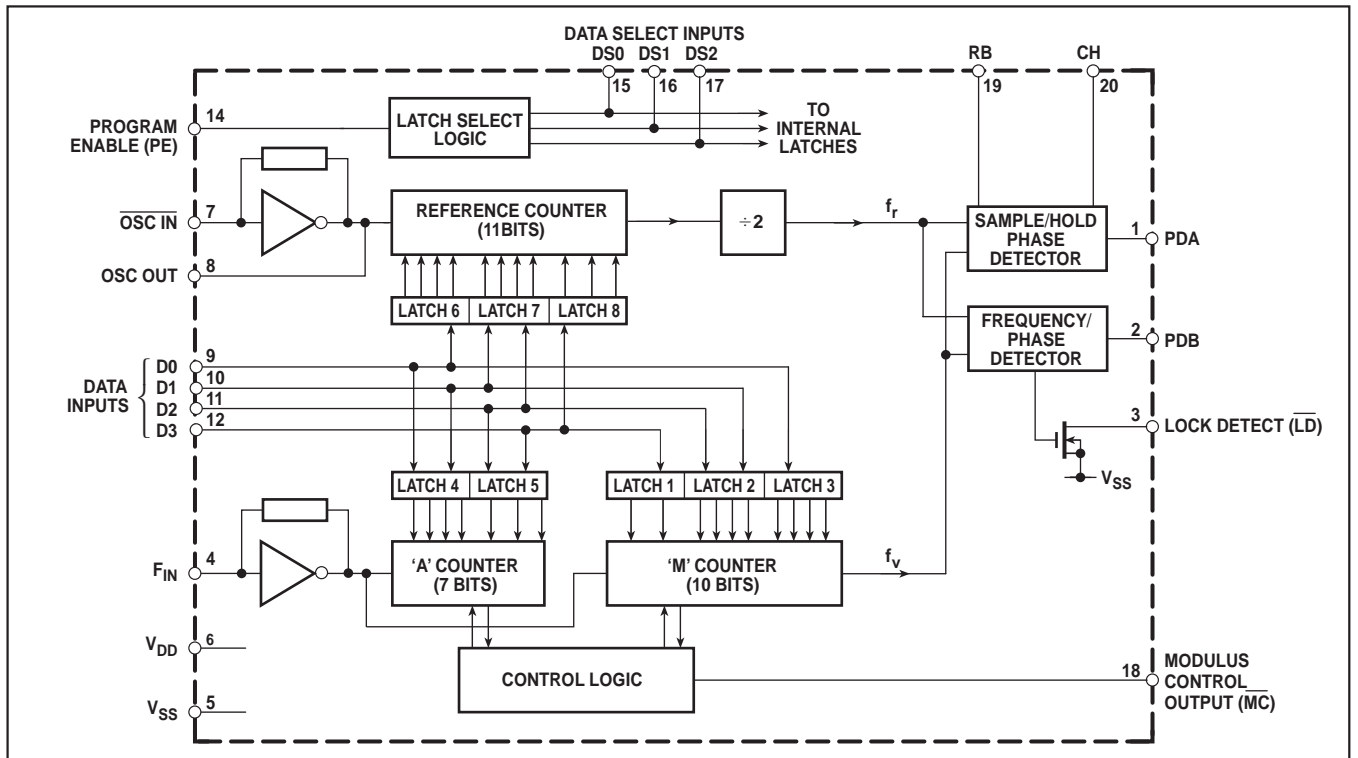

Fig.2 Block diagram

NJ8821

ELECTRICAL CHARACTERISTICS AT $V_{DD} = 5V$

Test conditions unless otherwise stated:

$V_{DD} - V_{SS} = 5V \pm 0.5V$. Temperature range NJ8821 BA: $-30^{\circ}C$ to $+70^{\circ}C$; NJ8821 MA: $-40^{\circ}C$ to $+85^{\circ}C$

DC Characteristics

Characteristic	Value			Units	Conditions
	Min.	Typ.	Max.		
Supply current		3.5	5.5	mA	$f_{OSC}, f_{FIN} = 10MHz$ } 0 to 5V square wave $f_{OSC}, f_{FIN} = 1.0MHz$ }
		0.7	1.5	mA	
OUTPUT LEVELS					
Modulus Control Output (\overline{MC})					
High level	4.6			V	$I_{SOURCE} = 1mA$ $I_{SINK} = 1mA$
Low level			0.4	V	
Lock Detect Output (\overline{LD})					
Low level			0.4	V	$I_{SINK} = 4mA$
Open drain pull-up voltage			7	V	
PDB Output					
High level	4.6			V	$I_{SOURCE} = 5mA$ $I_{SINK} = 5mA$
Low level			0.4	V	
3-state leakage current			± 0.1	μA	
INPUT LEVELS					
Data Inputs (D0-D3)					
High level	4.25			V	TTL compatible See note 1
Low level			0.4	V	
Program Enable Input (PE)					
High level	4.25			V	
Low level			0.75	V	
Data Select Inputs (DS0-DS2)					
High level	4.25			V	
Low level			0.75	V	

AC Characteristics

Characteristic	Value			Units	Conditions
	Min.	Typ.	Max.		
F_{IN} and \overline{OSC} IN input level	200			mVRMS	10MHz AC-coupled sinewave Input squarewave V_{DD} to V_{SS} , See note 4.
Max. operating frequency, f_{FIN} and f_{OSC}	10.6			MHz	
Propagation delay, clock to \overline{MC}		30	50	ns	See note 2.
Strobe pulse width, $t_{W(ST)}$	2			μs	
Data set-up time, t_{DS}	1			μs	
Data hold time, t_{DH}	1			μs	
Latch address set-up time, t_{SE}	1			μs	
Latch address hold time, t_{HE}	1			μs	
Digital phase detector propagation delay		500		ns	See note 3.
Gain programming resistor, RB	5			k Ω	
Hold capacitor, CH			1	nF	
Output resistance, PDA			5	k Ω	
Digital phase detector gain		0.4		V/Rad	

NOTES

1. Data inputs have internal pull-up resistors to enable them to be driven from TTL outputs.
2. All counters have outputs directly synchronous with their respective clock rising edges.
3. The finite output resistance of the internal voltage follower and 'on' resistance of the sample switch driving this pin will add a finite time constant to the loop. An external 1nF hold capacitor will give a maximum time constant of 5 μs , typically.
4. Operation at up to 15MHz is possible with a full logic swing but is not guaranteed.

PIN DESCRIPTIONS

Pin no.	Name	Description
1	PDA	Analog output from the sample and hold phase comparator for use as a 'fine' error signal. Output at $(V_{DD}-V_{SS})/2$ when the system is in lock. Voltage increases as f_v phase lead increases; voltage decreases as f_r phase lead increases. Output is linear over only a narrow phase window, determined by gain (programmed by RB).
2	PDB	Three-state output from the phase/frequency detector for use as a 'coarse' error signal. $f_v > f_r$ or f_v leading: positive pulses with respect to the bias point V_{BIAS} $f_v < f_r$ or f_r leading: negative pulses with respect to the bias point V_{BIAS} $f_v = f_r$ and phase error within PDA window: high impedance.
3	\overline{LD}	An open-drain lock detect output at low level when phase error is within PDA window (in lock); high impedance at all other times.
4	F_{IN}	The input to the main counters, normally driven from a prescaler, which may be AC-coupled or, when a full logic swing is available, may be DC-coupled.
5	V_{SS}	Negative supply (ground).
6	V_{DD}	Positive supply.
7, 8	$\overline{OSC IN}/$ $OSC OUT$	These pins form an on-chip reference oscillator when a series resonant crystal is connected across them. Capacitors of appropriate value are also required between each end of the crystal and ground to provide the necessary additional phase shift. An external reference signal may, alternatively, be applied to $\overline{OSC IN}$. This may be a low-level signal, AC-coupled, or if a full logic swing is available it may be DC-coupled. The program range of the reference counter is 3 to 2047, with the division ratio being twice the programmed number.
9,10, 11, 12	D0-D3	Data on these inputs is transferred to the internal data latches during the appropriate data read time slot. D3 is MSB, D0 is LSB.
13	NC	No connection
14	PE	This pin is used as a strobe for the data. A logic '1' on this pin transfers data from the D0-D3 pins to the internal latch addressed by the data select (DS0-DS2) pins. A logic '0' disables the data inputs.
15, 16, 17	DS0-DS2	Data select inputs for addressing the internal data latches
18	\overline{MC}	Modulus control output for controlling an external dual-modulus prescaler. \overline{MC} will be low at the beginning of a count cycle and will remain low until the 'A' counter completes its cycle. \overline{MC} then goes high and remains high until the 'M' counter completes its cycle, at which point both 'A' and 'M' counters are reset. This gives a total division ratio of $MP+A$, where P and $P+1$ represent the dual-modulus prescaler values. The program range of the 'A' counter is 0-127 and therefore can control prescalers with a division ratio up to and including $\div 128/129$. The programming range of the 'M' counter is 8-1023 and, for correct operation, $M \geq A$. Where every possible channel is required, the minimum total division ratio should be $P^2 - P$.
19	RB	An external sample and hold phase comparator gain programming resistor should be connected between this pin and V_{SS} .
20	CH	An external hold capacitor should be connected between this pin and V_{SS} .

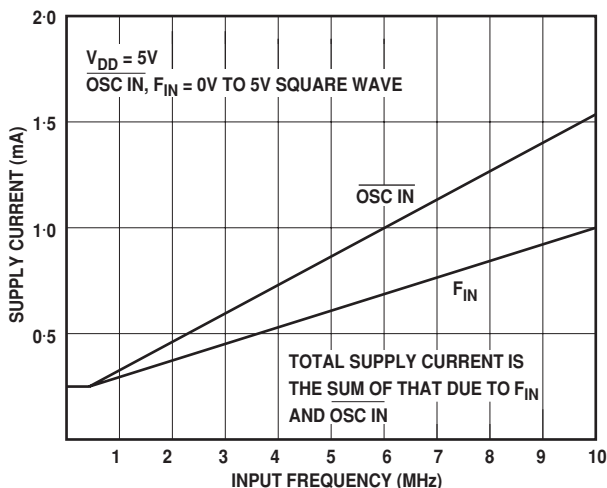

Fig. 3 Typical supply current v. input frequency

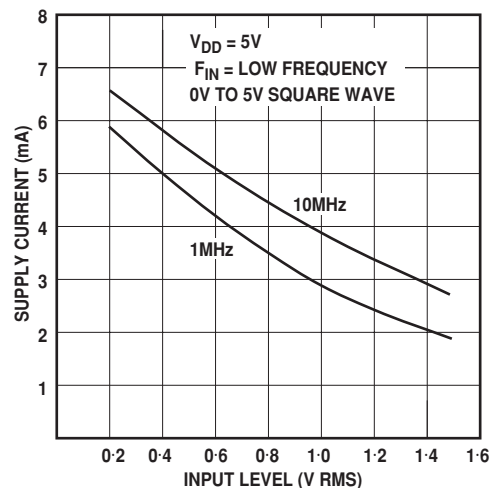

Fig. 4 Typical supply current v. input level, $\overline{OSC IN}$

PROGRAMMING

Timing is generated externally, normally from a microprocessor, and allows the user to change the data in selected latches as defined by the data map Fig.5. The PE pin is used as a strobe for the data: taking PE high causes data to be transferred from the data pins (D0-D3) into the addressed latch. Following the falling edge of PE, the data is retained in the addressed latch and the data inputs are disabled. Data transfer from all internal latches into the counters occurs simultaneously with the transfer of data into latch 1, which would therefore normally be the last latch addressed during each channel change. Timing information for this mode of operation is given in Fig. 6.

When re-programming, a reset to zero state is followed by reloading with the new counter values. This means that the synthesiser loop lock-up time is well defined and less than

10ms. If shorter lock-up times are required when making only small changes in frequency, the GPS NJ8823 (with non-resettable counters) should be considered.

WORD	DS2	DS1	DS0	D3	D2	D1	D0
1	0	0	0	M1	M0	-	-
2	0	0	1	M5	M4	M3	M2
3	0	1	0	M9	M8	M7	M6
4	0	1	1	A3	A2	A1	A0
5	1	0	0	-	A6	A5	A4
6	1	0	1	R3	R2	R1	R0
7	1	1	0	R7	R6	R5	R4
8	1	1	1	-	R10	R9	R8

Fig. 5 Data map

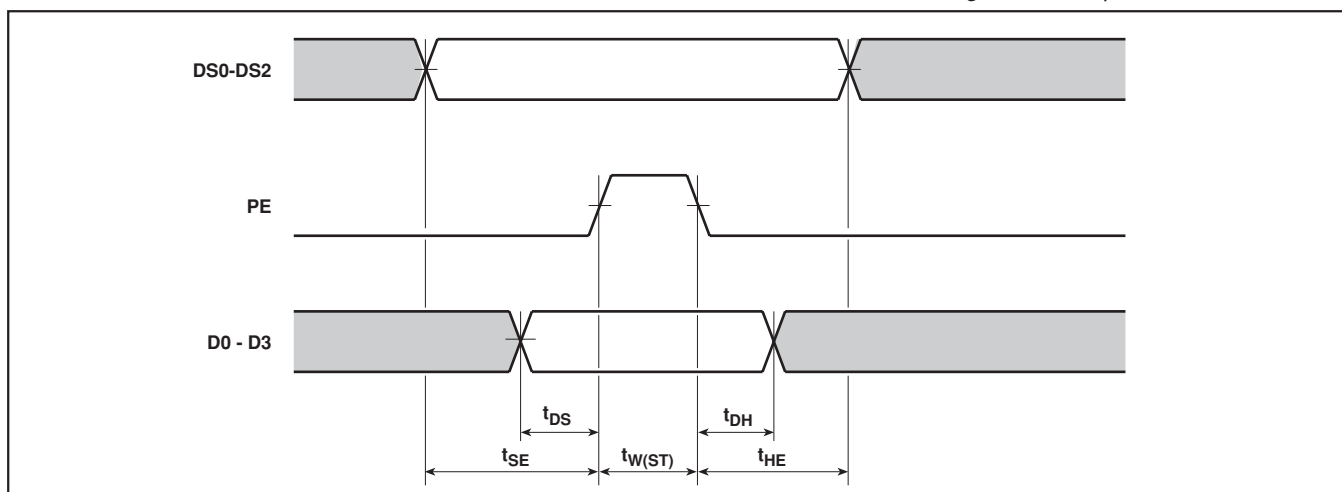

Fig. 6 Timing diagram

PHASE COMPARATORS

The digital phase/frequency detector drives a three-state output, PDB, which provides a 'coarse' error signal to enable fast switching between channels. The PDB output is active until the phase error is within the sample and hold phase detector, PDA, window, when PDB becomes high impedance. Phase-lock is indicated at this point by a low level on \overline{LD} . The sample and hold phase detector provides a 'fine' error signal to give further phase adjustment and to hold the loop in lock.

An internally generated ramp, controlled by the digital output from both the reference and main divider chains, is sampled at the reference frequency to give the 'fine' error signal, PDA. When in phase lock, this output would be typically at $(V_{DD} - V_{SS})/2$ and any offset from this would be proportional to phase error. The relationship between this offset and the

phase error is the phase comparator gain, which is programmable with an external resistor, R_B. An internal 50pF capacitor is used in the sample and hold comparator.

CRYSTAL OSCILLATOR

When using the internal oscillator, the stability may be enhanced at high frequencies by the inclusion of a resistor between pin 8 (OSC OUT) and the other components. A value of 150-270Ω is advised.

PROGRAMMING/POWER UP

Data and signal input pins should not have input applied to them prior to the application of V_{DD}, as otherwise latch-up may occur.



HEADQUARTERS OPERATIONS
GEC PLESSEY SEMICONDUCTORS
 Cheney Manor, Swindon,
 Wiltshire SN2 2QW, United Kingdom.
 Tel: (0793) 518000
 Fax: (0793) 518411

GEC PLESSEY SEMICONDUCTORS
 P.O. Box 660017
 1500 Green Hills Road,
 Scotts Valley, California 95067-0017,
 United States of America.
 Tel: (408) 438 2900
 Fax: (408) 438 5576

CUSTOMER SERVICE CENTRES

- **FRANCE & BENELUX** Les Ulis Cedex Tel: (1) 64 46 23 45 Fax : (1) 64 46 06 07
- **GERMANY** Munich Tel: (089) 3609 06-0 Fax : (089) 3609 06-55
- **ITALY** Milan Tel: (02) 66040867 Fax: (02) 66040993
- **JAPAN** Tokyo Tel: (03) 5276-5501 Fax: (03) 5276-5510
- **NORTH AMERICA** Scotts Valley, USA Tel (408) 438 2900 Fax: (408) 438 7023.
- **SOUTH EAST ASIA** Singapore Tel: (65) 3827708 Fax: (65) 3828872
- **SWEDEN** Stockholm, Tel: 46 8 702 97 70 Fax: 46 8 640 47 36
- **TAIWAN, ROC** Taipei Tel: 886 2 5461260. Fax: 886 2 71900260
- **UK, EIRE, DENMARK, FINLAND & NORWAY**
 Swindon Tel: (0793) 518510 Fax : (0793) 518582

These are supported by Agents and Distributors in major countries world-wide.

© GEC Plessey Semiconductors 1992

This publication is issued to provide information only which (unless agreed by the Company in writing) may not be used, applied or reproduced for any purpose nor form part of any order or contract nor to be regarded as a representation relating to the products or services concerned. No warranty or guarantee express or implied is made regarding the capability, performance or suitability of any product or service. The Company reserves the right to alter without prior knowledge the specification, design or price of any product or service. Information concerning possible methods of use is provided as a guide only and does not constitute any guarantee that such methods of use will be satisfactory in a specific piece of equipment. It is the user's responsibility to fully determine the performance and suitability of any equipment using such information and to ensure that any publication or data used is up to date and has not been superseded. These products are not suitable for use in any medical products whose failure to perform may result in significant injury or death to the user. All products and materials are sold and services provided subject to the Company's conditions of sale, which are available on request.

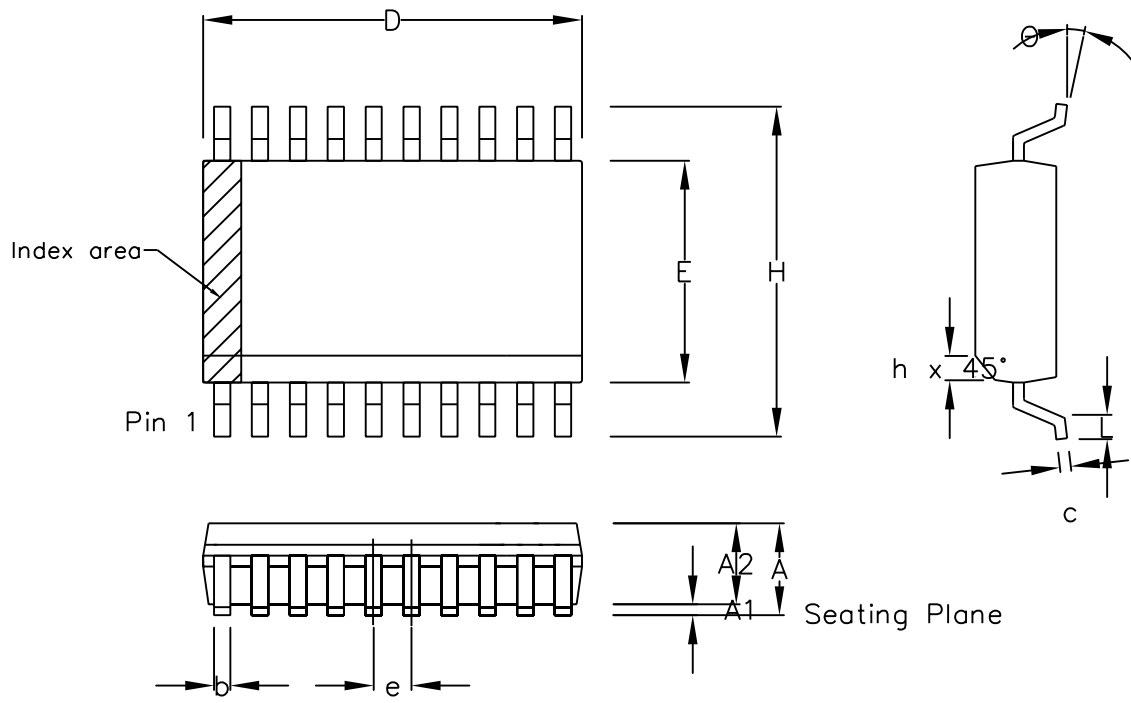

Symbol	Control Dimensions in millimetres			Altern. Dimensions in inches		
	MIN	Nominal	MAX	MIN	Nominal	MAX
A	2.35		2.65	0.093		0.104
A1	0.10		0.30	0.004		0.012
A2	2.25		2.35	0.089		0.092
D	12.60		13.00	0.496		0.512
H	10.00		10.65	0.394		0.419
E	7.40		7.60	0.291		0.299
L	0.40		1.27	0.016		0.050
e	1.27 BSC.			0.050 BSC.		
b	0.33		0.51	0.013		0.020
c	0.23		0.32	0.009		0.013
θ	0°		8°	0°		8°
h	0.25		0.75	0.010		0.029
Pin features						
N	20					
Conforms to JEDEC MS-013AC Iss. C						

Notes:

1. The chamfer on the body is optional. If it not present, a visual index feature, e.g. a dot, must be located within the cross-hatched area.
2. Controlling dimension are in millimeters.
3. Dimension D do not include mould flash, protrusion or gate burrs. These shall not exceed 0.006" per side.
4. Dimension E1 do not include inter-lead flash or protrusion. These shall not exceed 0.010" per side.
5. Dimension b does not include dambar protrusion/intrusion. Allowable dambar protrusion shall be 0.004" total in excess of b dimension.

© Zarlink Semiconductor 2002 All rights reserved.				
ISSUE	1	2	3	
ACN	6746	201941	213098	
DATE	7Apr95	27Feb97	15Jul02	
APPRD.				



		Package Code	DC
Previous package codes		Package Outline for 20 lead SOIC (0.300" Body Width)	
MP / S			
		GPD00015	

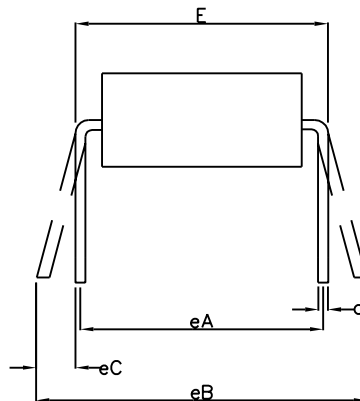
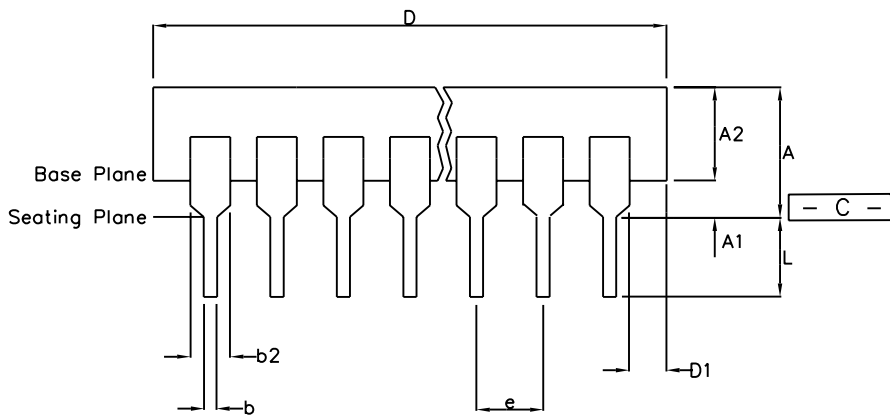
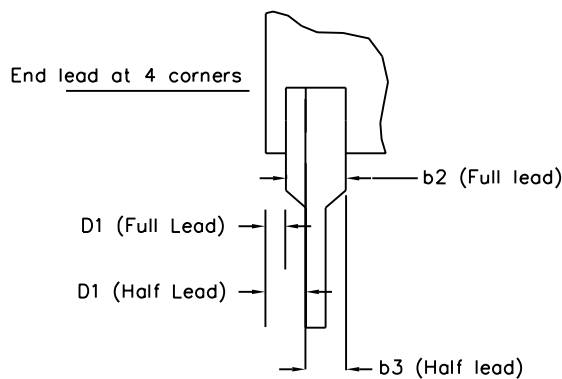
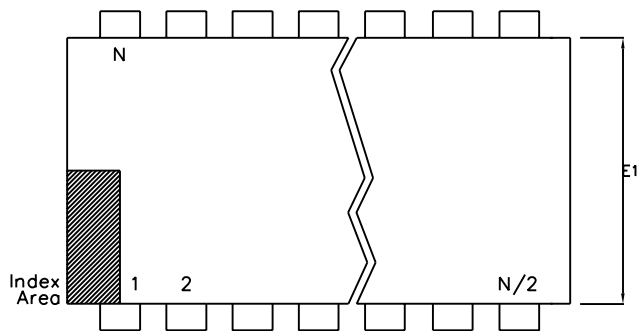

	Min mm	Max mm	Min Inches	Max Inches
A		5.33		0.210
A1	0.38		0.015	
A2	2.92	4.95	0.115	0.195
b	0.36	0.56	0.014	0.022
b2	1.14	1.78	0.045	0.070
b3	n/a	n/a	n/a	n/a
c	0.20	0.36	0.008	0.014
D	24.89	26.92	0.980	1.060
D1	0.13		0.005	
E	7.62	8.26	0.300	0.325
E1	6.10	7.11	0.240	0.280
e	2.54 BSC		0.100 BSC	
eA	7.62 BSC		0.300 BSC	
eB		10.92		0.430
eC	0.00	1.52	0.000	0.060
L	2.92	3.81	0.115	0.150
N	20		20	
Conforms to Jeduc MS-001AD Issue D				

Notes:

1. Dimensions D, D1 & E1 do not include mould flash or protrusions.
2. Dimensions E & eA are measured with leads constrained to be perpendicular to datum $\boxed{- C -}$
3. Dimensions eB & eC are measured with the leads unconstrained
4. Controlling dimensions are Inches. Millimeter conversions are not necessarily exact.
5. N is the maximum of terminal positions.

This drawing supersedes: -
UK drawing # 418/ED/39502/005

© Zarlink Semiconductor 2002 All rights reserved.

ISSUE	1	2		
ACN	202562	213107		
DATE	9Jun97	15Jul02		
APPRD.				



Previous package codes

DP / E

Package Code DA

Package Outline for
20 lead PDIP

GPD00347



**For more information about all Zarlink products
visit our Web Site at
www.zarlink.com**

Information relating to products and services furnished herein by Zarlink Semiconductor Inc. or its subsidiaries (collectively "Zarlink") is believed to be reliable. However, Zarlink assumes no liability for errors that may appear in this publication, or for liability otherwise arising from the application or use of any such information, product or service or for any infringement of patents or other intellectual property rights owned by third parties which may result from such application or use. Neither the supply of such information or purchase of product or service conveys any license, either express or implied, under patents or other intellectual property rights owned by Zarlink or licensed from third parties by Zarlink, whatsoever. Purchasers of products are also hereby notified that the use of product in certain ways or in combination with Zarlink, or non-Zarlink furnished goods or services may infringe patents or other intellectual property rights owned by Zarlink.

This publication is issued to provide information only and (unless agreed by Zarlink in writing) may not be used, applied or reproduced for any purpose nor form part of any order or contract nor to be regarded as a representation relating to the products or services concerned. The products, their specifications, services and other information appearing in this publication are subject to change by Zarlink without notice. No warranty or guarantee express or implied is made regarding the capability, performance or suitability of any product or service. Information concerning possible methods of use is provided as a guide only and does not constitute any guarantee that such methods of use will be satisfactory in a specific piece of equipment. It is the user's responsibility to fully determine the performance and suitability of any equipment using such information and to ensure that any publication or data used is up to date and has not been superseded. Manufacturing does not necessarily include testing of all functions or parameters. These products are not suitable for use in any medical products whose failure to perform may result in significant injury or death to the user. All products and materials are sold and services provided subject to Zarlink's conditions of sale which are available on request.

Purchase of Zarlink's I²C components conveys a licence under the Philips I²C Patent rights to use these components in and I²C System, provided that the system conforms to the I²C Standard Specification as defined by Philips.

Zarlink, ZL and the Zarlink Semiconductor logo are trademarks of Zarlink Semiconductor Inc.

Copyright Zarlink Semiconductor Inc. All Rights Reserved.

TECHNICAL DOCUMENTATION - NOT FOR RESALE
