

1. Mechanical Dimensions:

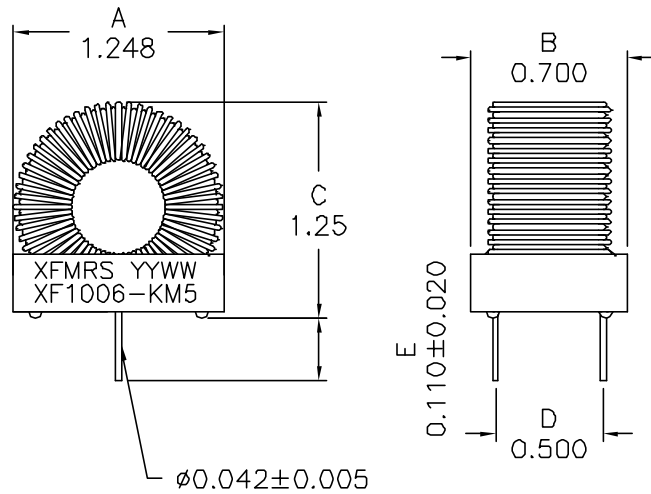

2. Schematic:

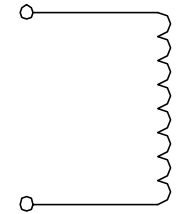

3. Electrical Specifications:

- OCL: 100uH Typ @10KHz, 0.1V
- ISat: 5.0Adc
- DCR: 0.040 Ohms Max
- ETop: 200V-uS
- Energy Storage: 1250uJ Min
- Q: tbd Min @10KHz, 0.1V

Notes:

1. Solderability: Leads shall meet MIL-STD-202, Method 208D for solderability.
2. Flammability: UL94V-0
3. ASTM oxygen index: > 28%
4. Insulation System: Class F 155°C. UL file E151556
5. Operating Temperature Range: All listed parameters are to be within tolerance from -40°C to +85°C
6. Storage Temperature Range: -55°C to +125°C
7. Aqueous wash compatible
8. SMD Lead Coplanarity: ±0.004"(0.102mm)
9. Moisture Sensitivity: Level 3
10. Electrical and mechanical specifications 100% tested
11. RoHS Compliant Component

DOC REV: A/1

XFMRS Inc. www.XFMRS.com		Title: Toroid Choke		
UNLESS OTHERWISE SPECIFIED TOLERANCES: .xxx ±0.010 Dimensions in Inch	P/N: XF1006-KM5		REV. A	
	DWN.	Juan Mao	Feb-25-05	
SHEET 1 OF 1	CHK.	YK Liao	Feb-25-05	
	APP.	BW	Feb-25-05	