

isc Silicon NPN Darlington Power Transistors

BDT61/A/B/C

DESCRIPTION

- DC Current Gain $-h_{FE} = 750(\text{Min}) @ I_C = 1.5\text{A}$
- Collector-Emitter Sustaining Voltage-
: $V_{CEO(\text{SUS})} = 60\text{V}(\text{Min})$ - BDT61; $80\text{V}(\text{Min})$ - BDT61A;
 $100\text{V}(\text{Min})$ - BDT61B; $120\text{V}(\text{Min})$ - BDT61C
- Complement to Type BDT60/A/B/C

APPLICATIONS

- Designed for use in audio amplifier output stages , general purpose amplifier and high speed switching applications

ABSOLUTE MAXIMUM RATINGS($T_a=25^\circ\text{C}$)

SYMBOL	PARAMETER	VALUE	UNIT	
V_{CBO}	Collector-Base Voltage	BDT61	60	V
		BDT61A	80	
		BDT61B	100	
		BDT61C	120	
V_{CEO}	Collector-Emitter Voltage	BDT61	60	V
		BDT61A	80	
		BDT61B	100	
		BDT61C	120	
V_{EBO}	Emitter-Base Voltage	5	V	
I_C	Collector Current-Continuous	4	A	
I_B	Base Current	0.1	A	
P_C	Collector Power Dissipation $T_a=25^\circ\text{C}$	2	W	
	Collector Power Dissipation $T_c=25^\circ\text{C}$	50		
T_j	Junction Temperature	150	$^\circ\text{C}$	
T_{stg}	Storage Temperature Range	-65~150	$^\circ\text{C}$	

THERMAL CHARACTERISTICS

SYMBOL	PARAMETER	MAX	UNIT
$R_{th\ j-c}$	Thermal Resistance, Junction to Case	2.5	$^\circ\text{C}/\text{W}$
$R_{th\ j-a}$	Thermal Resistance, Junction to Ambient	62.5	$^\circ\text{C}/\text{W}$

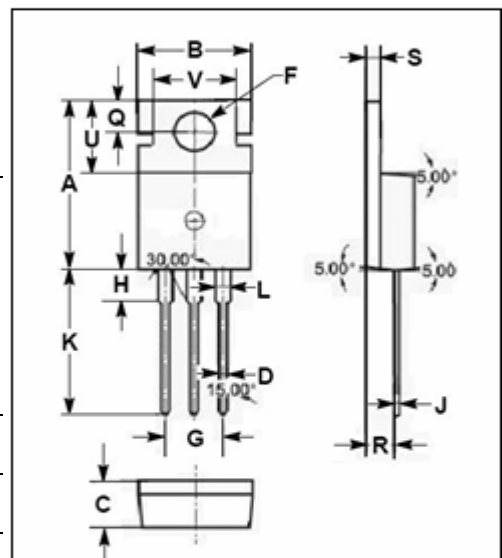
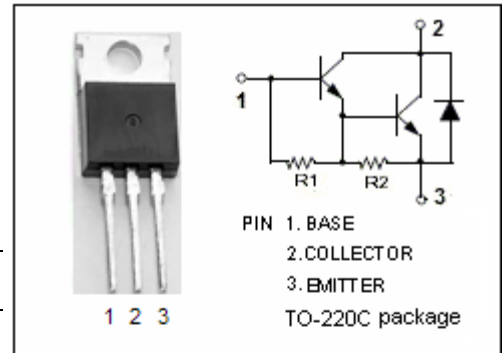

DIM	mm	
	MIN	MAX
A	15.70	15.90
B	9.90	10.10
C	4.20	4.40
D	0.70	0.90
F	3.40	3.60
G	4.98	5.18
H	2.70	2.90
J	0.44	0.46
K	13.20	13.40
L	1.10	1.30
Q	2.70	2.90
R	2.50	2.70
S	1.29	1.31
U	6.45	6.65
V	8.66	8.86

isc Silicon NPN Darlington Power Transistors

BDT61/A/B/C

ELECTRICAL CHARACTERISTICS

 $T_C=25^\circ\text{C}$ unless otherwise specified

SYMBOL	PARAMETER	CONDITIONS	MIN	TYP.	MAX	UNIT
$V_{(BR)CEO}$	Collector-Emitter Breakdown Voltage	BDT61	$I_C=30\text{mA}; I_B=0$			60
		BDT61A				80
		BDT61B				100
		BDT61C				120
$V_{CE(sat)}$	Collector-Emitter Saturation Voltage	$I_C=1.5\text{A}; I_B=6\text{mA}$			2.5	V
$V_{BE(on)}$	Base-Emitter On Voltage	$I_C=1.5\text{A}; V_{CE}=3\text{V}$			2.5	V
I_{CBO}	Collector Cutoff Current	BDT61				0.2 2.0
		BDT61A				0.2 2.0
		BDT61B				0.2 2.0
		BDT61C				0.2 2.0
I_{CEO}	Collector Cutoff Current	BDT61				0.5
		BDT61A				0.5
		BDT61B				0.5
		BDT61C				0.5
I_{EBO}	Emitter Cutoff Current	$V_{EB}=5\text{V}; I_C=0$			5	mA
h_{FE}	DC Current Gain	$I_C=1.5\text{A}; V_{CE}=3\text{V}$	750			
V_{ECF}	C-E Diode Forward Voltage	$I_E=1.5\text{A}$			2.0	V

Switching Times

t_{on}	Turn-On Time	$I_C=2\text{A}; I_{B1}=-I_{B2}=8\text{mA};$ $V_{BE(off)}=-5\text{V}; R_L=20\Omega$		1.0		μs
t_{off}	Turn-Off Time			4.5		μs