

# DWDM 80KM SFP+ TRANSCEIVER

TPD2XGKZRxxG



## Product Description

The TPD2XGKZRxxG is an enhanced small form factor pluggable (SFP+) fiber optic transceiver with digital diagnostics monitoring functionality (DDM). Supporting Ethernet and Fiber Channel standards with dense wavelength division multiplexing (DWDM) wavelength makes it ideally suited for high capacity data-com and storage area network applications. DDM functionality (alarm and warning features) is integrated into the design via an I<sup>2</sup>C serial interface per the Multi-Source Agreement (MSA) SFF-8472, Rev. 10.4.

Each transceiver utilizes an electro absorption modulator integrated laser (EML) with an operating wavelength at ITU 100GHz (0.8nm) grids offset by 50GHz. The transceiver supports data rates ranging from 11.3Gbps down to 8Gbps. It provides an excellent solution for data transmission at DWDM wavelength over up to 80km single mode fiber. The low power consumption and excellent EMI performance enable system design with high port density. The product is RoHS compliant and is designed and tested in accordance with industry safety standards. The transceiver is Class I Laser product per U.S. FDA/CDRH and international IEC-60825 standards.

The TPD2XGKZRxxG transceiver connects to standard 20-pad SFP+ connectors for hot plug capability. This allows the system designer to make configuration changes or maintenance by simply plugging in different transceivers without removing the power supply from the host system. The transmitter and receiver DATA interfaces are internally AC-coupled. LV-TTL Transmitter Disable control input and Loss of Signal (LOS) output interfaces are also provided.

The transceiver has bail-type latch, which offers an easy and convenient way to release the modules. The latch is compliant with the SFP MSA.

The transceiver operates from a single +3.3V power supply over an operating case temperature range of 5°C to +70°C (commercial), or -5°C to +85°C (extended) or -40°C to +85°C (industrial). The housing is made of metal for EMI immunity.

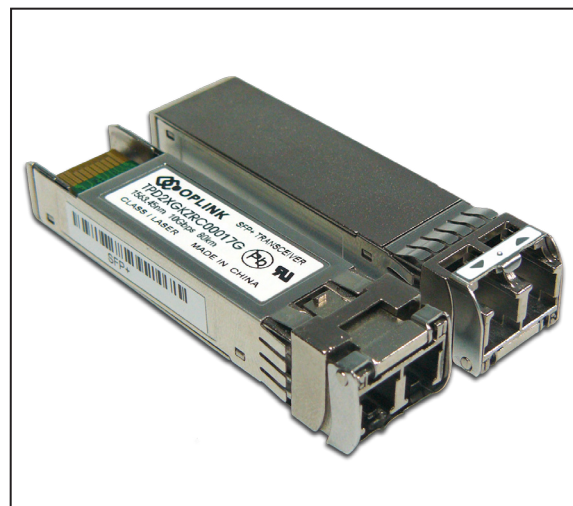

## Features

- ☑ Temperature-stabilized DWDM EML transmitter
- ☑ Transmission distance up to 80km (SM Fiber)
- ☑ Low power consumption
- ☑ Wide case operating temperature range
- ☑ Compliant to SFP+ Electrical MSA SFF-8431
- ☑ Compliant to SFP+ Mechanical MSA SFF-8432
- ☑ Digital Diagnostics Monitoring (DDM) through Serial Interface comply with SFF-8472, Rev. 10.4
- ☑ RoHS 6/6 compliant
- ☑ Laser Class 1 IEC/CDRH compliant

## Absolute Maximum Ratings

Parameter	Symbol	Minimum	Maximum	Units
Storage Temperature Range	$T_{ST}$	- 40	+ 85	°C
Operating Case Temperature <sup>1</sup>	"Commercial"	- 5	+ 70	°C
	"Extended"	- 5	+ 85	
	"Industrial"	- 40	+ 85	
Operating Relative Humidity <sup>2</sup>	$RH$	0	85	%
Supply Voltage Range	$V_{CC}$	- 0.5	+ 3.6	V

<sup>1</sup> Measured on top side of SFP+ module at the front center vent hole of the cage.

<sup>2</sup> Non condensing

**Transmitter Performance Characteristics** (Over Operating Case Temperature.  $V_{cc} = 3.13$  to  $3.47V$ )

Parameter	Symbol	Minimum	Typical	Maximum	Units
Data Rate	$B$	-	10.3125	-	Gb/s
Center Wavelength <sup>1</sup>	$\lambda_c$	See Ordering Information Table			nm
Average Optical Output Power	$P_{Avg}$	0	-	+ 5	dBm
Extinction Ratio	$ER$	8.2	-	-	dB
Relative Intensity Noise	$RIN$	-	-	- 128	dB/Hz
Side Mode Suppression Ratio	$SMSR$	30	-	-	dB
Optical Return Loss Tolerance	-	-	-	- 21	dB
Optical Output Eye	<i>Compliant with IEEE 802.3ae</i>				

<sup>1</sup> BOL : ±0.05nm from ITU grid; EOL: ±0.1nm from ITU grid.

**Receiver Performance Characteristics** (Over Operating Case Temperature.  $V_{cc} = 3.13$  to  $3.47V$ )

Parameter	Symbol	Minimum	Typical	Maximum	Units
Data Rate	$B$	-	10.3125	-	Gb/s
Wavelength of Operation	$\lambda$	1530	-	1565	nm
Receiver Sensitivity @ 10.3125Gb/s <sup>1</sup>	$P_{min\_BB}$	-	-	- 23	dBm
Receiver Sensitivity with 80km Fiber@10.3125Gb/s <sup>1</sup>	$P_{min\_Fiber}$	-	-	- 20	dBm
Maximum Input Optical Power ( $10^{-12}$ BER)	$P_{max}$	- 8	-	-	dBm
Receiver Reflectance	-	-	-	- 27	dB
LOS Hysteresis	-	0.5	-	-	dB
LOS Thresholds	Increasing Light Input	$P_{los+}$	-	- 25	dBm
	Decreasing Light Input	$P_{los-}$	- 38	-	

<sup>1</sup> Specified with BER <math>1 \times 10^{-12}</math> and PRBS 2<sup>31</sup>-1.

Note: The specified characteristics are met within the recommended range of operation. Unless otherwise noted typical data are quoted at nominal voltage and +25°C ambient temperature.

**Laser Safety:**

All transceivers are Class I Laser products per FDA/CDRH and IEC-60825 standards. They must be operated under specified operating conditions.



**Oplink Communications, Inc.**  
DATE OF MANUFACTURE:

This product complies with  
21 CFR 1040.10 and 1040.11  
**Meets Class I Laser Safety Requirements**

**Transmitter Electrical Characteristics** (Over Operating Case Temperature.  $V_{CC} = 3.13$  to  $3.47V$ )

Parameter	Symbol	Minimum	Typical	Maximum	Units
Differential Input Impedance	$Z_d$	-	100	-	$\Omega$
Differential Input Voltage Swing	$V_{PP-DIFF}$	180	-	700	mV
Input HIGH Voltage (TX Disable) <sup>1</sup>	$V_{IH}$	2.0	-	$V_{CC}$	V
Input LOW Voltage (TX Disable) <sup>1</sup>	$V_{IL}$	0	-	0.8	V
Output HIGH Voltage (TX Fault) <sup>2</sup>	$V_{OH}$	2.0	-	$V_{CC} + 0.3$	V
Output LOW Voltage (TX Fault) <sup>2</sup>	$V_{OL}$	0	-	0.8	V

<sup>1</sup> There is an internal 4.7k $\Omega$  to 10k $\Omega$  pull-up resistor to VccT.

<sup>2</sup> Open collector compatible, 4.7k $\Omega$  to 10k $\Omega$  pull-up resistor to Vcc (Host Supply Voltage).

**Receiver Electrical Interface** (Over Operating Case Temperature.  $V_{CC} = 3.13$  to  $3.47V$ )

Parameter	Symbol	Minimum	Typical	Maximum	Units
Differential Output Impedance	$Z_d$	-	100	-	$\Omega$
Differential Output Swing	$V_{PP-DIFF}$	300	-	850	mV
Output Rise and Fall time (20% to 80%)	$t_{RH}, t_{FH}$	28	-	-	ps
Output HIGH Voltage (LOS) <sup>1</sup>	$V_{OH}$	$V_{CC} - 1.3$	-	$V_{CC} + 0.3$	V
Output LOW Voltage (LOS) <sup>1</sup>	$V_{OL}$	0	-	0.8	V

<sup>1</sup> Open collector compatible, 4.7k $\Omega$  to 10k $\Omega$  pull-up resistor to Vcc (Host Supply Voltage).

**Electrical Power Supply Characteristics** (Over Operating Case Temperature.  $V_{CC} = 3.13$  to  $3.47V$ )

Parameter	Symbol	Minimum	Typical	Maximum	Units
Power Supply Voltage	$V_{CC}$	3.13	3.30	3.47	V
DC Common Mode Voltage	$V_{CM}$	0	-	3.60	V
Supply Current	$I_{VCC}$	-	365	-	mA
Power Consumption	C-temp	$P_W$	-	1.2	1.8
	E/I-temp				2.1

Note: The specified characteristics are met within the recommended range of operation. Unless otherwise noted typical data are quoted at nominal voltage and +25°C ambient temperature.

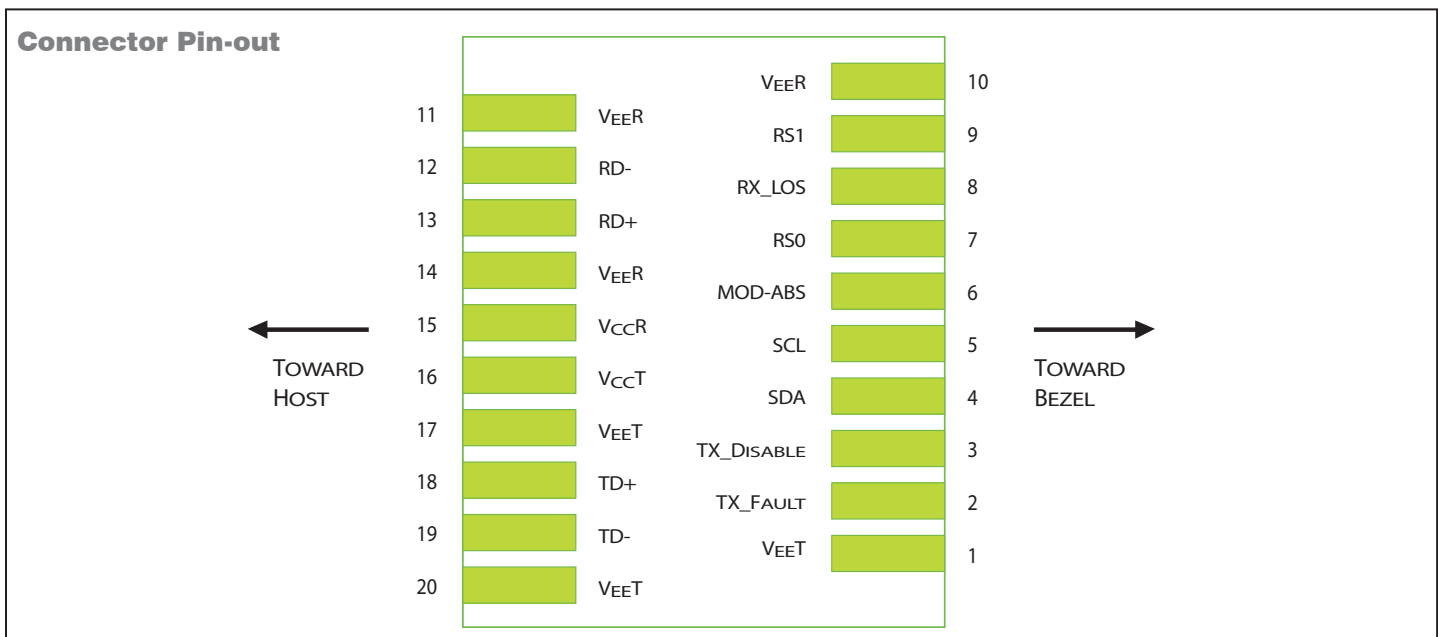

## Module Pin Description

Pin	Logic	Symbol	Description
1	-	<i>VeeT</i>	Module Transmitter Ground
2	<i>LVTTL-O</i>	<i>TX_Fault</i>	Module Transmitter Fault
3	<i>LVTTL-I</i>	<i>TX_Disable</i>	Transmitter Disable; Turns off transmitter laser output
4	<i>LVTTL-I/O</i>	<i>SDA</i>	2-Wire Serial Interface Data Line
5	<i>LVTTL-I/O</i>	<i>SCL</i>	2-Wire Serial Interface Clock
6	-	<i>MOD-ABS</i>	Module Definition, Grounded in the module
7	<i>LVTTL-I</i>	<i>RS0</i>	No function implemented
8	<i>LVTTL-O</i>	<i>RX_LOS</i>	Receiver Loss of Signal Indication
9	<i>LVTTL-I</i>	<i>RS1</i>	No function implemented
10	-	<i>VeeR</i>	Module Receiver Ground
11	-	<i>VeeR</i>	Module Receiver Ground
12	<i>CML-O</i>	<i>RD-</i>	Receiver Inverted Data Output
13	<i>CML-O</i>	<i>RD+</i>	Receiver Data Output
14	-	<i>VeeR</i>	Module Receiver Ground
15	-	<i>VccR</i>	Module Receiver 3.3V Supply
16	-	<i>VccT</i>	Module Transmitter 3.3V Supply
17	-	<i>VeeT</i>	Module Transmitter Ground
18	<i>CML-I</i>	<i>TD+</i>	Transmitter Non-Inverted Data Input
19	<i>CML-I</i>	<i>TD-</i>	Transmitter Inverted Data Input
20	-	<i>VeeT</i>	Module Transmitter Ground

## Application Notes

**Electrical Interface:** All signal interfaces are compliant with the SFP+ MSA specification. The high speed DATA interface is differential AC-coupled internally and can be directly connected to a 3.3V SERDES IC. All low speed control and sense output signals are open collector TTL compatible and should be pulled up with a 4.7kΩ - 10kΩ resistor on the host board.

**Loss of Signal (LOS):** The Loss of Signal circuit monitors the level of the incoming optical signal and generates logic HIGH when an insufficient photocurrent is produced.

**TX\_Fault:** The output indicates LOW when the transmitter is operating normally and HIGH with a laser fault including laser end-of-life. TX Fault is an open collector/drain output and should be pulled up with a 4.7kΩ - 10kΩ resistor on the host board.

**TX\_Disable:** When the TX Disable pin is at logic HIGH, the transmitter optical output is disabled. The laser is also disabled if this line is left floating, as it is pulled high inside the transceiver.

**Serial Identification and Monitoring:** The module definition of SFP is indicated by the MOD\_ABS pin and the

2-wire serial interface. Upon power up, the 2-wire interface appears as NC (no connection), and MOD\_ABS is TTL LOW. When the host system detects this condition, it activates the serial protocol (standard two-wire I<sup>2</sup>C serial interface) and generates the serial clock signal (SCL). The positive edge clocks data into the EEPROM segments of the device that are not write protected, and the negative edge clocks data from the device. The serial data signal (SDA) is for serial data transfer. The host uses SDA in conjunction with SCL to mark the start and end of serial protocol activation. The supported monitoring functions are temperature, voltage, bias current, transmitter power, average receiver signal, all alarms and warnings, and software monitoring of TX Fault/LOS. The device is internally calibrated.

The data transfer protocol and the details of the mandatory and vendor specific data structures are defined in the SFP MSA, and SFF-8472, Rev. 10.4.

**Power Supply and Grounding:** The power supply line should be well-filtered. All power supply bypass capacitors should be as close to the transceiver module as possible.

### Interfacing the Transceivers

Communication is via a serial 2-wire serial interface. As described in the document SFF-8472 (REV. 10.4) there are two distinct address spaces:

Base Address A0(hex)	
Byte Address	Content
0 – 95	Serial Transceiver ID as defined in SFP MSA
96 – 127	OPLINK Specific
128 – 255	Reserved

Base Address A2(hex)	
Byte Address	Content
0 - 55	Alarm & Warnings thresholds & limits
56 - 95	External calibration constants (not used)
96 – 119	Values from real time diagnostic monitoring
120 – 127	Not used
128 – 247	Customer specific, writable area
248 - 255	Not used

### Application Schematics Recommended electrical connections to transceiver are shown below.

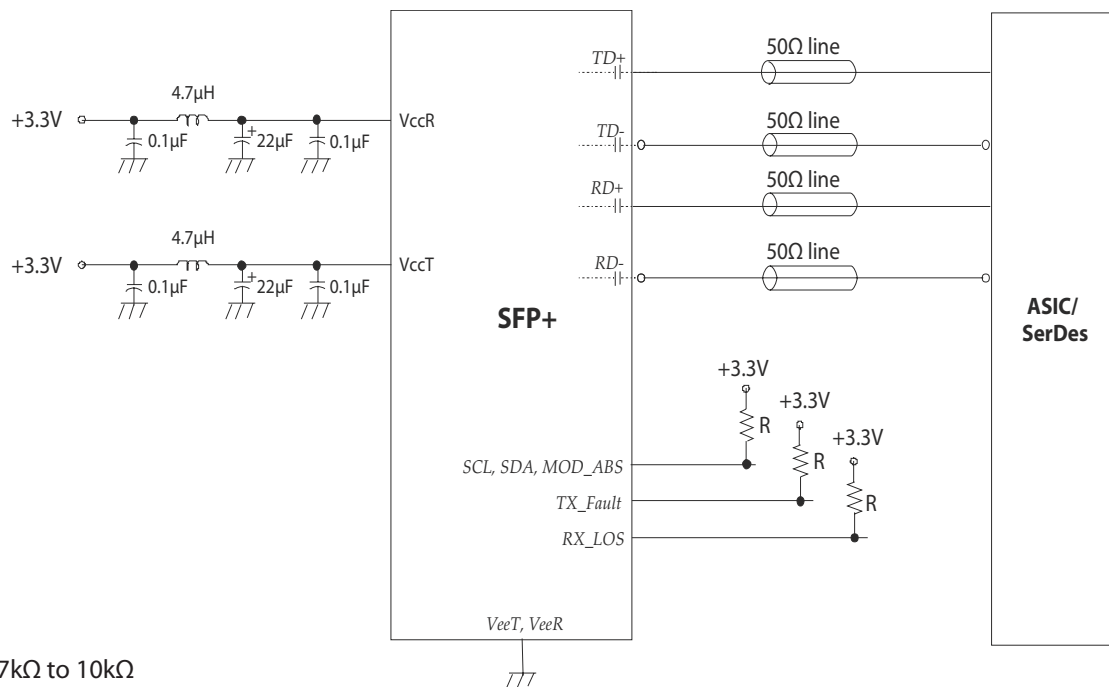

### ESD & Electromagnetic Compatibility

Requirements	Standard	Status
Electro Static Discharge to the Electrical Pins (ESD)	EIA/JESD22-A114-B MIL-STD 883C Method 3015.7	Exceeds requirements Class 1B (>1000V)
Immunity to ESD (housing, receptacle)	IEN 61000-4-2	Exceeds requirements Discharges ranging from 2kV to 15kV without damages to the transceiver
Electromagnetic Emission (EMI)	FCC Part 15, Class B EN 55022 Class B CISPR 22	Exceeds requirements Class B

**Package Outline**

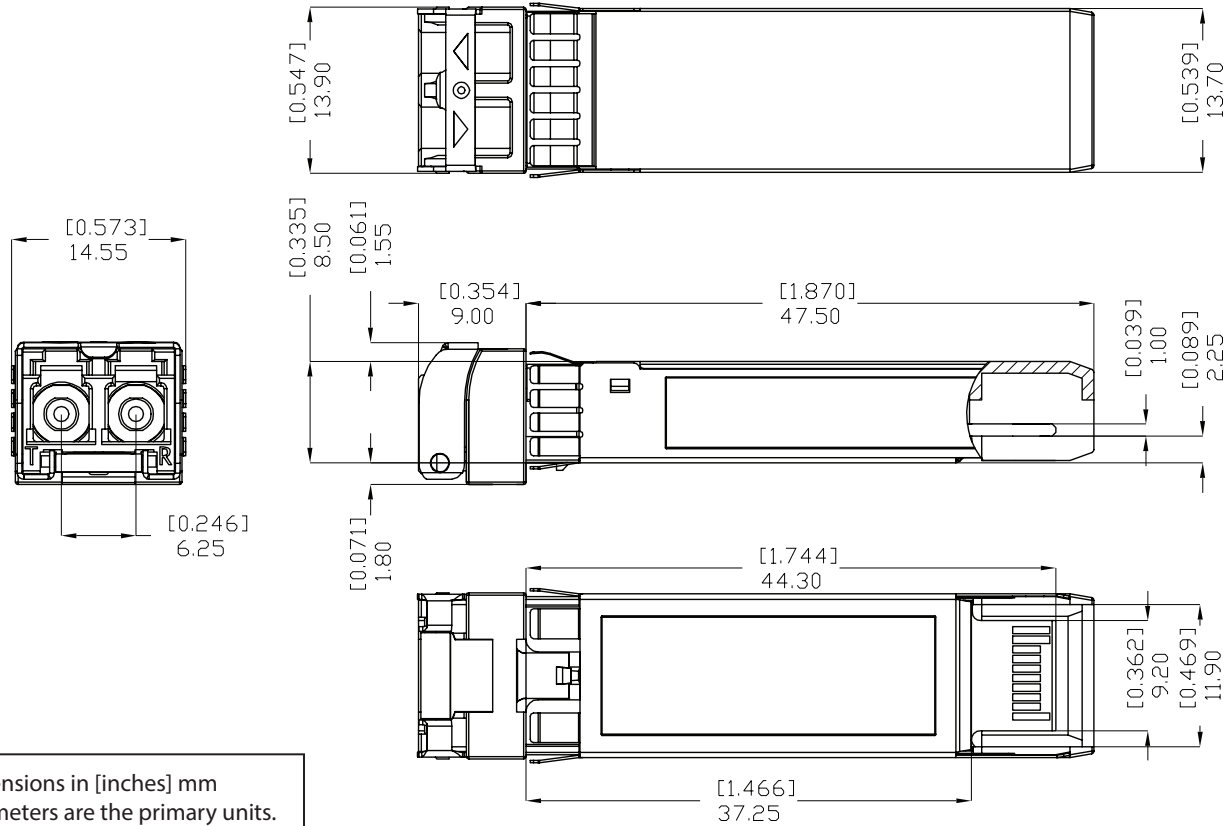

Dimensions in [inches] mm  
 Millimeters are the primary units.  
 Tolerances are in accordance with  
 SFF-8432 Rev.5

**Ordering Information**

Oplink can provide a remarkable range of customized optical solutions. For detail, please contact Oplink's Sales and Marketing for your requirements and ordering information (510) 933-7200 or Sales@oplink.com.

Model Name	Operating Temperature		Center Wavelength (nm)	ITU Frequency (THz)	Wavelength Reference	Distance
TPD2XGKZRC00061G	- 5°C to +70°C	Commercial	1528.38	196.15	H61	80km
TPD2XGKZRC00060G	- 5°C to +70°C	Commercial	1529.16	196.05	H60	80km
TPD2XGKZRC00059G	- 5°C to +70°C	Commercial	1529.94	195.95	H59	80km
TPD2XGKZRC00058G	- 5°C to +70°C	Commercial	1530.72	195.85	H58	80km
TPD2XGKZRC00057G	- 5°C to +70°C	Commercial	1531.51	195.75	H57	80km
TPD2XGKZRC00056G	- 5°C to +70°C	Commercial	1532.29	195.65	H56	80km
TPD2XGKZRC00055G	- 5°C to +70°C	Commercial	1533.07	195.55	H55	80km
TPD2XGKZRC00054G	- 5°C to +70°C	Commercial	1533.86	195.45	H54	80km
TPD2XGKZRC00053G	- 5°C to +70°C	Commercial	1534.64	195.35	H53	80km
TPD2XGKZRC00052G	- 5°C to +70°C	Commercial	1535.43	195.25	H52	80km
TPD2XGKZRC00051G	- 5°C to +70°C	Commercial	1536.22	195.15	H51	80km
TPD2XGKZRC00050G	- 5°C to +70°C	Commercial	1537.00	195.05	H50	80km
TPD2XGKZRC00049G	- 5°C to +70°C	Commercial	1537.79	194.95	H49	80km
TPD2XGKZRC00048G	- 5°C to +70°C	Commercial	1538.58	194.85	H48	80km
TPD2XGKZRC00047G	- 5°C to +70°C	Commercial	1539.37	194.75	H47	80km
TPD2XGKZRC00046G	- 5°C to +70°C	Commercial	1540.16	194.65	H46	80km

Model Name	Operating Temperature		Center Wavelength (nm)	ITU Frequency (THz)	Wavelength Reference	Distance
TPD2XGKZRC00045G	- 5°C to +70°C	Commercial	1540.95	194.55	H45	80km
TPD2XGKZRC00044G	- 5°C to +70°C	Commercial	1541.75	194.45	H44	80km
TPD2XGKZRC00043G	- 5°C to +70°C	Commercial	1542.54	194.35	H43	80km
TPD2XGKZRC00042G	- 5°C to +70°C	Commercial	1543.33	194.25	H42	80km
TPD2XGKZRC00041G	- 5°C to +70°C	Commercial	1544.13	194.15	H41	80km
TPD2XGKZRC00040G	- 5°C to +70°C	Commercial	1544.92	194.05	H40	80km
TPD2XGKZRC00039G	- 5°C to +70°C	Commercial	1545.72	193.95	H39	80km
TPD2XGKZRC00038G	- 5°C to +70°C	Commercial	1546.52	193.85	H38	80km
TPD2XGKZRC00037G	- 5°C to +70°C	Commercial	1547.32	193.75	H37	80km
TPD2XGKZRC00036G	- 5°C to +70°C	Commercial	1548.11	193.65	H36	80km
TPD2XGKZRC00035G	- 5°C to +70°C	Commercial	1548.91	193.55	H35	80km
TPD2XGKZRC00034G	- 5°C to +70°C	Commercial	1549.72	193.45	H34	80km
TPD2XGKZRC00033G	- 5°C to +70°C	Commercial	1550.52	193.35	H33	80km
TPD2XGKZRC00032G	- 5°C to +70°C	Commercial	1551.32	193.25	H32	80km
TPD2XGKZRC00031G	- 5°C to +70°C	Commercial	1552.12	193.15	H31	80km
TPD2XGKZRC00030G	- 5°C to +70°C	Commercial	1552.93	193.05	H30	80km
TPD2XGKZRC00029G	- 5°C to +70°C	Commercial	1553.73	192.95	H29	80km
TPD2XGKZRC00028G	- 5°C to +70°C	Commercial	1554.54	192.85	H28	80km
TPD2XGKZRC00027G	- 5°C to +70°C	Commercial	1555.34	192.75	H27	80km
TPD2XGKZRC00026G	- 5°C to +70°C	Commercial	1556.15	192.65	H26	80km
TPD2XGKZRC00025G	- 5°C to +70°C	Commercial	1556.96	192.55	H25	80km
TPD2XGKZRC00024G	- 5°C to +70°C	Commercial	1557.77	192.45	H24	80km
TPD2XGKZRC00023G	- 5°C to +70°C	Commercial	1558.58	192.35	H23	80km
TPD2XGKZRC00022G	- 5°C to +70°C	Commercial	1559.39	192.25	H22	80km
TPD2XGKZRC00021G	- 5°C to +70°C	Commercial	1560.20	192.15	H21	80km
TPD2XGKZRC00020G	- 5°C to +70°C	Commercial	1561.01	192.05	H20	80km
TPD2XGKZRC00019G	- 5°C to +70°C	Commercial	1561.83	191.95	H19	80km
TPD2XGKZRC00018G	- 5°C to +70°C	Commercial	1562.64	191.85	H18	80km
TPD2XGKZRC00017G	- 5°C to +70°C	Commercial	1563.45	191.75	H17	80km
TPD2XGKZRC00016G	- 5°C to +70°C	Commercial	1564.27	191.65	H16	80km

Model Name	Operating Temperature		Center Wavelength (nm)	ITU Frequency (THz)	Wavelength Reference	Distance
TPD2XGKZRE00061G	- 5°C to +85°C	Extended	1528.38	196.15	H61	80km
TPD2XGKZRE00060G	- 5°C to +85°C	Extended	1529.16	196.05	H60	80km
TPD2XGKZRE00059G	- 5°C to +85°C	Extended	1529.94	195.95	H59	80km
TPD2XGKZRE00058G	- 5°C to +85°C	Extended	1530.72	195.85	H58	80km
TPD2XGKZRE00057G	- 5°C to +85°C	Extended	1531.51	195.75	H57	80km
TPD2XGKZRE00056G	- 5°C to +85°C	Extended	1532.29	195.65	H56	80km
TPD2XGKZRE00055G	- 5°C to +85°C	Extended	1533.07	195.55	H55	80km
TPD2XGKZRE00054G	- 5°C to +85°C	Extended	1533.86	195.45	H54	80km
TPD2XGKZRE00053G	- 5°C to +85°C	Extended	1534.64	195.35	H53	80km
TPD2XGKZRE00052G	- 5°C to +85°C	Extended	1535.43	195.25	H52	80km
TPD2XGKZRE00051G	- 5°C to +85°C	Extended	1536.22	195.15	H51	80km

Model Name	Operating Temperature		Center Wavelength (nm)	ITU Frequency (THz)	Wavelength Reference	Distance
TPD2XGKZRE00050G	- 5°C to +85°C	Extended	1537.00	195.05	H50	80km
TPD2XGKZRE00049G	- 5°C to +85°C	Extended	1537.79	194.95	H49	80km
TPD2XGKZRE00048G	- 5°C to +85°C	Extended	1538.58	194.85	H48	80km
TPD2XGKZRE00047G	- 5°C to +85°C	Extended	1539.37	194.75	H47	80km
TPD2XGKZRE00046G	- 5°C to +85°C	Extended	1540.16	194.65	H46	80km
TPD2XGKZRE00045G	- 5°C to +85°C	Extended	1540.95	194.55	H45	80km
TPD2XGKZRE00044G	- 5°C to +85°C	Extended	1541.75	194.45	H44	80km
TPD2XGKZRE00043G	- 5°C to +85°C	Extended	1542.54	194.35	H43	80km
TPD2XGKZRE00042G	- 5°C to +85°C	Extended	1543.33	194.25	H42	80km
TPD2XGKZRE00041G	- 5°C to +85°C	Extended	1544.13	194.15	H41	80km
TPD2XGKZRE00040G	- 5°C to +85°C	Extended	1544.92	194.05	H40	80km
TPD2XGKZRE00039G	- 5°C to +85°C	Extended	1545.72	193.95	H39	80km
TPD2XGKZRE00038G	- 5°C to +85°C	Extended	1546.52	193.85	H38	80km
TPD2XGKZRE00037G	- 5°C to +85°C	Extended	1547.32	193.75	H37	80km
TPD2XGKZRE00036G	- 5°C to +85°C	Extended	1548.11	193.65	H36	80km
TPD2XGKZRE00035G	- 5°C to +85°C	Extended	1548.91	193.55	H35	80km
TPD2XGKZRE00034G	- 5°C to +85°C	Extended	1549.72	193.45	H34	80km
TPD2XGKZRE00033G	- 5°C to +85°C	Extended	1550.52	193.35	H33	80km
TPD2XGKZRE00032G	- 5°C to +85°C	Extended	1551.32	193.25	H32	80km
TPD2XGKZRE00031G	- 5°C to +85°C	Extended	1552.12	193.15	H31	80km
TPD2XGKZRE00030G	- 5°C to +85°C	Extended	1552.93	193.05	H30	80km
TPD2XGKZRE00029G	- 5°C to +85°C	Extended	1553.73	192.95	H29	80km
TPD2XGKZRE00028G	- 5°C to +85°C	Extended	1554.54	192.85	H28	80km
TPD2XGKZRE00027G	- 5°C to +85°C	Extended	1555.34	192.75	H27	80km
TPD2XGKZRE00026G	- 5°C to +85°C	Extended	1556.15	192.65	H26	80km
TPD2XGKZRE00025G	- 5°C to +85°C	Extended	1556.96	192.55	H25	80km
TPD2XGKZRE00024G	- 5°C to +85°C	Extended	1557.77	192.45	H24	80km
TPD2XGKZRE00023G	- 5°C to +85°C	Extended	1558.58	192.35	H23	80km
TPD2XGKZRE00022G	- 5°C to +85°C	Extended	1559.39	192.25	H22	80km
TPD2XGKZRE00021G	- 5°C to +85°C	Extended	1560.20	192.15	H21	80km
TPD2XGKZRE00020G	- 5°C to +85°C	Extended	1561.01	192.05	H20	80km
TPD2XGKZRE00019G	- 5°C to +85°C	Extended	1561.83	191.95	H19	80km
TPD2XGKZRE00018G	- 5°C to +85°C	Extended	1562.64	191.85	H18	80km
TPD2XGKZRE00017G	- 5°C to +85°C	Extended	1563.45	191.75	H17	80km
TPD2XGKZRE00016G	- 5°C to +85°C	Extended	1564.27	191.65	H16	80km

Model Name	Operating Temperature		Center Wavelength (nm)	ITU Frequency (THz)	Wavelength Reference	Distance
TPD2XGKZRI00061G	- 40°C to +85°C	Industrial	1528.38	196.15	H61	80km
TPD2XGKZRI00060G	- 40°C to +85°C	Industrial	1529.16	196.05	H60	80km
TPD2XGKZRI00059G	- 40°C to +85°C	Industrial	1529.94	195.95	H59	80km
TPD2XGKZRI00058G	- 40°C to +85°C	Industrial	1530.72	195.85	H58	80km
TPD2XGKZRI00057G	- 40°C to +85°C	Industrial	1531.51	195.75	H57	80km
TPD2XGKZRI00056G	- 40°C to +85°C	Industrial	1532.29	195.65	H56	80km

Model Name	Operating Temperature		Center Wavelength (nm)	ITU Frequency (THz)	Wavelength Reference	Distance
TPD2XGKZRI00055G	- 40°C to +85°C	Industrial	1533.07	195.55	H55	80km
TPD2XGKZRI00054G	- 40°C to +85°C	Industrial	1533.86	195.45	H54	80km
TPD2XGKZRI00053G	- 40°C to +85°C	Industrial	1534.64	195.35	H53	80km
TPD2XGKZRI00052G	- 40°C to +85°C	Industrial	1535.43	195.25	H52	80km
TPD2XGKZRI00051G	- 40°C to +85°C	Industrial	1536.22	195.15	H51	80km
TPD2XGKZRI00050G	- 40°C to +85°C	Industrial	1537.00	195.05	H50	80km
TPD2XGKZRI00049G	- 40°C to +85°C	Industrial	1537.79	194.95	H49	80km
TPD2XGKZRI00048G	- 40°C to +85°C	Industrial	1538.58	194.85	H48	80km
TPD2XGKZRI00047G	- 40°C to +85°C	Industrial	1539.37	194.75	H47	80km
TPD2XGKZRI00046G	- 40°C to +85°C	Industrial	1540.16	194.65	H46	80km
TPD2XGKZRI00045G	- 40°C to +85°C	Industrial	1540.95	194.55	H45	80km
TPD2XGKZRI00044G	- 40°C to +85°C	Industrial	1541.75	194.45	H44	80km
TPD2XGKZRI00043G	- 40°C to +85°C	Industrial	1542.54	194.35	H43	80km
TPD2XGKZRI00042G	- 40°C to +85°C	Industrial	1543.33	194.25	H42	80km
TPD2XGKZRI00041G	- 40°C to +85°C	Industrial	1544.13	194.15	H41	80km
TPD2XGKZRI00040G	- 40°C to +85°C	Industrial	1544.92	194.05	H40	80km
TPD2XGKZRI00039G	- 40°C to +85°C	Industrial	1545.72	193.95	H39	80km
TPD2XGKZRI00038G	- 40°C to +85°C	Industrial	1546.52	193.85	H38	80km
TPD2XGKZRI00037G	- 40°C to +85°C	Industrial	1547.32	193.75	H37	80km
TPD2XGKZRI00036G	- 40°C to +85°C	Industrial	1548.11	193.65	H36	80km
TPD2XGKZRI00035G	- 40°C to +85°C	Industrial	1548.91	193.55	H35	80km
TPD2XGKZRI00034G	- 40°C to +85°C	Industrial	1549.72	193.45	H34	80km
TPD2XGKZRI00033G	- 40°C to +85°C	Industrial	1550.52	193.35	H33	80km
TPD2XGKZRI00032G	- 40°C to +85°C	Industrial	1551.32	193.25	H32	80km
TPD2XGKZRI00031G	- 40°C to +85°C	Industrial	1552.12	193.15	H31	80km
TPD2XGKZRI00030G	- 40°C to +85°C	Industrial	1552.93	193.05	H30	80km
TPD2XGKZRI00029G	- 40°C to +85°C	Industrial	1553.73	192.95	H29	80km
TPD2XGKZRI00028G	- 40°C to +85°C	Industrial	1554.54	192.85	H28	80km
TPD2XGKZRI00027G	- 40°C to +85°C	Industrial	1555.34	192.75	H27	80km
TPD2XGKZRI00026G	- 40°C to +85°C	Industrial	1556.15	192.65	H26	80km
TPD2XGKZRI00025G	- 40°C to +85°C	Industrial	1556.96	192.55	H25	80km
TPD2XGKZRI00024G	- 40°C to +85°C	Industrial	1557.77	192.45	H24	80km
TPD2XGKZRI00023G	- 40°C to +85°C	Industrial	1558.58	192.35	H23	80km
TPD2XGKZRI00022G	- 40°C to +85°C	Industrial	1559.39	192.25	H22	80km
TPD2XGKZRI00021G	- 40°C to +85°C	Industrial	1560.20	192.15	H21	80km
TPD2XGKZRI00020G	- 40°C to +85°C	Industrial	1561.01	192.05	H20	80km
TPD2XGKZRI00019G	- 40°C to +85°C	Industrial	1561.83	191.95	H19	80km
TPD2XGKZRI00018G	- 40°C to +85°C	Industrial	1562.64	191.85	H18	80km
TPD2XGKZRI00017G	- 40°C to +85°C	Industrial	1563.45	191.75	H17	80km
TPD2XGKZRI00016G	- 40°C to +85°C	Industrial	1564.27	191.65	H16	80km

Oplink Communications, Inc. reserves the right to make changes in equipment design or specifications without notice. Information supplied by Oplink Communications, Inc. is believed to be accurate and reliable. However, no responsibility is assumed by Oplink Communications, Inc. for its use nor for any infringements of third parties, which may result from its use. No license is granted by implication or otherwise under any patent right of Oplink Communications, Inc.