

**Order Number  
203702-4300**

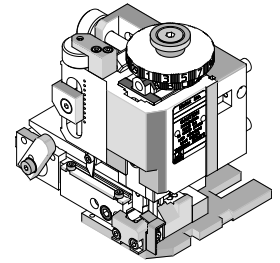

**Application Tooling Specification**

**FEATURES**

- Quick punch removal with the push of a button for fast and easy tooling change
- Applicator designed to industry-standard mounting and 135.80mm (5.346") shut height
- Quick setup time; plus, the crimp height, track and feed adjustments can be set without removing the applicator from the press
- Fine adjustment allows users to achieve target with little effort by adjusting in increments of 0.015mm (.0006") for conductor crimp height and 0.063mm (.0025") for insulation height
- Independent adjustment rings allow users to quickly adjust the conductor or insulation crimp height without affecting each other
- This tool is IPC/WHMA-A-620 Class 2 Compliant, as indicated below
- Directly adapts to most automatic wire processing machines
- For 20-22 AWG terminals, use FineAdjust applicator 203702-4400

**SCOPE**

**Products:** Ultra-Fit Tang-less Plug Crimp Terminals, 16-18 AWG (UL1061) wire.

Terminal Series No.	Terminal Order No.	Wire Size		Insulation Diameter				Strip Length	
				IPC/WHMA-A-620 (1)		Terminal (2)			
		AWG	Wire Type	mm	In.	mm	In.	mm	In.
216946	216946-5011 216946-5012 216946-5013	16-18	UL1061	1.75-2.05	.069-.081	1.70-2.00	.067-.079	3.5-4.0	.14-.16
<p><b>(1)</b> To achieve optimum IPC/WHMA-A-620 class 2 insulation crimps, use this insulation OD range.  <b>(2)</b> Overall insulation OD specification for terminal.</p>									

**DEFINITION OF TERMS**

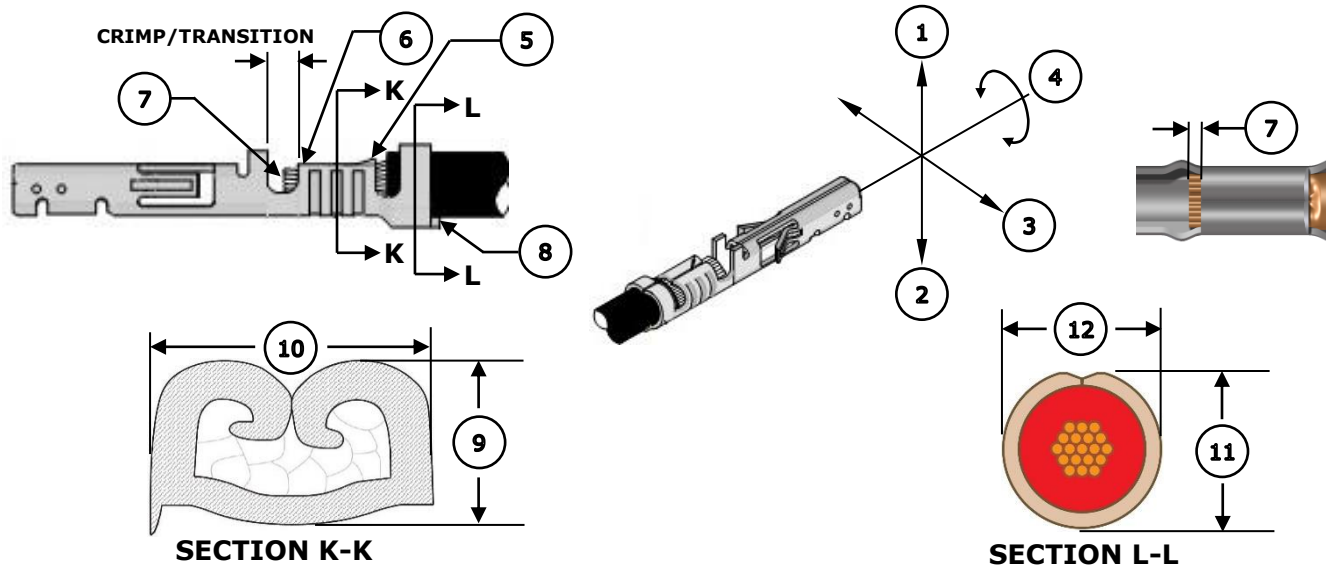

Note: Image above is a generic terminal representation. The actual terminals of the scope may look different.

**CRIMP SPECIFICATION**

Feature	Requirement					
<b>1. Bend Up</b>	3° Max					
<b>2. Bend Down</b>	3° Max					
<b>3. Twist</b>	3° Max					
<b>4. Roll</b>	5° Max					
<b>5. Bell Mouth Rear</b>	0.30-0.80mm (.012-.031")					
<b>6. Bell Mouth Front</b>	Not Applicable					
<b>7. Conductor Brush</b>	0.00-1.00mm (.000-.039")					
<b>8. Cut-Off Tab</b>	0.20mm (.008") Max					
<b>Conductor Crimp</b>	<b>Terminal Order No.</b>	<b>Wire Size</b>	<b>9. Crimp Height</b>		<b>10. Crimp Width (Ref)</b>	
	216946-5011 216946-5012 216946-5013	16 AWG	1.18-1.28mm	.046-.050 In.	1.95-2.05mm	.077-.081 In.
		18 AWG	0.95-1.05mm	.037-.041 In.	1.95-2.05mm	.077-.081 In.
<b>Insulation Crimp</b>	<b>Terminal Order No.</b>	<b>Wire Size</b>	<b>11. Crimp Height (Ref)</b>		<b>12. Crimp Width (Ref)</b>	
	216946-5011 216946-5012 216946-5013	16 AWG	2.13mm	.084 In.	2.45mm	.096 In.
		18 AWG	1.98mm	.078 In.	2.40mm	.094 In.
<b>Pull Force</b>	<b>Terminal Order No.</b>	<b>Wire Size</b>	<b>Minimum Pull Force</b>		To be measured with no influence from the insulation crimp.	
	216946-5011 216946-5012 216946-5013	16 AWG	68.4 N	15.3 lb.		
		18 AWG	68.4 N	15.3 lb.		

**Tool Qualification Notes**

1. Pull force should be measured with no influence from the insulation crimp.
2. The above specifications are guidelines to an optimum crimp.
3. Terminal oiler (63801-7240) required to improve tooling life and minimize the crimp sticking in the punches. See 63800-4900 FineAdjust manual.

**PARTS LIST**

<b>FineAdjust Applicator 203702-4300</b>				
<b>Item</b>	<b>Order No.</b>	<b>Engineering No.</b>	<b>Description</b>	<b>Quantity</b>
<b>Perishable Tooling</b>				
	203702-4370	203702-4370	Tool Kit (All "Y" Items)	REF
1	200216-2002	200216-2002	Conductor Punch	1 Y
2	63455-2001	63455-2001	Conductor Anvil	1 Y
3	63454-2404	63454-2404	Insulation Punch	1 Y
4	63445-2411	63445-2411	Insulation Anvil	1 Y
5	63443-0002	63443-0002	Cut-Off Plunger	1 Y
6	63443-0012	63443-0012	Front Plunger Retainer	1 Y
<b>Other Components</b>				
7	11-17-0022	1739-21	Compression Spring	1
8	11-18-4083	60707-8	Feed Guide	1
9	11-24-1067	4996-4	Cut-Off Plunger Spring	1
10	63443-0009	63443-0009	Front Scrap Chute	1
11	63443-0024	63443-0024	Key	1
12	63443-0090	63443-0090	Wire Stop	1
13	63443-0093	63443-0093	Shank	1
14	200213-7511	200213-7511	Anvil Mount	1
15	63443-2802	63443-2802	Front Plunger Striker	1
16	63443-2911	63443-2911	Wire Hold Down Plunger	1
17	63443-7101	63443-7101	Terminal Hold Down	1
18	63443-6115	63443-6115	Rear Cover	1
19	63600-0021	63600-0021	Compression Spring	1
<b>Frame</b>				
20	63800-4901	63800-4901	Top	1
21	63801-3281	63801-3281	Base	1
22	63801-4650	63801-4650	Track	1
<b>Hardware</b>				
23	—	—	M3 by 6 Long SHCS	2*
24	—	—	M3 by 6 Long FHCS	1*
25	—	—	M3 by 8 Long SHCS	1*
26	—	—	M4 by 6 Long SHCS	2*
27	—	—	M4 by 12 Long BHCS	2*
28	—	—	M4 by 50 Long SHCS	2*
29	—	—	M5 by 12 Long SHCS	1*
30	—	—	M5 by 10 Long Flat Point SSS	1*
31	—	—	M5 Hex Jam Nut	1*
* Available from an industrial supply company.				

**ASSEMBLY DRAWING**

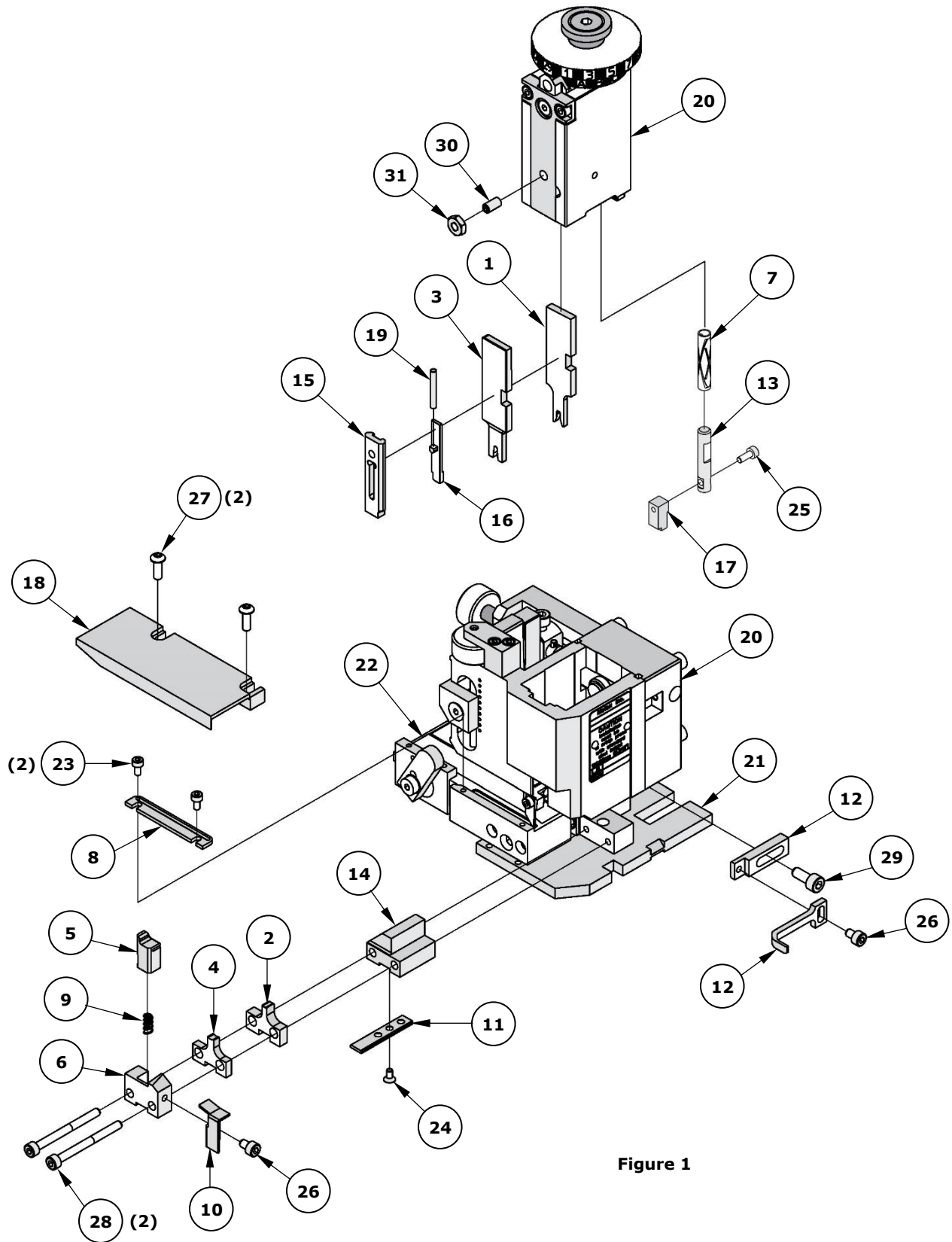

Figure 1

## NOTES

---

1. Molex recommends that an extra perishable tooling kit be maintained at your facility.
2. Verify tooling alignment by manually cycling the press and applicator before crimping under power. Check that all screws are tight.
3. Slugs, terminals, dirt and oil should be kept clear of the work area.
4. Wear safety glasses at all times.
5. For recommended maintenance, refer to the FineAdjust manual.

**CAUTION:** This applicator should only be used in a press with a shut height of 135.8mm (5.346"). Tooling damage could result at a lower setting.

**CAUTION:** To prevent injury, never operate this applicator without the guards supplied with the press or wire-processing machine in place. Reference the press or wire processing manufacturer's instruction manual.

**CAUTION:** Molex crimp specifications are valid only when used with Molex terminals, applicators and tooling.

### Application Tooling Support

**Phone:** (402) 458-TOOL (8665)

**E-Mail:** [toolingsupport@molex.com](mailto:toolingsupport@molex.com)

**Website:** [www.molex.com/applicationtooling](http://www.molex.com/applicationtooling)

Molex is a registered trademark of Molex, LLC in the United States of America and may be registered in other countries; all other trademarks listed herein belong to their respective owners.