

1. PART NO. EXPRESSION :

SSC05024R1YZF-□□
 (a) (b) (c) (d)(e)(f) (g)

- (a) Series code
- (b) Dimension code
- (c) Inductance code : 4R1 = 4.10uH
- (d) Tolerance code : Y = ±30%
- (e) X, Y, Z : Standard part
- (f) F : RoHS Compliant
- (g) 11 ~ 99 : Internal controlled number

2. CONFIGURATION & DIMENSIONS :

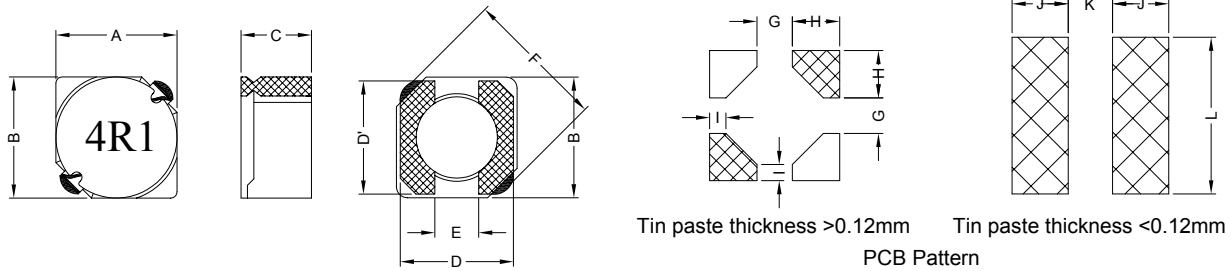

Unit : m/m

A	B	C	D	D'	E	F
5.70±0.3	5.70±0.3	2.00 Max.	5.50 Ref.	5.50 Ref.	2.00 Ref.	8.20 Max.
G	H	I	J	K	L	
2.20 Ref.	2.05 Ref.	0.85 Ref.	2.15 Ref.	2.00 Ref.	6.30 Ref.	

3. SCHEMATIC :

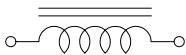

4. MATERIALS :

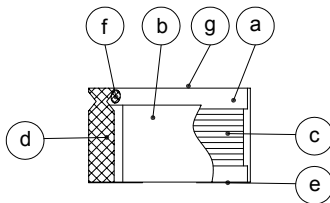

- (a) Core : DR Ferrite Core
- (b) Core : RI Ferrite Core
- (c) Wire : Enamelled Copper Wire
- (d) Terminal : Au+Ni Copper Plate
- (e) Adhesive : Epoxy
- (f) Adhesive : Epoxy
- (g) Ink : Bon Margue



RoHS Compliant

NOTE : Specifications subject to change without notice. Please check our website for latest information.

01.10.2010

5. GENERAL SPECIFICATION :

- a) Temp. rise : 40°C Max. at rated current
- b) Rated current : Base on temp. rise & $\Delta L/L0A = 35\%$ Max.
- c) Storage temp. : -40°C to +125°C
- d) Operating temp. : -40°C to +95°C
- e) Resistance to solder heat : 260°C.10 secs

6. ELECTRICAL CHARACTERISTICS :

Part No.	Inductance (μ H)	Test Frequency (Hz)	RDC (m Ω) Max.	IDC (A) Max.
SSC05024R1YZF-□□	4.1 \pm 30%	0.5V / 10K	57	1.95
SSC05025R4YZF-□□	5.4 \pm 30%	0.5V / 10K	76	1.60
SSC05026R2YZF-□□	6.2 \pm 30%	0.5V / 10K	96	1.40
SSC05028R9YZF-□□	8.9 \pm 30%	0.5V / 10K	116	1.25
SSC0502100YZF-□□	10.0 \pm 30%	0.5V / 10K	124	1.20
SSC0502120YZF-□□	12.0 \pm 30%	0.5V / 10K	153	1.10
SSC0502150YZF-□□	15.0 \pm 30%	0.5V / 10K	196	0.97
SSC0502180YZF-□□	18.0 \pm 30%	0.5V / 10K	210	0.85
SSC0502220YZF-□□	22.0 \pm 30%	0.5V / 10K	290	0.80
SSC0502270YZF-□□	27.0 \pm 30%	0.5V / 10K	330	0.75
SSC0502330YZF-□□	33.0 \pm 30%	0.5V / 10K	385	0.65
SSC0502390YZF-□□	39.0 \pm 30%	0.5V / 10K	520	0.57
SSC0502470YZF-□□	47.0 \pm 30%	0.5V / 10K	595	0.54
SSC0502560YZF-□□	56.0 \pm 30%	0.5V / 10K	665	0.50
SSC0502680YZF-□□	68.0 \pm 30%	0.5V / 10K	840	0.43
SSC0502820YZF-□□	82.0 \pm 30%	0.5V / 10K	978	0.41
SSC0502101YZF-□□	100.0 \pm 30%	0.5V / 10K	1200	0.36



RoHS Compliant

NOTE : Specifications subject to change without notice. Please check our website for latest information.

01.10.2010



SUPERWORLD ELECTRONICS (S) PTE LTD

PG. 2

7. CHARACTERISTICS CURVES :

@ TEMP. RISE VS. DC SUPERPOSITION RESPONSE CURVE

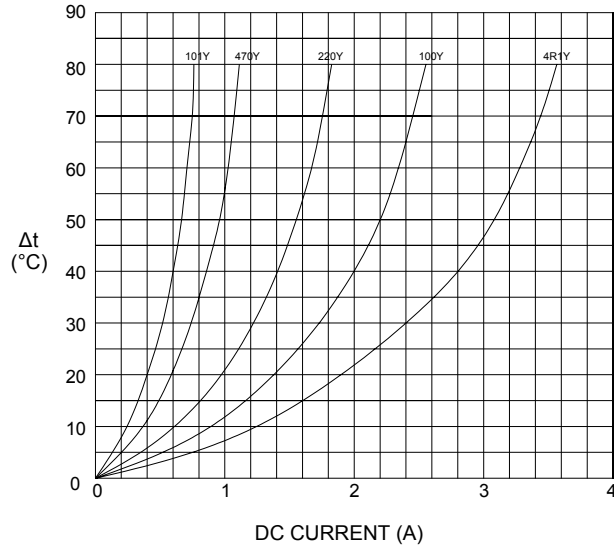

@ INDUCTANCE VS. FREQUENCY RESPONSE CURVE

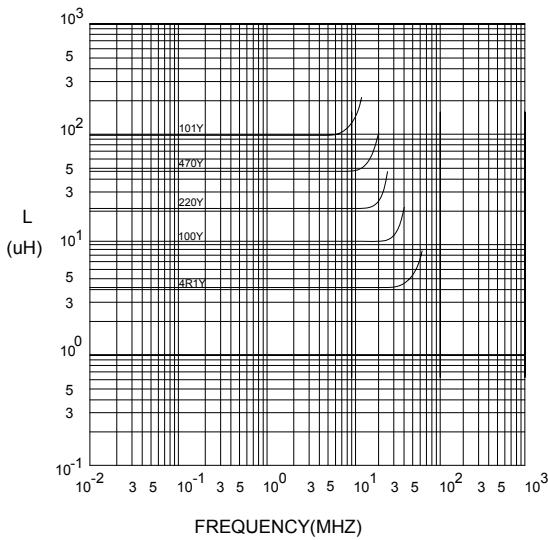

@ INDUCTANCE VS. DC SUPERPOSITION RESPONSE CURVE

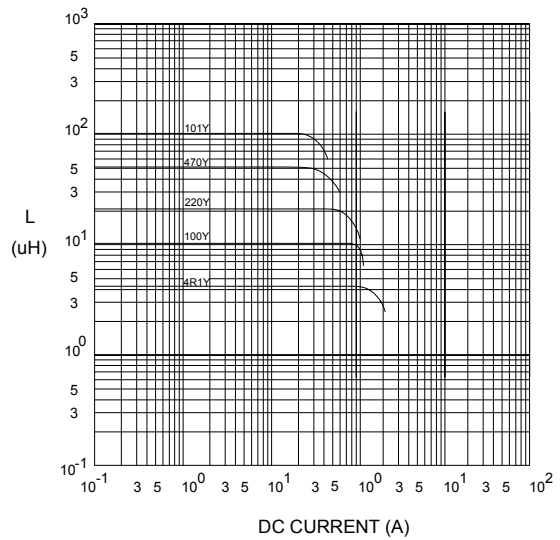

NOTE : Specifications subject to change without notice. Please check our website for latest information.



RoHS Compliant

01.10.2010



SUPERWORLD ELECTRONICS (S) PTE LTD

RECOMMENDED SOLDERING CONDITIONS REFLOW SOLDERINGS

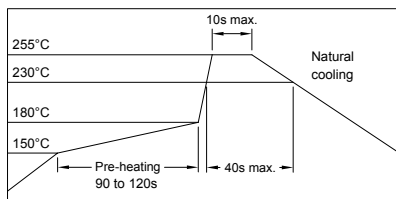

8. PACKAGING INFORMATION :

(1) CONFIGURATION

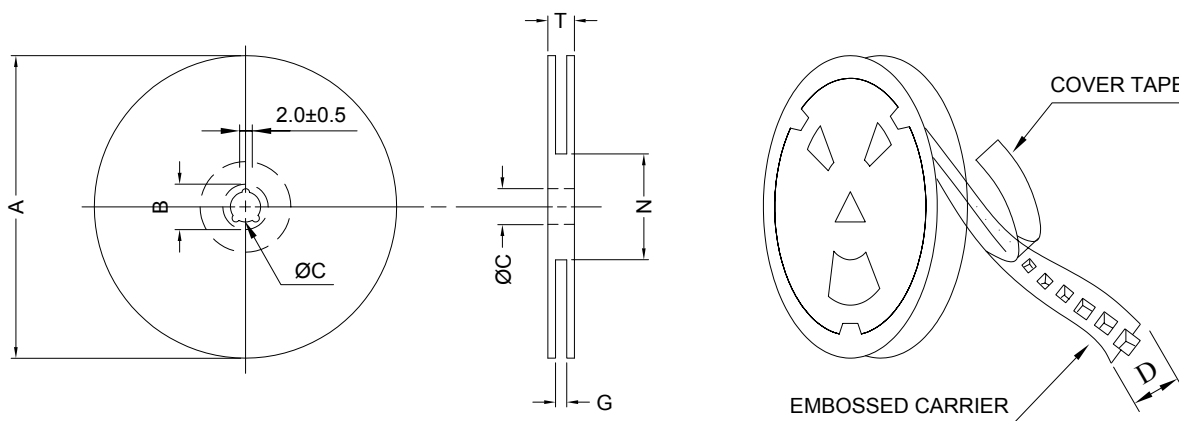

* CARRIER TAPE WIDTH : D

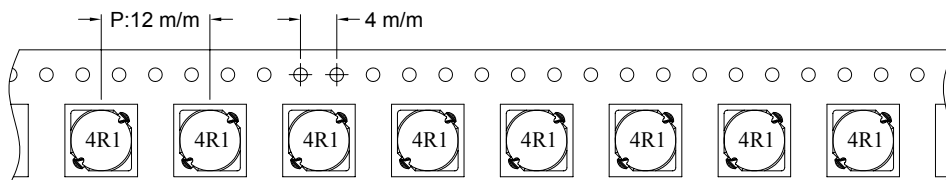

(2) DIMENSIONS

Unit:m/m

STYLE	A	B	C	D	G	N	T
13-16	330	21±0.8	13	16	18 ⁺⁰	50 ⁻⁰	22.4

(3) Q'TY & G.W. PER PACKAGE

SERIES	INNER : REEL			OUTER : CARTON		
	Q'TY (PCS)	G.W. (gw)	STYLE	Q'TY (PCS)	G.W. (Kg)	SIZE (cm)
SSC0502	2000	2400	13-16	12000	17.9	40 x 40 x 24



RoHS Compliant

NOTE : Specifications subject to change without notice. Please check our website for latest information.

01.10.2010

9. RELIABILITY AND TEST CONDITION :

TEST ITEM	SPECIFICATION	TEST CONDITION
SOLDERABILITY	MORE THAN 90% OF THE TERMINAL ELECTRODE SHALL BE COVERED WITH FRESH SOLDER.	PREHEAT : 125±25°C FOR 60 SECONDS SOLDER : 99%Sn/0.3%Ag/0.7%Cu OR EQUIVALENT SOLDER TEMP. : 245±5°C FLUX : ROSIN DIP TIME : 4±1 SECONDS
THERMAL SHOCK TEST (TEMP. CYCLE)	INDUCTANCE SHALL NOT CHANGE MORE THAN ±20%	ROOM TEMP. → -25±2°C 15 MINUTES → 30 MINUTES ROOM TEMP. → 85±2°C 15 MINUTES → 30 MINUTES TOTAL : 50 CYCLES
HUMIDITY RESISTANCE TEST		TEMPERATURE : 40±2°C HUMIDITY : 90 ~ 95% APPLIED CURRENT : PER SPEC. TIME : 500 HOURS
HIGH TEMP. RESISTANCE TEST		TEMPERATURE : 85±2°C APPLIED CURRENT : PER SPEC. TIME : 500 HOURS

10. UL CARD :

OBMW2		November 30, 2000		
Magnet Wire - Component				
PACIFIC ELECTRIC WIRE & CABLE (SHENZHEN) CO LTD				E201757
607 BAOLONG INDUSTRIAL ESTATE LONGGANG, SHENZHEN GUANGDONG CHINA				
	Coating Type		ANSI	TI
Mtl Dsg	BC	TC	Type	
UEW/U	Polyurethane	—	—	130
PEW/U	Polyester	—	MW5-C	155°C
PEWH/U	Modified Polyester	—	MW30-C	180
PEW-NY/U	Polyester	Polyamide	MW24-C	155
HAI/U	Polyester(Amide)(Imide)	Polyamideimide	MW35,73	200
UEW-NY/U	Polyurethane	Polyamide	MW80-C	155
			MW28-C	130
<p>Marking: Company name and material designation or marked designation on package or reel, and Recognized Component Mark.</p> <p>See General Information Preceding These Recognitions</p>				
1/3/2001	Underwriters Laboratories Inc.		Card 1 of 2	



RoHS Compliant

NOTE : Specifications subject to change without notice. Please check our website for latest information.

