

	兴化市悦馨电子有限公司 样品承认书 <i>Specifications</i>	http://www.xhyxdz.com Tel: +86-523-83722059 Fax: +86-523-83722259
	地址: 江苏省兴化市陈堡镇工业园区	页码 PAGE: 1/5

客户名称 Customer Name	
品名 Rariety	magnetic buzzer (within circuit)
型号 Part No	YX-YT12095/TMB12A
样品日期 Model Date	

客户承认签署

签定结果:		
核准/Approved:	审核/Checked:	经办/Designed:

供应商确认签署

核准/Approved:	审核/Checked:	经办/Designed:
王明娟	时卫玲	朱素平

【 承认后请签回一份! Thank you very much! 】



兴化市悦馨电子有限公司
样品承认书
Specifications

http://www.xhyxdz.com
 Tel: +86-523-83722059
 Fax: +86-523-83722259

地址: 江苏省兴化市陈堡镇工业园区

页码 PAGE: 2/5

Part No: YX-YT12095/TMB12A

性能参数 Electrical Characteristics

Rated Voltage(VDC)	3	5	12	24
Operating Voltage (VDC)	2~5	4~8	8~15	18-30
*Rated Current (m A)	≤30	≤30	≤30	≤30
*Sound Output at 10cm (dB)	≥88	≥88	≥88	≥88
Resonant Frequency (Hz)	2300±300			
Tone	Continuous			
Operating Temperature (°C)	-30~+85			
Storage Temperature (°C)	-40~+85			
Weight (g)	2.0			
Material	PBT			

Environmental Protection Regulation

带*号指标需要在额定电压下测试 *Applying rated voltage

外观尺寸 Appearance Drawing

(单位: 毫米) (UNIT: mm)

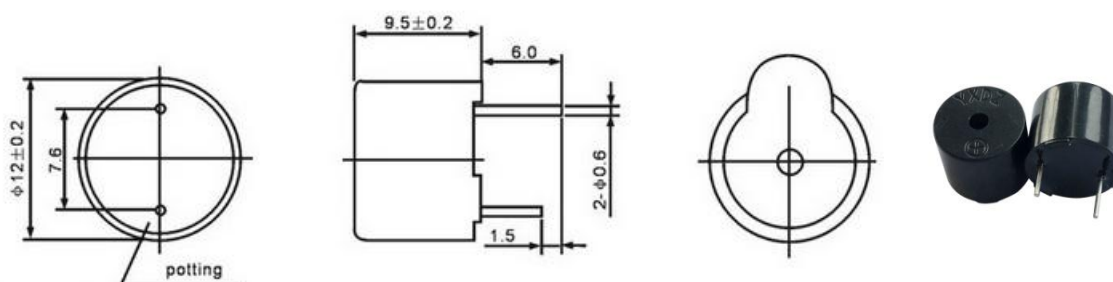



兴化市悦馨电子有限公司

样品承认书

Specifications

http://www.xhyxdz.com

Tel: +86-523-83722059

Fax: +86-523-83722259

地址: 江苏省兴化市陈堡镇工业园区

页码 PAGE: 3/5

Part No: YX-YT12095/TMB12A

测试方法 TESTING METHOD

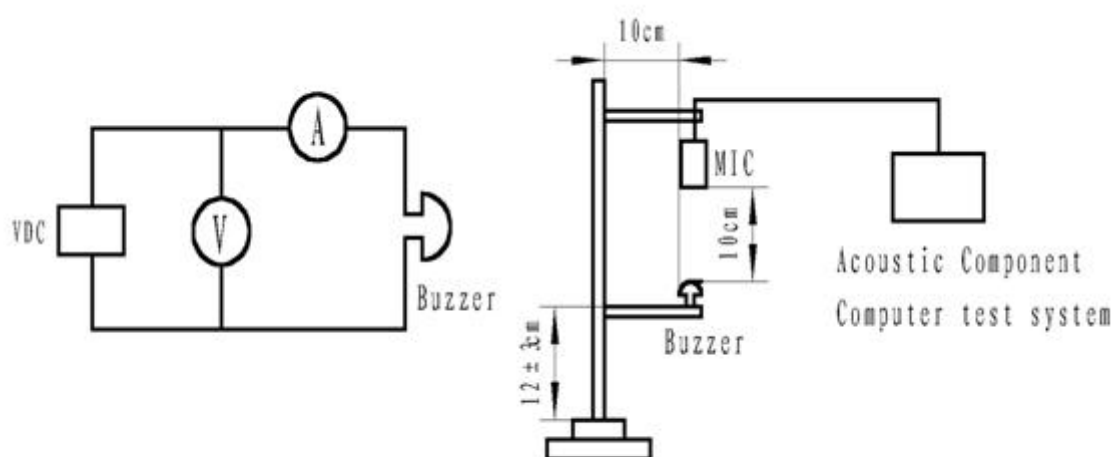

频响曲线 FREQUENCY RESPONSE

dB-V

mA-V

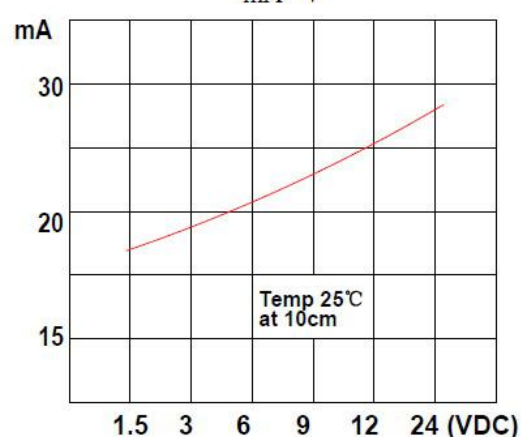
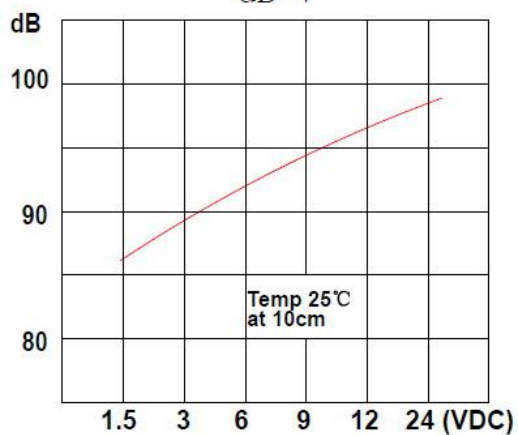



兴化市悦馨电子有限公司

样品承认书

Specifications

http://www.xhyxdz.com

Tel: +86-523-83722059

Fax: +86-523-83722259

地址: 江苏省兴化市陈堡镇工业园区

页码 PAGE: 4/5

Part No: YX-YT12095/TMB12A

可靠性测试 RELIABLY TEST

NO	项目 ITEM	测试条件 TESTING CONDITION	试验后要求 VARIANCE AFTER TEST
1	湿热试验 Humidity	蜂鸣器置于温度 $40 \pm 2^\circ\text{C}$, 湿度 $93(+2/-3)\%RH$ 试验箱中, 96 小时后, 常温下 2 小时后测试	<p>After test(1~8item), the Buzzer S.P.L . difference shall be within $\pm 10\text{dB}$, Frequency difference shall be within $\pm 0.5\text{KHz}$. and the appearance not exist any change to be harmful to normal operation(e.g. cracks, rusts, damages and especially distortion).</p> <p>在 1-8 项试验后, 蜂鸣器的声压变化值在 $\pm 10\text{dB}$ 之内, 频率变化在 $\pm 0.5\text{KHz}$ 之内。外观无变化(例如: 开裂、生锈、损伤、变形等现象)。</p>
		$40 \pm 2^\circ\text{C}$, $93(+2/-3)\%RH$, 96HRS	
2	高温测试 High temp.	蜂鸣器放置在 $+80 \pm 2^\circ\text{C}$ 中, 96 小时后测试性能指标	
		$+80 \pm 2^\circ\text{C}$, 96HRS	
3	低温测试 Low temp.	将蜂鸣器放置在 $-30 \pm 2^\circ\text{C}$ 中, 96 小时后测试性能指标	
		$-30 \pm 2^\circ\text{C}$, 96HRS	
4	温度循环测试 Temperature Cycling	蜂鸣器在 -30°C 暴露 30min, 在 80°C 暴露 30min, 五次循环后, 试验后在常温下恢复 2 小时	
		$-30 \pm 2^\circ\text{C}$, 30minutes room temp. 15 minutes $+80 \pm 2^\circ\text{C}$, 30 minutes room temp. 15 minutes 5 cycles	
5	跌落测试 Drop test	跌落高度 80cm, 6 个不同方向整箱跌落到水泥地, 试验后进行测试	
		packed in cartons dropped in 6 directions from height of 80cm to the concrete floor	
6	振动测试 Vibration test	将蜂鸣器置于 10~30Hz、振幅在 1.5mm、X Y Z 轴线方向上振动 2 小时后测试	
		test from the directions of X Y Z for 2 hours To-and-fro. sweep time (from 10 to 30Hz and then from 30 to 10Hz) under single amplitude of 1.5mm is 1 minute.	
7	焊锡耐热性测试 Solder heat resistance	插针浸入松香 5 秒, 然后再浸入 $+260 \pm 5^\circ\text{C}$ 的锡炉中 3 ± 0.5 秒, 插针表面应覆盖一层光滑明亮的焊料。	
		Lead terminals are immersed in rosin for 5 seconds and then immersed in solder bath of $+260 \pm 5^\circ\text{C}$ for 3 ± 0.5 seconds.	
8	Terminal Strength Pulling 插针强度测试	插针应承受 9.8N 拉力, 拉力时间 10 秒, 插针无松动和脱落等现象	
		The force 10 seconds of 9.8N is applied go each terminal in axial direction	



兴化市悦馨电子有限公司

样品承认书

Specifications

<http://www.xhyxdz.com>

Tel: +86-523-83722059

Fax: +86-523-83722259

地址: 江苏省兴化市陈堡镇工业园区

页码 PAGE: 5/5

Part No: YX-YT12095/TMB12A

包装方式 PACKING METHOD

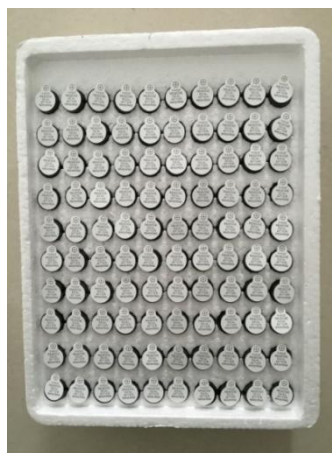

Qty:100 pcs



Qty:1000 pcs



Qty:6000 pcs



- 1.1000pcs per box
- 2.6boxes per carton
- 3.Total 6000pcs per carton
- 4.Volume:50*42*27cm