

Low Noise Power Supply LSI Series for Audio System

# Ultra Low Noise Low Dropout Regulator for Audio System

## BD37201NUX

### General Description

BD37201NUX is a low saturation series regulator of low noise ( $4.72\mu\text{Vrms}$ ) which is most suitable to high quality audio system. It operates at 2.7V to 5.5V and capable of supplying a maximum load of 500mA.

BD37201NUX has a high PSRR and good input transient fluctuation characteristic which makes it suitable for the stabilization of DC/DC converter output, and an ideal power supply to high precision analog circuits such as D/A converter (DAC) or Clock generator.

Furthermore, when BD37201NUX is placed in standby mode, the supply current can be as small as  $0\mu\text{A(Typ)}$  which can greatly reduce power consumption.

### Key Specifications

- Input Voltage Range: 2.7V to 5.5V
- Output Voltage Range: 1.0V to 4.5V
- Output Current: 0.5A(Max)
- Output Voltage Noise:  $4.72\mu\text{Vrms}$ (10 to 100kHz)
- PSRR: 74dB(100Hz),  $\geq 50\text{dB}$ (1MHz)
- Input Transient Response:  $\leq 5\text{mV}(1.0\text{V}/\mu\text{s})$
- Standby Current:  $0\mu\text{A(Typ)}$
- Operating Temperature Range:  $-40^\circ\text{C}$  to  $+85^\circ\text{C}$

### Package

VSON008X2030

### W(Typ) x D(Typ) x H(Max)

2.00mm x 3.00mm x 0.60mm

### Features

- Ultra Low Noise, High PSRR
- Stable at  $1\mu\text{F}$  ceramic input and output capacitors
- Standby Mode that is controlled by Enable pin
- Dropout Voltage: 200mV (at 500mA load)
- Under Voltage Lockout Protection, Current Limit and Short Circuit Protection, Thermal Shutdown Protection

### Applications

- High quality audio equipment
- Power supply for D/A converter and Clock generator
- The other application which require low noise



### Typical Application Circuit

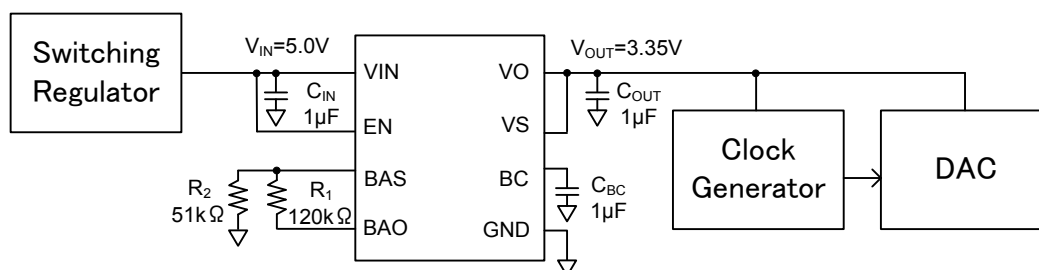

Figure 1. Basic Application Circuit Diagram ( $V_{\text{OUT}}=3.35\text{V}$ )

Pin Configuration

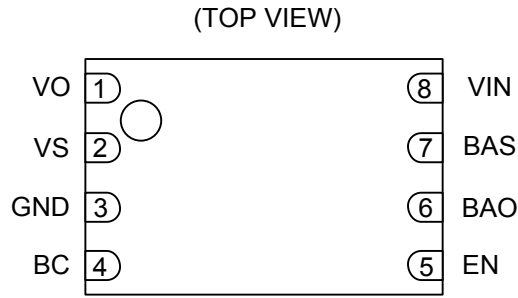

Figure 2. Pin Configuration

Pin Description

Pin No.	Pin Name	Function
1	VO	Output voltage
2	VS	Output voltage feedback
3	GND	Ground
4	BC	Bypass capacitor pin connected to ground
5	EN	Enable
6	BAO	Programmed voltage output
7	BAS	Programmed voltage feedback
8	VIN	Input voltage

(Note) The exposed pad should be connected to GND pattern.

Block Diagram

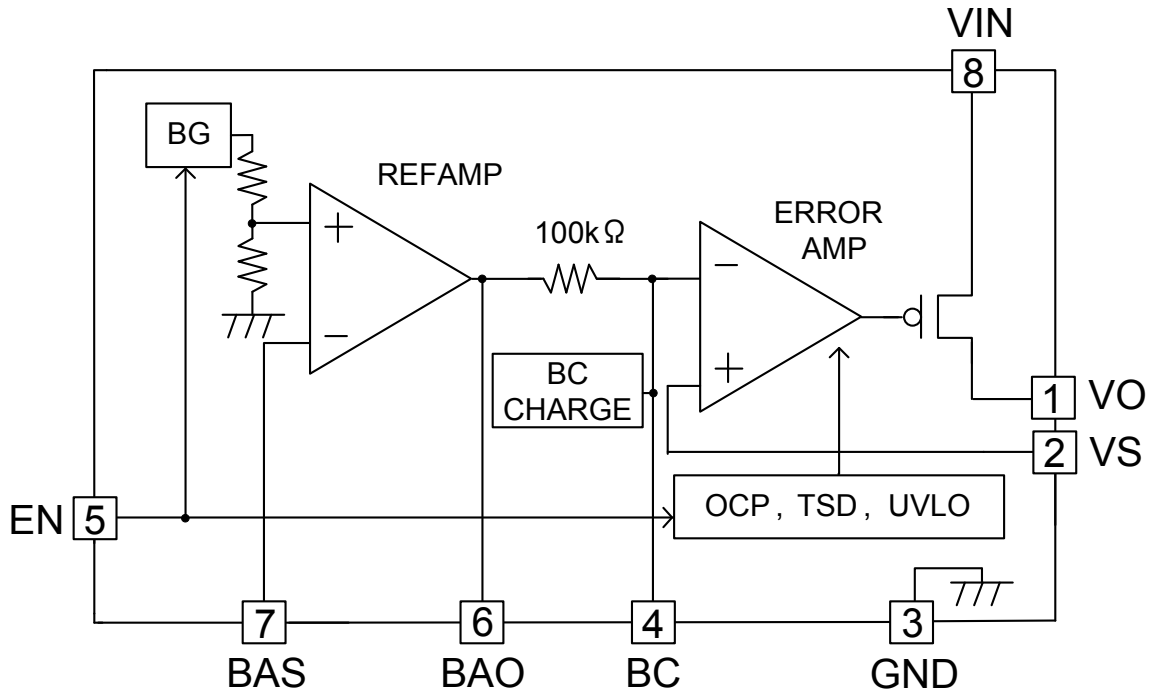

Figure 3. Block Diagram

## Description of Block

1. Enable  
Assuming EN terminal is set to L, the IC can be set to standby state. In standby state, the output is OFF and since it will be in static state, the power consumption can be reduced.
2. Rising ,Falling, and EN Controlled Timing

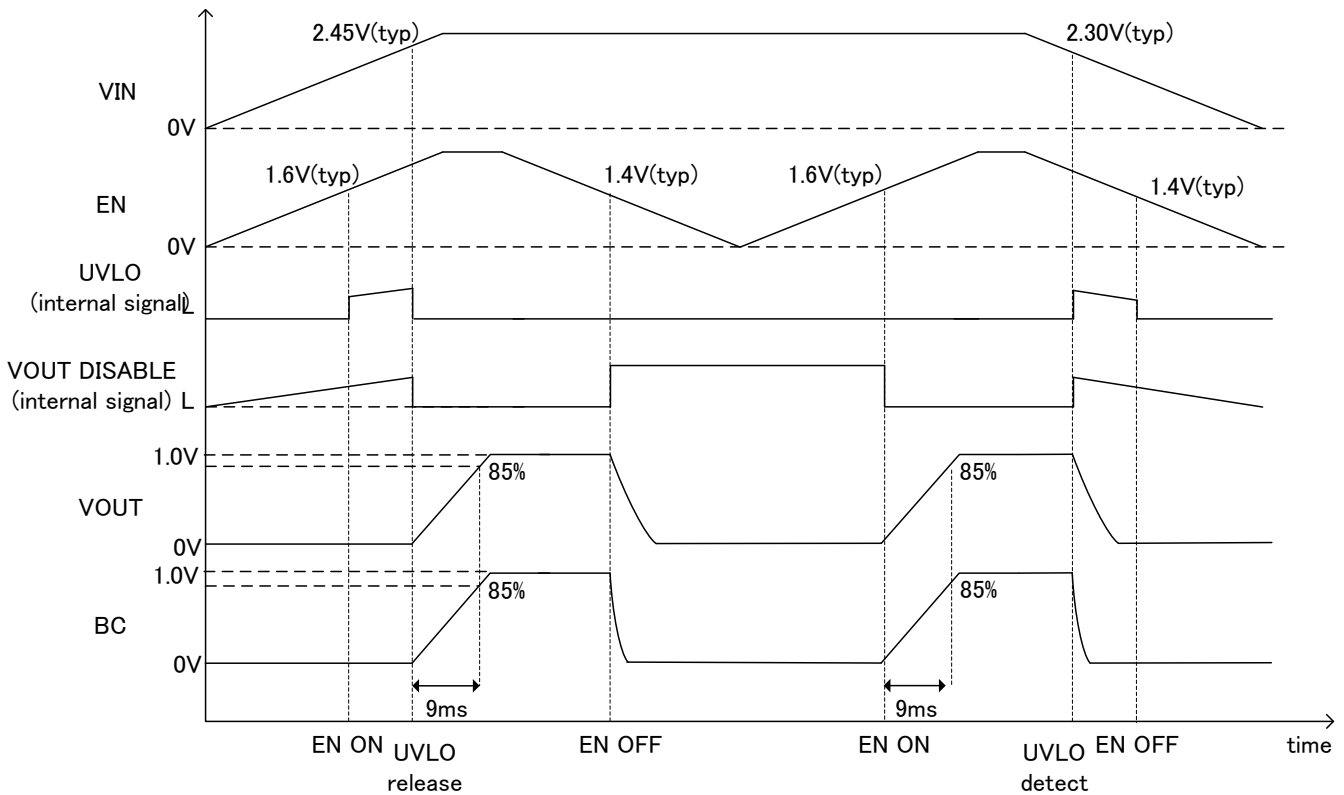

Figure 4. The Waveform During VIN/EN Rising and Falling  
(When at BC Capacitor 1 $\mu$ F and Output 1V Settings)

It will operate if EN is ON and UVLO (Under Voltage Lockout) is released. In addition, when EN is OFF or UVLO is detected, the regulator operation stops.

The maximum slew rate of input voltage has to be set under 1V/ $\mu$ s.

3. Soft Start Function  
In BD37201NUX, there exists a function that limits the rising speed of output when EN rises by the capacitor connected to BC due to decrease of inrush current of output. The rising speed depends on the capacitance value connected to BC and on the output programmed voltage. It is about 9ms (Typ) if capacitance is 1 $\mu$ F and output programmed voltage is 1V, and almost 30ms (Typ) if output programmed voltage is set to 3.35V.
4. REFAMP  
REFAMP settle its output voltage through the reference voltage 1.0V (Typ) and external resistors.
5. BC Terminal  
Noise at the output voltage of REFAMP will be reduced because of the internal resistor and the external BC capacitor. In addition to it, the external BC capacitor also has a soft start function so the rising speed can be adjusted by this value. The higher value of capacitor will decrease the noise but the softstart time will be longer.
6. ERRAMP  
The ERRAMP outputs the voltage set in REFAMP at closed gain 1 time. VS terminal must be connected to OUT by all means. In addition, VS terminal can decrease a voltage drop by the pattern resistance on the OUT course by returning the voltage from the supply point.

**Absolute Maximum Rating (Ta = 25°C)**

Parameter	Symbol	Rating	Unit
Power Supply Voltage	V <sub>IN</sub>	-0.3 to +7.0	V
Terminal Voltage (the other PINs)	V <sub>PIN</sub>	-0.3 to +7.0	V
Operating Temperature Range	Topr	-40 to +85	°C
Storage Temperature Range	Tstg	-55 to +150	°C
Junction Temperature	Tjmax	150	°C

**Caution:** Operating the IC over the absolute maximum ratings may damage the IC. The damage can either be a short circuit between pins or an open circuit between pins and the internal circuitry. Therefore, it is important to consider circuit protection measures, such as adding a fuse, in case the IC is operated over the absolute maximum ratings.

**Recommended Operating Conditions (Ta = -40°C to +85°C)**

Parameter	Symbol	MIN	TYP	MAX	Unit
Power Supply Voltage	V <sub>IN</sub>	2.7	-	5.5	V
Output Voltage Setting is within a Possible Range	V <sub>OUT</sub>	1.0	-	4.5	V
Output Current	I <sub>OUT</sub>	-	-	0.5 (Note 1)	A

(Note 1) ASO should not be exceeded.

**Operating Condition**

Parameter	Symbol	MIN	TYP	MAX	Unit	Conditions
Input Capacitor	C <sub>IN</sub>	0.47 (Note 2)	1	-	μF	Ceramic capacitors are recommended
Output Capacitor	C <sub>OUT</sub>	0.22 (Note 2)	1	-	μF	Ceramic capacitors are recommended
BC Capacitor	C <sub>BC</sub>	0.01 (Note 2)	1	-	μF	Ceramic capacitors are recommended

(Note 2) Please set the capacity of the condenser not to be less than the minimum in consideration of temperature or DC bias properties.

**Thermal Resistance (Note 3)**

Parameter	Symbol	Thermal Resistance (Typ)		Unit
		1s (Note 5)	2s2p (Note 6)	
VSON008X2030				
Junction to Ambient	θ <sub>JA</sub>	308.3	69.6	°C/W
Junction to Top Characterization Parameter (Note 4)	Ψ <sub>JT</sub>	43	10	°C/W

(Note 3) Based on JESD51-2A(Still-Air)

(Note 4) The thermal characterization parameter to report the difference between junction temperature and the temperature at the top center of the outside surface of the component package.

(Note 5) Using a PCB board based on JESD51-3.

Layer Number of Measurement Board	Material	Board Size
Single	FR-4	114.3mm x 76.2mm x 1.57mmt
Top		
Copper Pattern	Thickness	
Footprints and Traces	70μm	

(Note 6) Using a PCB board based on JESD51-5, 7.

Layer Number of Measurement Board	Material	Board Size	Thermal Via (Note 7)		
			Pitch	Diameter	
4 Layers	FR-4	114.3mm x 76.2mm x 1.6mmt	1.20mm	Φ0.30mm	
Top		2 Internal Layers		Bottom	
Copper Pattern	Thickness	Copper Pattern	Thickness	Copper Pattern	Thickness
Footprints and Traces	70μm	74.2mm (Square)	35μm	74.2mm (Square)	70μm

(Note 7) This thermal via connects with the copper pattern of all layers.

**Electrical Characteristics** (Unless otherwise specified,  $V_{IN} = V_{OUT} + 1.0V$  or  $2.7V$  whichever is greater  $V_{OUT} = 1.0V$   
 $T_a = 25^\circ C$   $C_{OUT} = 1\mu F$   $C_{BC} = 1\mu F$   $I_{OUT} = 5mA$   $V_{IN} = V_{EN}$ )

Parameter	Symbol	MIN	TYP	MAX	Unit	Conditions
Circuit Current	$I_{CC}$	-	1.33	2.3	mA	-
Standby Current	$I_{STB}$	-	0.0	1.0	$\mu A$	$V_{IN} = 5.5V$
Reference Voltage	$V_{REF}$	0.99	1.00	1.01	V	BAS Voltage
Line Regulation	$D_{VI}$	-	1	20	mV	$V_{IN} = 2.7V$ to $5.5V$
Load Regulation	$D_{VL}$	-	3	20	mV	$I_{OUT} = 0mA$ to $500mA$
Dropout Voltage	$V_{SAT}$	-	0.2	0.5	V	$I_{OUT} = 500mA$
PSRR 1kHz	$PSRR_{1kHz}$	-	90	-	dB	$f = 1kHz$
PSRR 1MHz	$PSRR_{1MHz}$	-	55	-	dB	$f = 1MHz$ , $C_{OUT} = 47\mu F$
Output Noise Voltage	$V_{NOISE}$	-	4.7	-	$\mu V_{rms}$	$BW = 10Hz$ to $100kHz$ , $C_{BC} = 10\mu F$ , $I_{OUT} = 500mA$
Output Current Capability	$I_{OCP}$	500	-	-	mA	-
UVLO Detect Voltage	$V_{UVLOH}$	2.10	2.30	2.50	V	-
UVLO Release Voltage	$V_{UVLOL}$	2.25	2.45	2.65	V	-
EN Detecting Voltage Range	$V_{THENH}$	2.20	-	$V_{IN}$	V	-
EN Release Voltage Range	$V_{THENL}$	0.00	-	0.60	V	-
EN Input Current	$I_{EN}$	-	1.23	2.10	$\mu A$	$V_{EN} = 3V$

**Application Information** (Unless otherwise specified,  $V_{IN} = V_{OUT} + 1.0V$  or  $2.7V$  whichever is greater  $V_{OUT} = 1.0V$   $T_a = 25^\circ C$   
 $C_{OUT} = 1\mu F$   $C_{BC} = 1\mu F$   $I_{OUT} = 5mA$ )

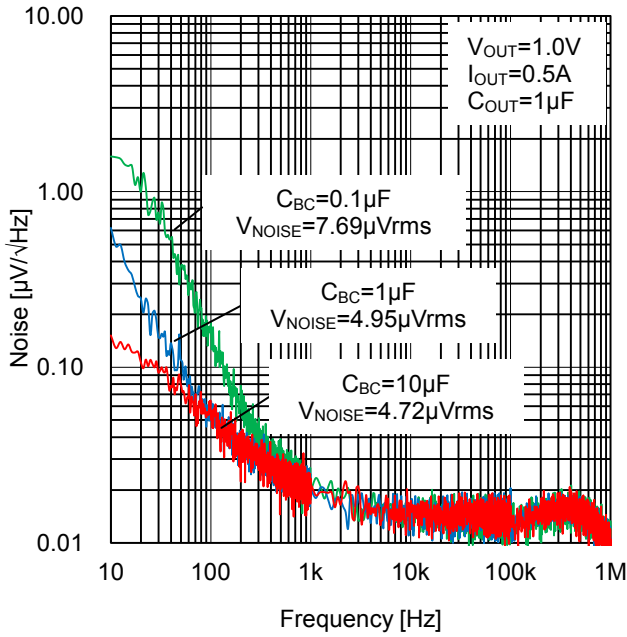

Figure 5. Noise vs  $C_{BC}$

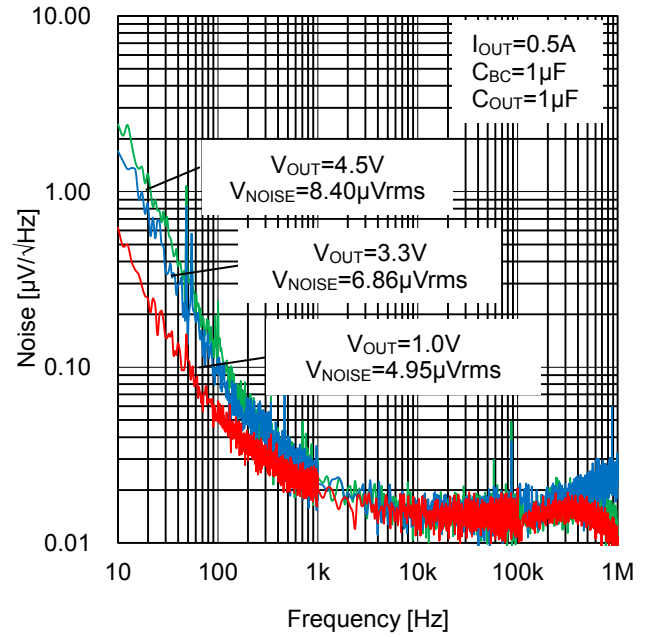

Figure 6. Noise vs  $V_{OUT}$

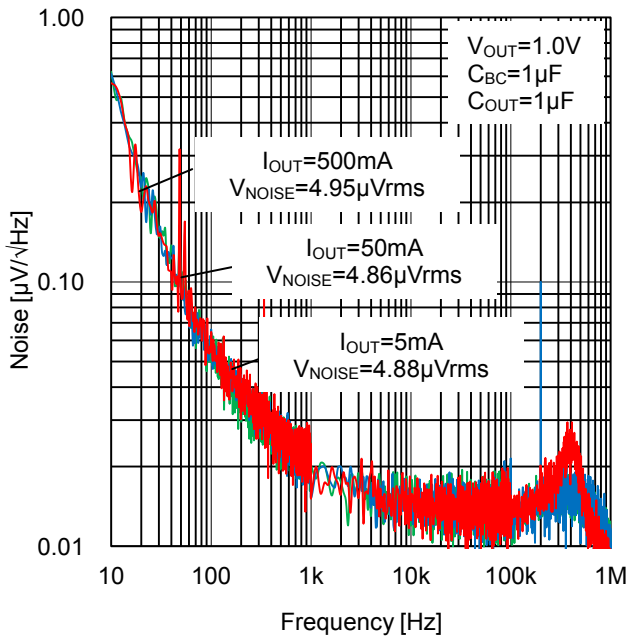

Figure 7. Noise vs  $I_{OUT}$

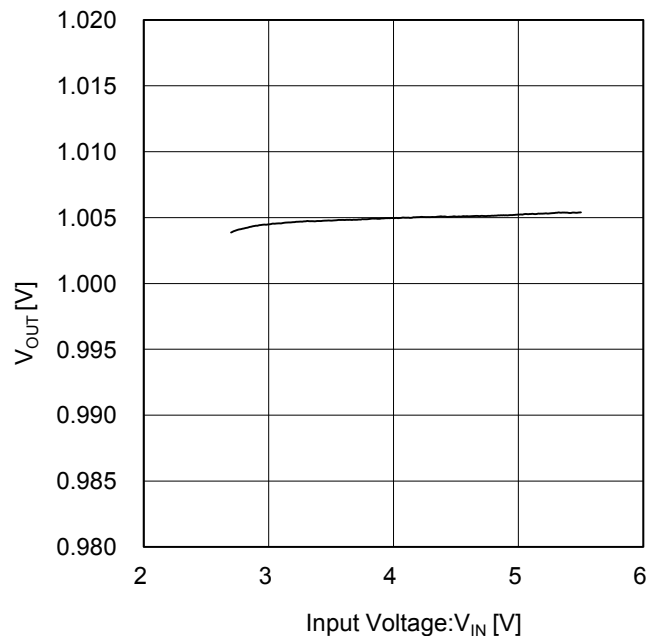

Figure 8. Line Regulation

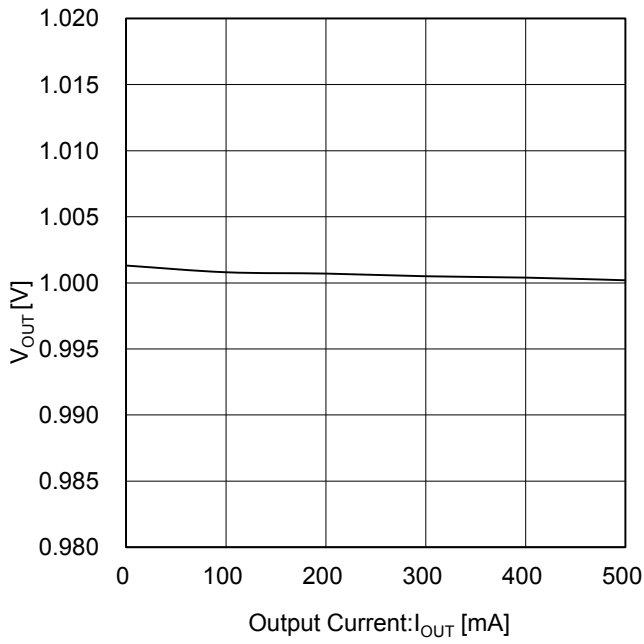

Figure 9. Load Regulation

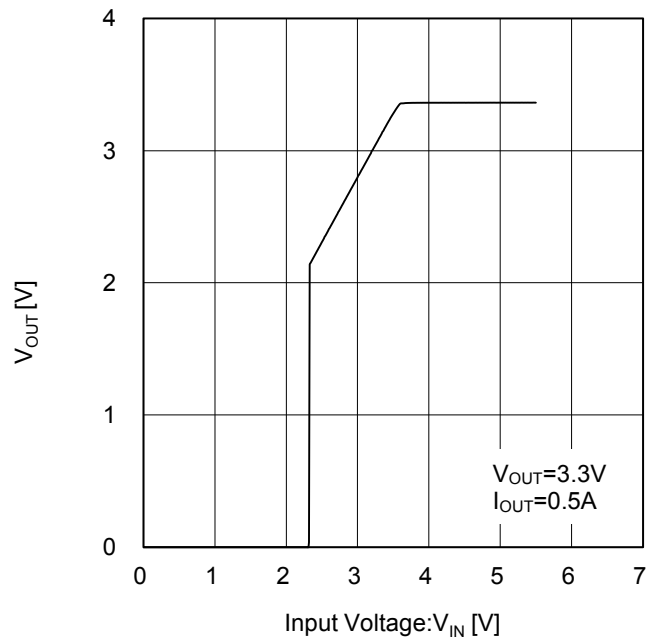

Figure 10.  $V_{IN}$  vs  $V_{OUT}$

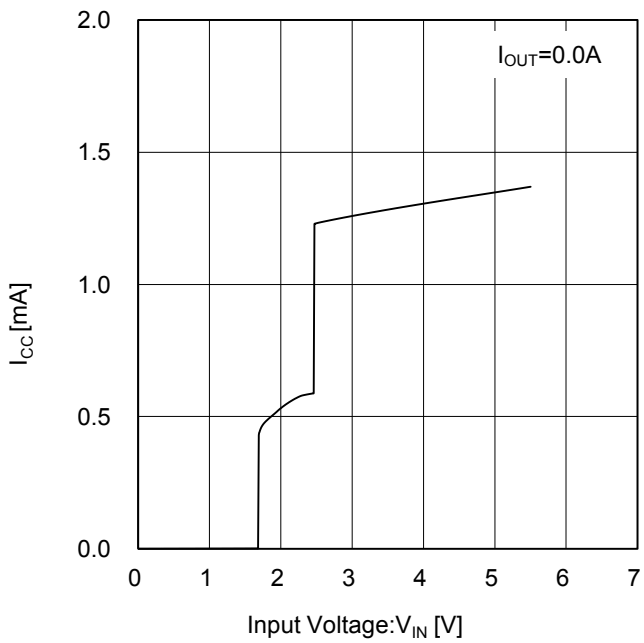

Figure 11.  $I_{CC}$  vs  $V_{IN}$

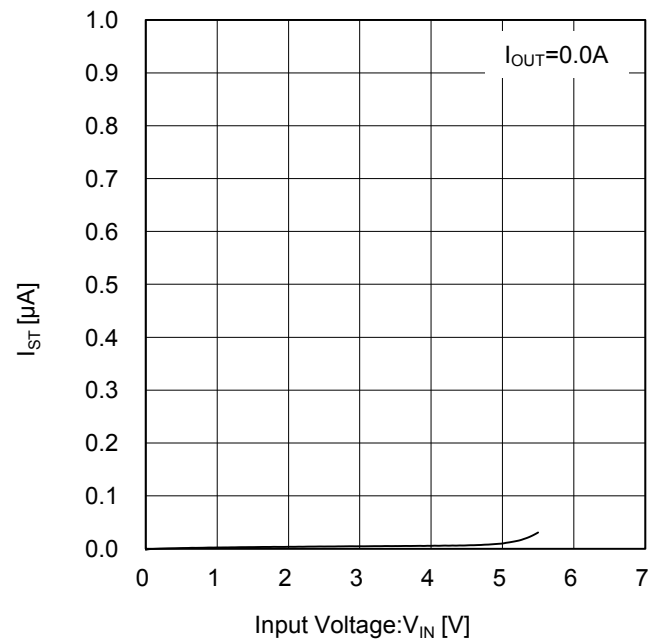

Figure 12. Stand by Current vs  $V_{IN}$

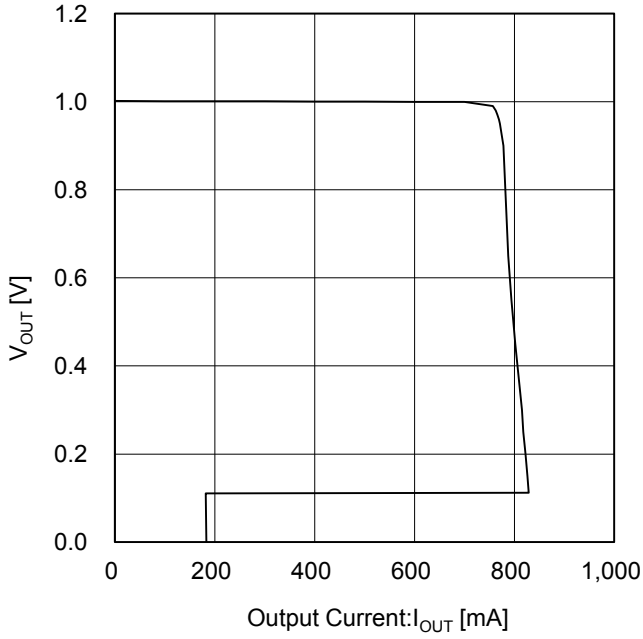

Figure 13. Output Voltage vs Output Current

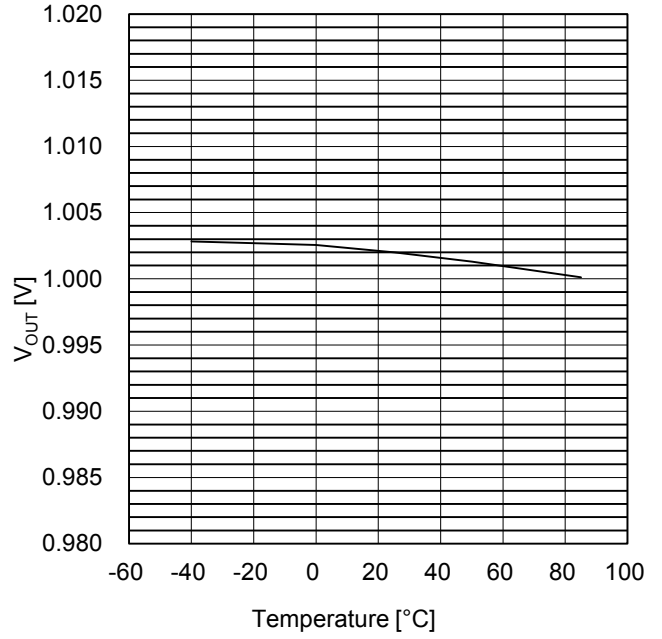

Figure 14. Output Voltage vs Temperature

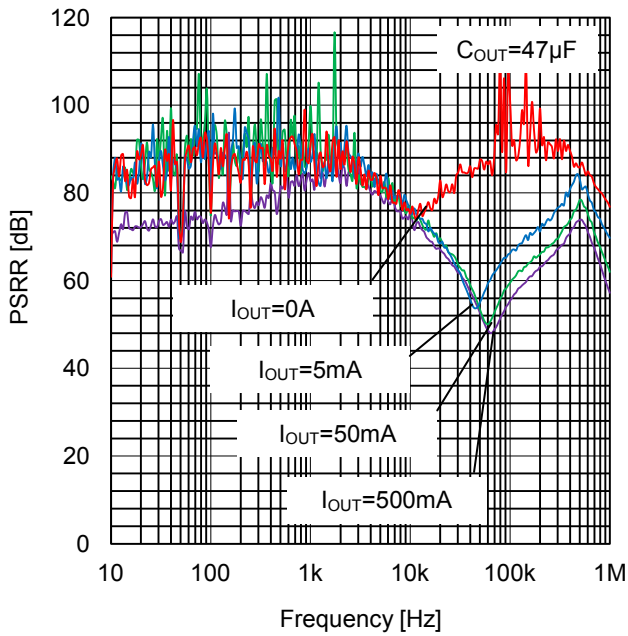

Figure 15. Power-Supply Rejection Ratio vs  $I_{OUT}$

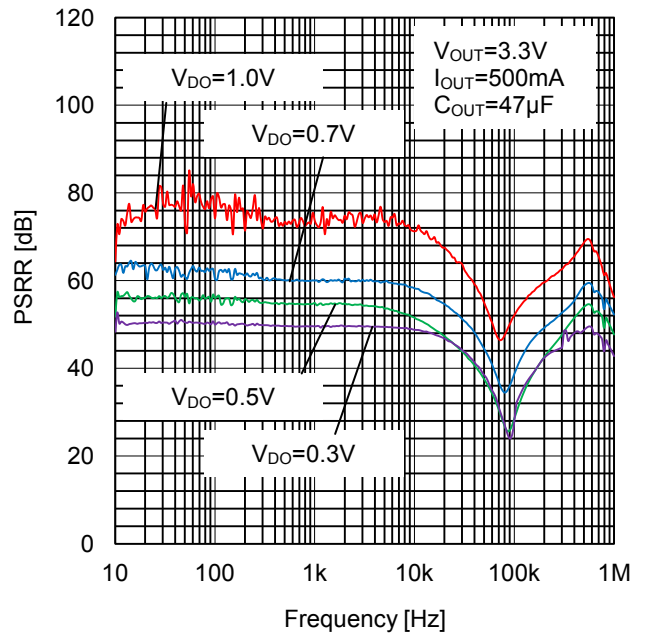

Figure 16. Power-Supply Rejection Ratio vs  $V_{DO}$

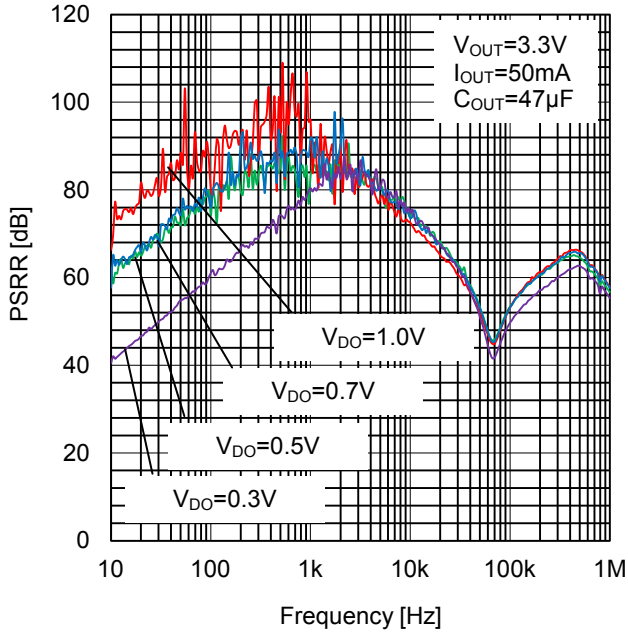

Figure 17. Power-Supply Rejection Ratio vs  $V_{DO}$

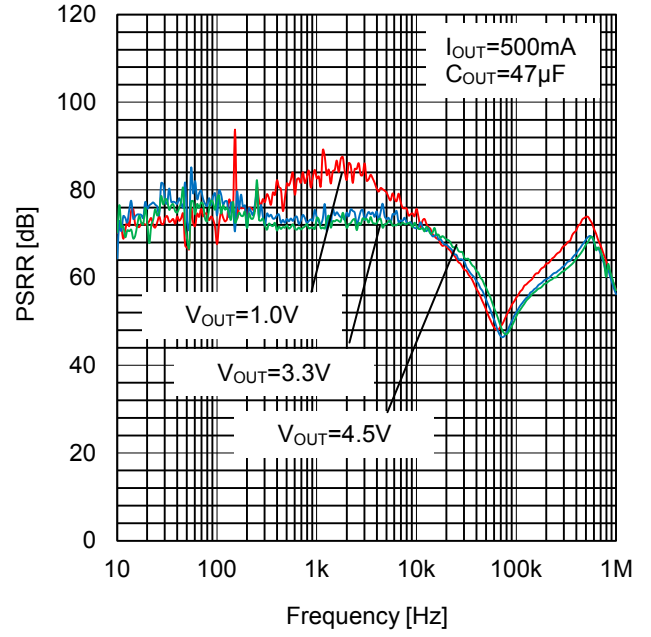

Figure 18. Power-Supply Rejection Ratio vs  $V_{OUT}$

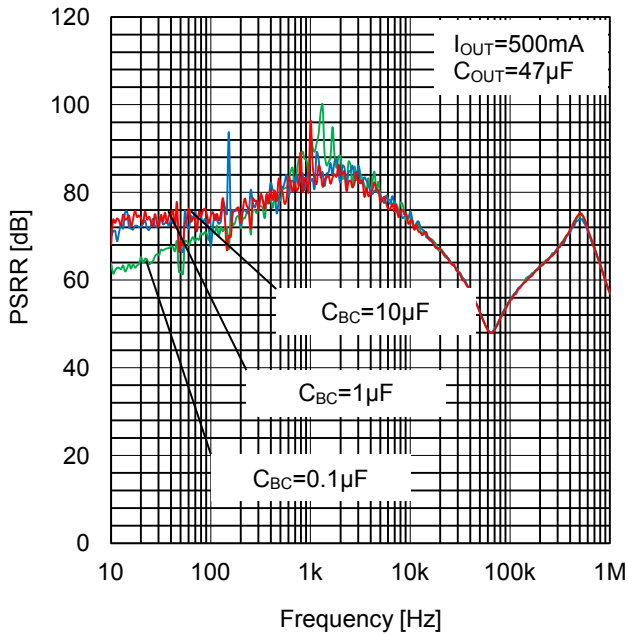

Figure 19. Power-Supply Rejection Ratio vs  $C_{BC}$

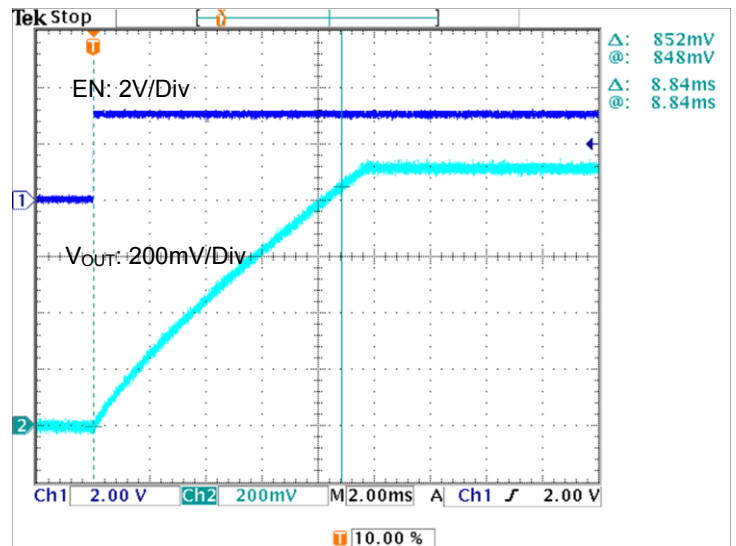

Figure 20. Soft Start

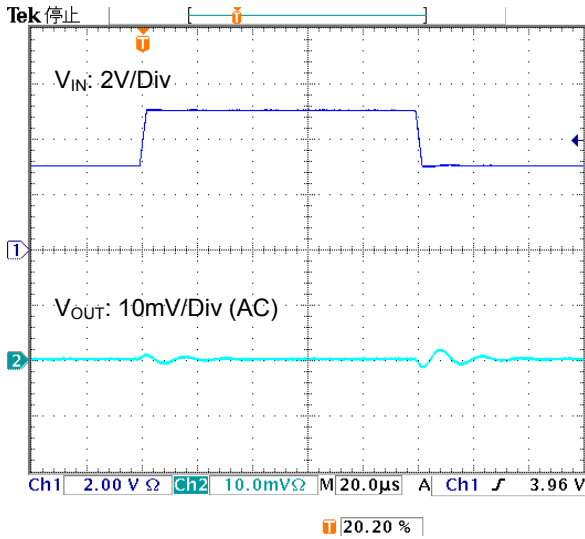

Figure 21. Line Transient  
(I<sub>OUT</sub>=500mA Slew Rate=1V/μs)

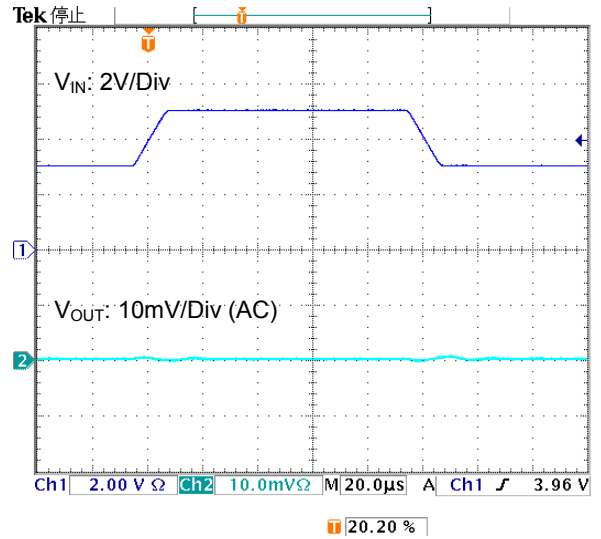

Figure 22. Line Transient  
(I<sub>OUT</sub>=500mA Slew Rate=0.2V/μs)

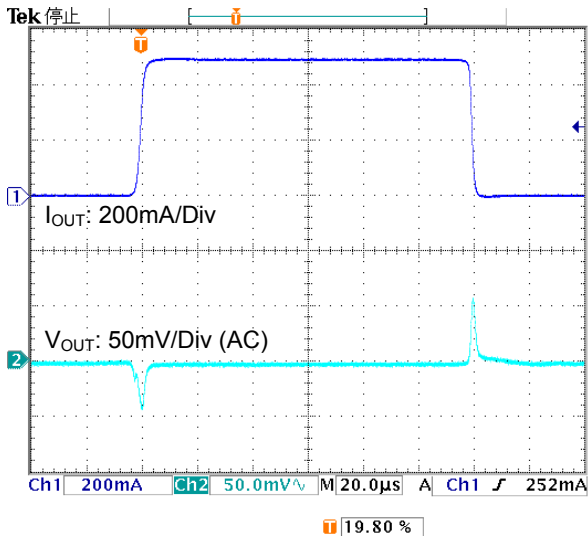
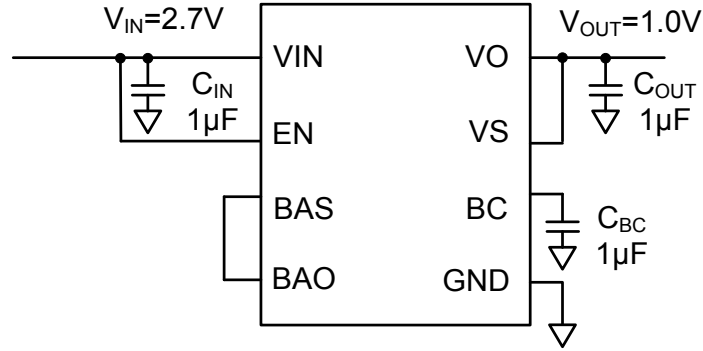

Figure 21. Load Transient  
(I<sub>OUT</sub>=0mA to 500mA)

1. Application Examples



(Note) This application example is just one case. Actual setting will be decided after a thorough evaluation and verification.

Parts	Maker	Value	Parts
C <sub>IN</sub>	Murata	1µF	GCM188R71E105KA49
C <sub>OUT</sub>	Murata	1µF	GCM188R71E105KA49
C <sub>BC</sub>	Murata	1µF	GCM188R71E105KA49

Figure 24. Application Circuit 1 (V<sub>OUT</sub>=1.0V)

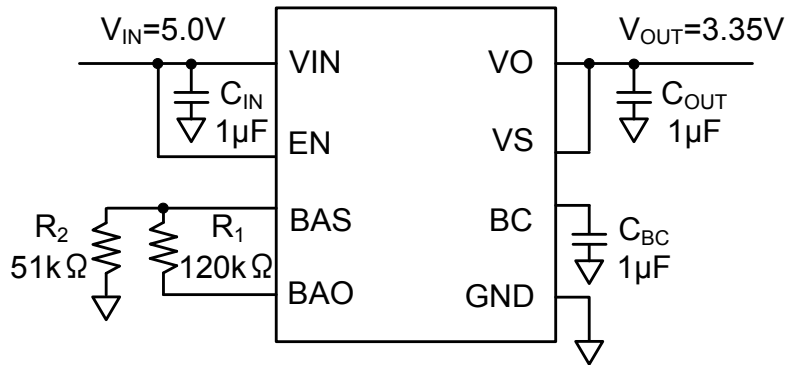

(Note) This application example is just one case. Actual setting will be decided after a thorough evaluation and verification.

Parts	Maker	Value	Part Number
R <sub>1</sub>	ROHM	120kΩ	MCR03EZPD
R <sub>2</sub>	ROHM	51kΩ	MCR03EZPD
C <sub>IN</sub>	Murata	1µF	GCM188R71E105KA49
C <sub>OUT</sub>	Murata	1µF	GCM188R71E105KA49
C <sub>BC</sub>	Murata	1µF	GCM188R71E105KA49

Figure 25. Application Circuit 2 (V<sub>OUT</sub>=3.35V)

## 2. Selection of Components Externally Connected

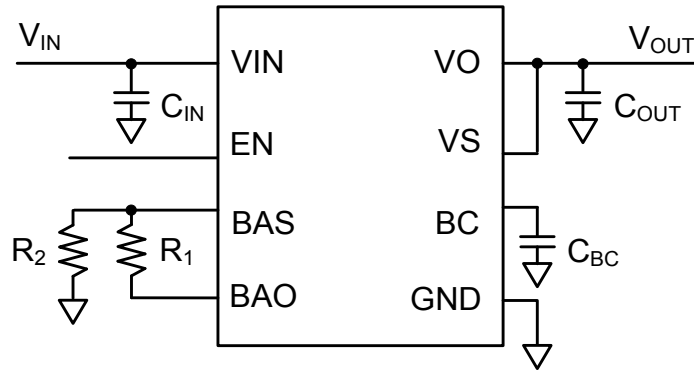

Figure 26. External Components Connection

### (1) Output Voltage Setting

To set output voltage, connect resistance of  $R_1$  between BAO-BAS and connect resistance of  $R_2$  in between BAS-GND. The value of  $R_1$  and  $R_2$  is set that  $R_1 + R_2$  becomes more than 100k $\Omega$ . In addition, the resistance for voltage setting is recommended the one that is less than 1% accuracy. In the case of 1V setting, please short BAS with BAO.

$$V_{OUT} = V_{BAS} \times \frac{R_1 + R_2}{R_2} \quad [V]$$

$$V_{BAS} = 1.0V \text{ (Typ)}$$

### (2) Output Capacitor $C_{OUT}$

Output capacitor should be selected more than 0.22 $\mu$ F considering about the voltage modulation, thermal characteristics, and distribution of the value. Installation of capacitor in the position near the pin in between output terminal and GND is recommended. In addition, the rated voltage of condenser shall be set with enough margin with respect to output voltage of rated voltage of condenser.

### (3) Input Capacitor $C_{IN}$

Installation of input capacitor in the position close to the pin in between input terminal and GND is recommended also. The capacitor between input terminal and GND takes effect when power supply impedance increases.

### (4) Filter Capacitor $C_{BC}$

Filter capacitor  $C_{BC}$  and built-in resistance formed a low pass filter that reduces the noise that appears in output voltage. In addition, the filter capacitor  $C_{BC}$  also has a soft start function because it limits the rush current of output when it starts. By changing this capacitance value, the rising speed during start up can be changed. The soft start time with 1V setting of  $V_{OUT}$  and 1 $\mu$ F of  $C_{BC}$  is 9ms (Typ). Select the capacity of 0.01 $\mu$ F to 10 $\mu$ F as an aim. Recommended value is 1 $\mu$ F.

I/O Equivalence Circuits

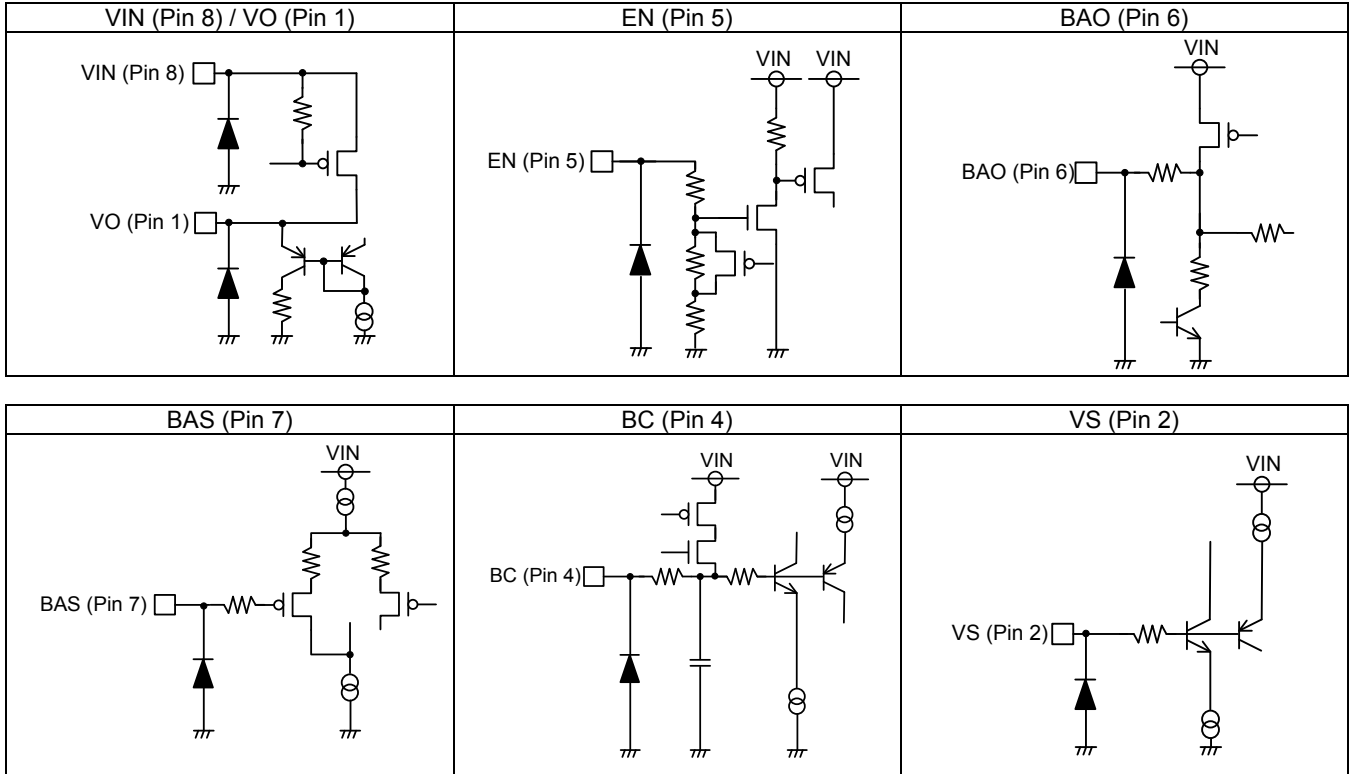
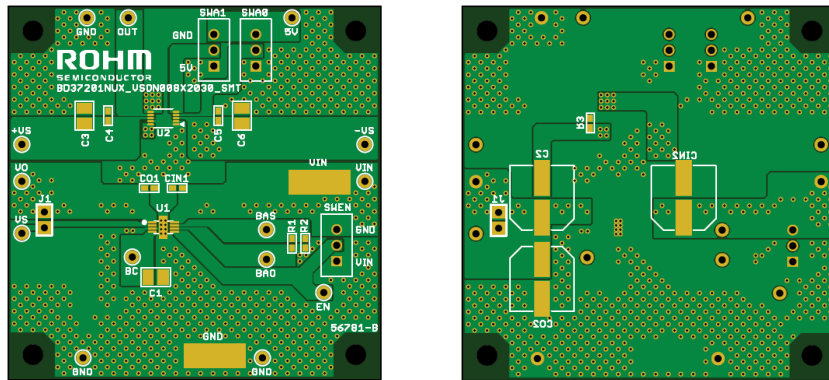

Figure 27. I/O Equivalence Circuits

PCB Layout example



TOP  
BOTTOM  
(board size 60mm x 60mm, board thickness 16mm, material FR-4)

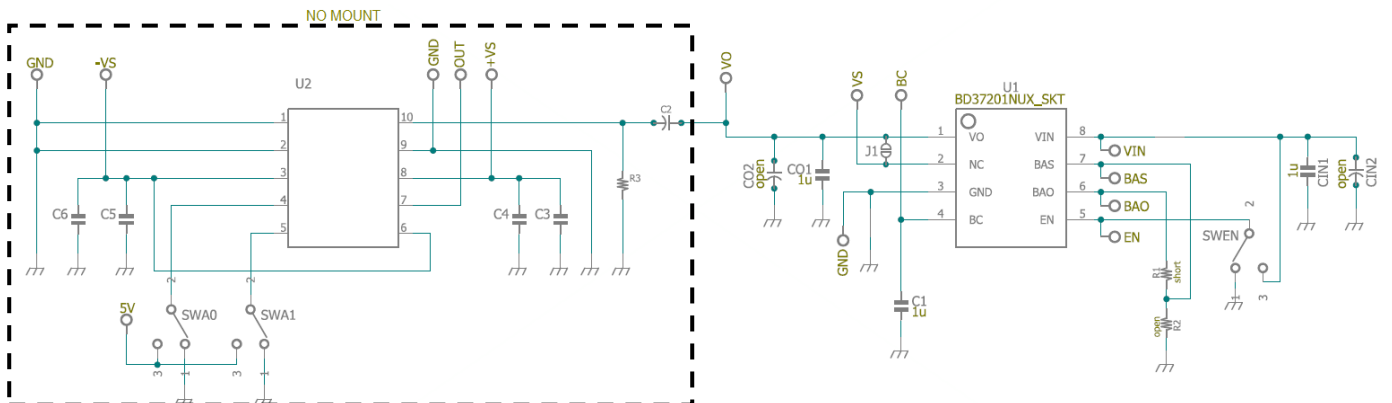

Figure 28. Circuit diagram of evaluation board

(Note) This PCB Layout example includes the test pattern also. This IC position is U1.

## Operational Notes

### 1. Reverse Connection of Power Supply

Connecting the power supply in reverse polarity can damage the IC. Take precautions against reverse polarity when connecting the power supply, such as mounting an external diode between the power supply and the IC's power supply terminals.

### 2. Power Supply Lines

Design the PCB layout pattern to provide low impedance supply lines. Separate the ground and supply lines of the digital and analog blocks to prevent noise in the ground and supply lines of the digital block from affecting the analog block. Furthermore, connect a capacitor to ground at all power supply pins. Consider the effect of temperature and aging on the capacitance value when using electrolytic capacitors.

### 3. Ground Voltage

Ensure that no pins are at a voltage below that of the ground pin at any time, even during transient condition.

### 4. Ground Wiring Pattern

When using both small-signal and large-current ground traces, the two ground traces should be routed separately but connected to a single ground at the reference point of the application board to avoid fluctuations in the small-signal ground caused by large currents. Also ensure that the ground traces of external components do not cause variations on the ground voltage. The ground lines must be as short and thick as possible to reduce line impedance.

### 5. Thermal Consideration

Should by any chance the power dissipation rating be exceeded, the rise in temperature of the chip may result in deterioration of the properties of the chip. The absolute maximum rating of the Pd stated in this specification is when the IC is mounted on a 70mm x 70mm x 1.6mm glass epoxy board. In case of exceeding this absolute maximum rating, increase the board size and copper area to prevent exceeding the Pd rating.

### 6. Recommended Operating Conditions

These conditions represent a range within which the expected characteristics of the IC can be approximately obtained. The electrical characteristics are guaranteed under the conditions of each parameter.

### 7. Inrush Current

When power is first supplied to the IC, it is possible that the internal logic may be unstable and inrush current may flow instantaneously due to the internal powering sequence and delays, especially if the IC has more than one power supply. Therefore, give special consideration to power coupling capacitance, power wiring, width of ground wiring, and routing of connections.

### 8. Operation Under Strong Electromagnetic Field

Operating the IC in the presence of a strong electromagnetic field may cause the IC to malfunction.

### 9. Testing on Application Boards

When testing the IC on an application board, connecting a capacitor directly to a low-impedance output pin may subject the IC to stress. Always discharge capacitors completely after each process or step. The IC's power supply should always be turned OFF completely before connecting or removing it from the test setup during the inspection process. To prevent damage from static discharge, ground the IC during assembly and use similar precautions during transport and storage.

### 10. Inter-pin Short and Mounting Errors

Ensure that the direction and position are correct when mounting the IC on the PCB. Incorrect mounting may result in damaging the IC. Avoid nearby pins being shorted to each other especially to ground, power supply and output pin. Inter-pin shorts could be due to many reasons such as metal particles, water droplets (in very humid environment) and unintentional solder bridge deposited in between pins during assembly to name a few.

### 11. Unused Input Terminals

Input terminals of an IC are often connected to the gate of a MOS transistor. The gate has extremely high impedance and extremely low capacitance. If left unconnected, the electric field from the outside can easily charge it. The small charge acquired in this way is enough to produce a significant effect on the conduction through the transistor and cause unexpected operation of the IC. So unless otherwise specified, unused input terminals should be connected to the power supply or ground line.

## Operational Notes – continued

**12. Regarding Input Pins of the IC**

This monolithic IC contains P<sup>+</sup> isolation and P substrate layers between adjacent elements in order to keep them isolated. P-N junctions are formed at the intersection of the P layers with the N layers of other elements, creating a parasitic diode or transistor. For example (refer to figure below):

When GND > Pin A and GND > Pin B, the P-N junction operates as a parasitic diode.  
When GND > Pin B, the P-N junction operates as a parasitic transistor.

Parasitic diodes inevitably occur in the structure of the IC. The operation of parasitic diodes can result in mutual interference among circuits, operational faults, or physical damage. Therefore, conditions that cause these diodes to operate, such as applying a voltage lower than the GND voltage to an input pin (and thus to the P substrate) should be avoided.

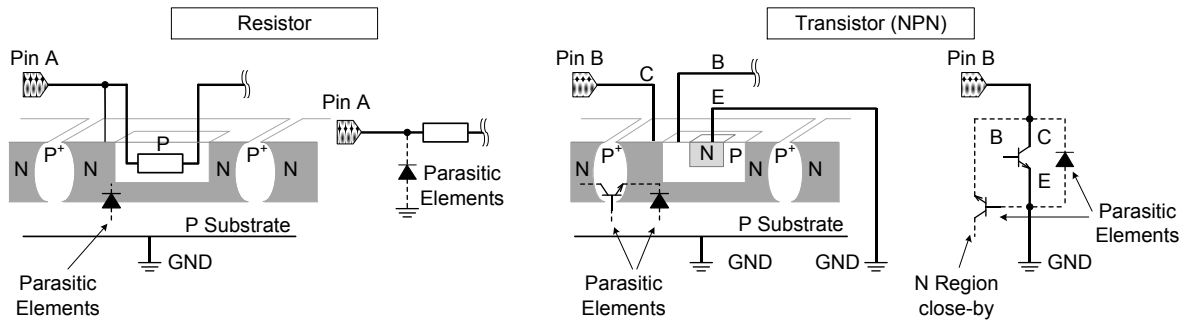

Figure 29. Example of Monolithic IC Structure

**13. Ceramic Capacitor**

When using a ceramic capacitor, determine the dielectric constant considering the change of capacitance with temperature and the decrease in nominal capacitance due to DC bias and others.

**14. Area of Safe Operation (ASO)**

Operate the IC such that the output voltage, output current, and power dissipation are all within the Area of Safe Operation (ASO).

**15. Thermal Shutdown Circuit (TSD)**

This IC has a built-in thermal shutdown circuit that prevents heat damage to the IC. Normal operation should always be within the IC's power dissipation rating. If however the rating is exceeded for a continued period, the junction temperature (T<sub>j</sub>) will rise which will activate the TSD circuit that will turn OFF all output pins. When the T<sub>j</sub> falls below the TSD threshold, the circuits are automatically restored to normal operation.

Note that the TSD circuit operates in a situation that exceeds the absolute maximum ratings and therefore, under no circumstances, should the TSD circuit be used in a set design or for any purpose other than protecting the IC from heat damage.

**16. Over Current Protection Circuit (OCP)**

This IC has a built-in over current protection circuit that activates when the output is accidentally shorted. However, it is strongly advised not to subject the IC to prolonged shorting of the output.

**17. Light Disturbance**

In a device where a portion of silicon is exposed to light such as in a WL-CSP, IC characteristics may be affected due to photoelectric effect. For this reason, it is recommended to come up with countermeasures that will prevent the chip from being exposed to light.

Ordering Information

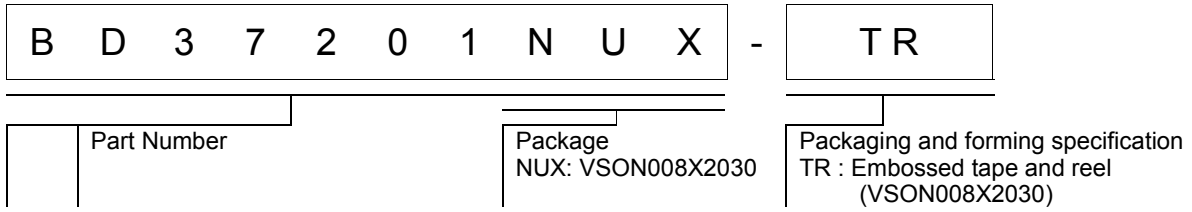

Marking Diagram

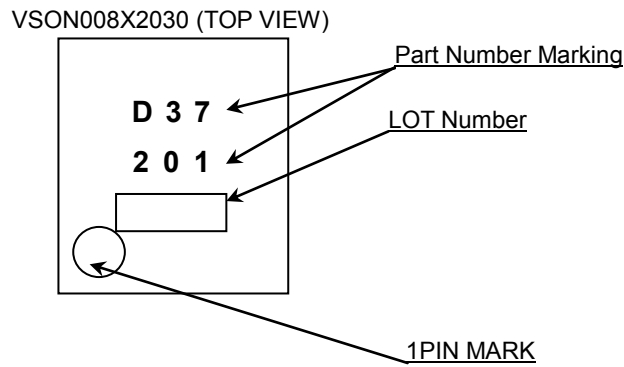

Part Number Marking	Package	Orderable Part Number
D37201	VSON008X2030	BD37201NUX-TR

Physical Dimension Tape and Reel Information

Package Name	VSON008X2030
--------------	--------------

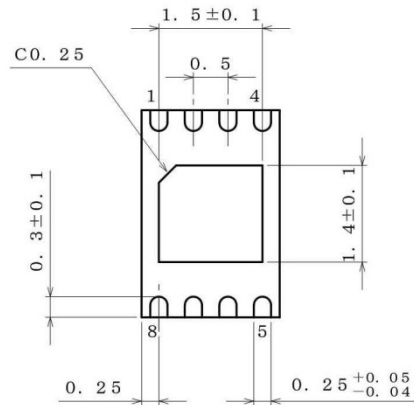
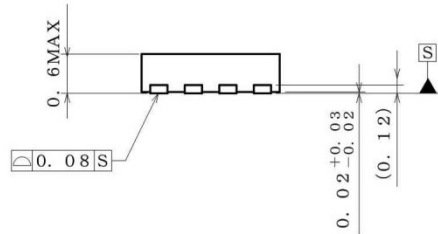
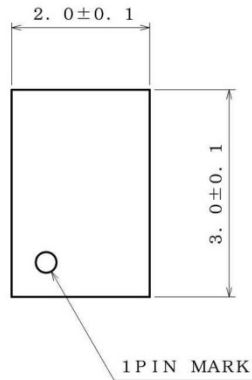

(UNIT : mm)  
 PKG : VSON008X2030  
 Drawing No. EX187-5001

<Tape and Reel information>

Tape	Embossed carrier tape
Quantity	4000pcs
Direction of feed	TR ( The direction is the 1pin of product is at the upper right when you hold reel on the left hand and you pull out the tape on the right hand )

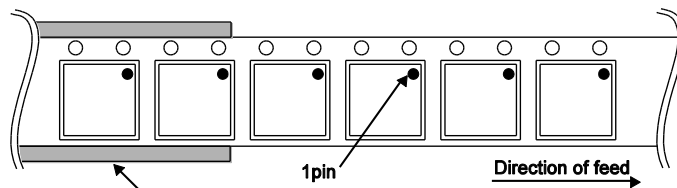

\* Order quantity needs to be multiple of the minimum quantity.

## Revision History

Date	Revision	Changes
18.Apr.2016	001	New Release

# Notice

## Precaution on using ROHM Products

- Our Products are designed and manufactured for application in ordinary electronic equipments (such as AV equipment, OA equipment, telecommunication equipment, home electronic appliances, amusement equipment, etc.). If you intend to use our Products in devices requiring extremely high reliability (such as medical equipment <sup>(Note 1)</sup>, transport equipment, traffic equipment, aircraft/spacecraft, nuclear power controllers, fuel controllers, car equipment including car accessories, safety devices, etc.) and whose malfunction or failure may cause loss of human life, bodily injury or serious damage to property ("Specific Applications"), please consult with the ROHM sales representative in advance. Unless otherwise agreed in writing by ROHM in advance, ROHM shall not be in any way responsible or liable for any damages, expenses or losses incurred by you or third parties arising from the use of any ROHM's Products for Specific Applications.

(Note1) Medical Equipment Classification of the Specific Applications

JAPAN	USA	EU	CHINA
CLASS III	CLASS III	CLASS II b	CLASS III
CLASS IV		CLASS III	

- ROHM designs and manufactures its Products subject to strict quality control system. However, semiconductor products can fail or malfunction at a certain rate. Please be sure to implement, at your own responsibilities, adequate safety measures including but not limited to fail-safe design against the physical injury, damage to any property, which a failure or malfunction of our Products may cause. The following are examples of safety measures:
  - Installation of protection circuits or other protective devices to improve system safety
  - Installation of redundant circuits to reduce the impact of single or multiple circuit failure
- Our Products are designed and manufactured for use under standard conditions and not under any special or extraordinary environments or conditions, as exemplified below. Accordingly, ROHM shall not be in any way responsible or liable for any damages, expenses or losses arising from the use of any ROHM's Products under any special or extraordinary environments or conditions. If you intend to use our Products under any special or extraordinary environments or conditions (as exemplified below), your independent verification and confirmation of product performance, reliability, etc. prior to use, must be necessary:
  - Use of our Products in any types of liquid, including water, oils, chemicals, and organic solvents
  - Use of our Products outdoors or in places where the Products are exposed to direct sunlight or dust
  - Use of our Products in places where the Products are exposed to sea wind or corrosive gases, including Cl<sub>2</sub>, H<sub>2</sub>S, NH<sub>3</sub>, SO<sub>2</sub>, and NO<sub>2</sub>
  - Use of our Products in places where the Products are exposed to static electricity or electromagnetic waves
  - Use of our Products in proximity to heat-producing components, plastic cords, or other flammable items
  - Sealing or coating our Products with resin or other coating materials
  - Use of our Products without cleaning residue of flux (even if you use no-clean type fluxes, cleaning residue of flux is recommended); or Washing our Products by using water or water-soluble cleaning agents for cleaning residue after soldering
  - Use of the Products in places subject to dew condensation
- The Products are not subject to radiation-proof design.
- Please verify and confirm characteristics of the final or mounted products in using the Products.
- In particular, if a transient load (a large amount of load applied in a short period of time, such as pulse. is applied, confirmation of performance characteristics after on-board mounting is strongly recommended. Avoid applying power exceeding normal rated power; exceeding the power rating under steady-state loading condition may negatively affect product performance and reliability.
- De-rate Power Dissipation depending on ambient temperature. When used in sealed area, confirm that it is the use in the range that does not exceed the maximum junction temperature.
- Confirm that operation temperature is within the specified range described in the product specification.
- ROHM shall not be in any way responsible or liable for failure induced under deviant condition from what is defined in this document.

## Precaution for Mounting / Circuit board design

- When a highly active halogenous (chlorine, bromine, etc.) flux is used, the residue of flux may negatively affect product performance and reliability.
- In principle, the reflow soldering method must be used on a surface-mount products, the flow soldering method must be used on a through hole mount products. If the flow soldering method is preferred on a surface-mount products, please consult with the ROHM representative in advance.

For details, please refer to ROHM Mounting specification

### Precautions Regarding Application Examples and External Circuits

1. If change is made to the constant of an external circuit, please allow a sufficient margin considering variations of the characteristics of the Products and external components, including transient characteristics, as well as static characteristics.
2. You agree that application notes, reference designs, and associated data and information contained in this document are presented only as guidance for Products use. Therefore, in case you use such information, you are solely responsible for it and you must exercise your own independent verification and judgment in the use of such information contained in this document. ROHM shall not be in any way responsible or liable for any damages, expenses or losses incurred by you or third parties arising from the use of such information.

### Precaution for Electrostatic

This Product is electrostatic sensitive product, which may be damaged due to electrostatic discharge. Please take proper caution in your manufacturing process and storage so that voltage exceeding the Products maximum rating will not be applied to Products. Please take special care under dry condition (e.g. Grounding of human body / equipment / solder iron, isolation from charged objects, setting of Ionizer, friction prevention and temperature / humidity control).

### Precaution for Storage / Transportation

1. Product performance and soldered connections may deteriorate if the Products are stored in the places where:
  - [a] the Products are exposed to sea winds or corrosive gases, including Cl<sub>2</sub>, H<sub>2</sub>S, NH<sub>3</sub>, SO<sub>2</sub>, and NO<sub>2</sub>
  - [b] the temperature or humidity exceeds those recommended by ROHM
  - [c] the Products are exposed to direct sunshine or condensation
  - [d] the Products are exposed to high Electrostatic
2. Even under ROHM recommended storage condition, solderability of products out of recommended storage time period may be degraded. It is strongly recommended to confirm solderability before using Products of which storage time is exceeding the recommended storage time period.
3. Store / transport cartons in the correct direction, which is indicated on a carton with a symbol. Otherwise bent leads may occur due to excessive stress applied when dropping of a carton.
4. Use Products within the specified time after opening a humidity barrier bag. Baking is required before using Products of which storage time is exceeding the recommended storage time period.

### Precaution for Product Label

A two-dimensional barcode printed on ROHM Products label is for ROHM's internal use only.

### Precaution for Disposition

When disposing Products please dispose them properly using an authorized industry waste company.

### Precaution for Foreign Exchange and Foreign Trade act

Since concerned goods might be fallen under listed items of export control prescribed by Foreign exchange and Foreign trade act, please consult with ROHM in case of export.

### Precaution Regarding Intellectual Property Rights

1. All information and data including but not limited to application example contained in this document is for reference only. ROHM does not warrant that foregoing information or data will not infringe any intellectual property rights or any other rights of any third party regarding such information or data.
2. ROHM shall not have any obligations where the claims, actions or demands arising from the combination of the Products with other articles such as components, circuits, systems or external equipment (including software).
3. No license, expressly or implied, is granted hereby under any intellectual property rights or other rights of ROHM or any third parties with respect to the Products or the information contained in this document. Provided, however, that ROHM will not assert its intellectual property rights or other rights against you or your customers to the extent necessary to manufacture or sell products containing the Products, subject to the terms and conditions herein.

### Other Precaution

1. This document may not be reprinted or reproduced, in whole or in part, without prior written consent of ROHM.
2. The Products may not be disassembled, converted, modified, reproduced or otherwise changed without prior written consent of ROHM.
3. In no event shall you use in any way whatsoever the Products and the related technical information contained in the Products or this document for any military purposes, including but not limited to, the development of mass-destruction weapons.
4. The proper names of companies or products described in this document are trademarks or registered trademarks of ROHM, its affiliated companies or third parties.

**General Precaution**

1. Before you use our Products, you are requested to carefully read this document and fully understand its contents. ROHM shall not be in any way responsible or liable for failure, malfunction or accident arising from the use of any ROHM's Products against warning, caution or note contained in this document.
2. All information contained in this document is current as of the issuing date and subject to change without any prior notice. Before purchasing or using ROHM's Products, please confirm the latest information with a ROHM sales representative.
3. The information contained in this document is provided on an "as is" basis and ROHM does not warrant that all information contained in this document is accurate and/or error-free. ROHM shall not be in any way responsible or liable for any damages, expenses or losses incurred by you or third parties resulting from inaccuracy or errors of or concerning such information.



BD37201NUX - Web Page

Part Number	BD37201NUX
Package	VSON008X2030
Unit Quantity	4000
Minimum Package Quantity	4000
Packing Type	Taping
Constitution Materials List	inquiry
RoHS	Yes