



# MIC2527

## Quad USB Power Control Switch

### Advance Information

### General Description

The MIC2527 is a cost-effective high-side power switch with four independently controlled channels, optimized for self-powered and bus-powered Universal Serial Bus (USB) applications. Few external components are necessary to satisfy USB requirements.

The MIC2527 satisfies the following USB requirements: each switch channel supplies up to 500mA as required by USB downstream devices; the switch's low on-resistance meets USB voltage drop requirements; fault current is limited to typically 750mA, well below the UL 25VA safety requirements; and a flag output is available to indicate fault conditions to the local USB controller. Soft start eliminates the momentary voltage drop on the upstream port that may occur when the switch is enabled in bus-powered applications.

Additional features include thermal shutdown to prevent catastrophic switch failure from high-current loads, undervoltage lockout (UVLO) to ensure that the device remains off unless there is a valid input voltage present, and 3.3V and 5V logic compatible enable inputs.

The MIC2527 is available in active-high and active-low versions in 16-pin DIP and SOIC packages.

### Features

- Compliant to USB specifications
- 4 independent switches
- 3V to 5.5V input
- 500mA minimum continuous load current per port
- 300mΩ maximum on-resistance
- 750mA typical current limit
- Individual open-drain fault flag pins
- 220µA on-state supply current
- 1µA typical off-state supply current
- Output can be forced higher than input (off-state)
- Thermal shutdown
- 2.4V typical undervoltage lockout (UVLO)
- 1ms turn-on (soft-start) and fast turnoff
- Active-high or active-low enable versions
- 16-pin SOIC and DIP packages

### Applications

- USB bus-powered hubs
- USB self-powered hubs
- USB monitors
- USB printers

### Typical Application

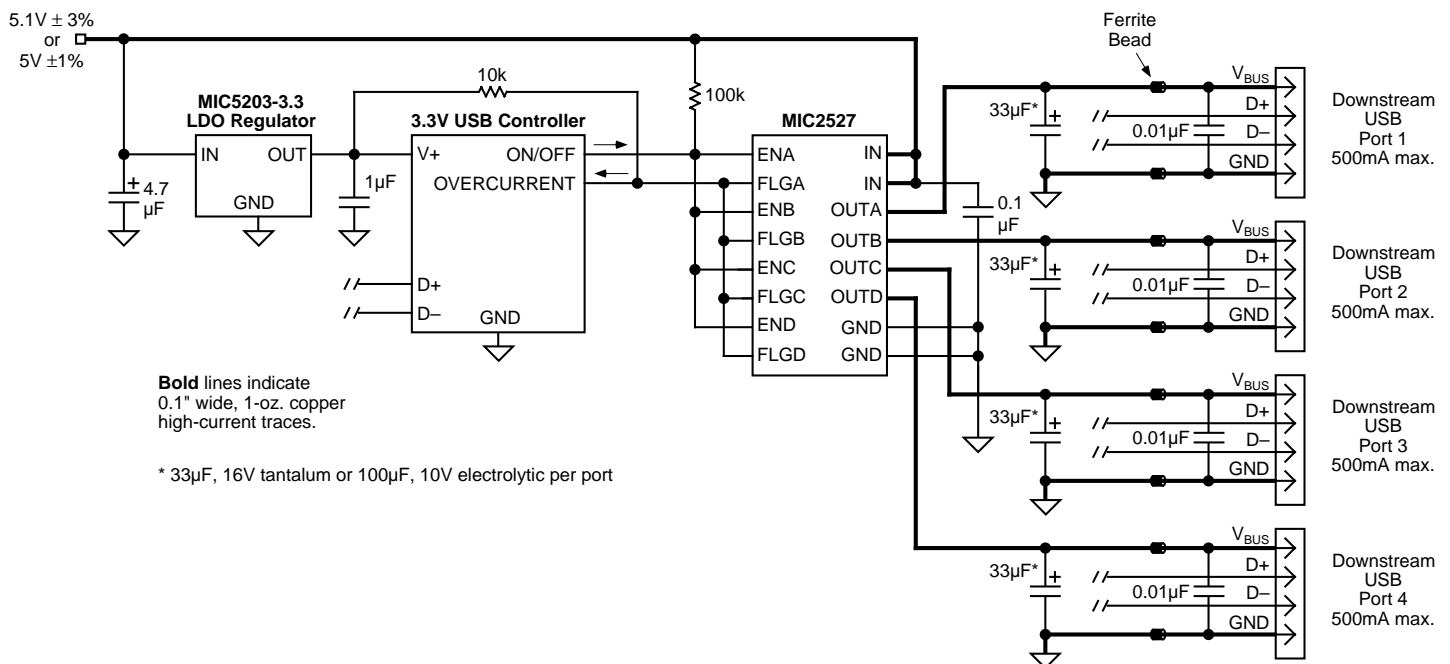

### 4-Port Self-Powered Hub

## Ordering Information

Part Number	Enable	Temperature Range	Package
MIC2527-1BWM	Active High	-40°C to +85°C	16-Pin SOIC
MIC2527-1BN	Active High	-40°C to +85°C	16-pin DIP
MIC2527-2BWM	Active Low	-40°C to +85°C	16-Pin SOIC
MIC2527-2BN	Active Low	-40°C to +85°C	16-pin DIP

## Pin Configuration

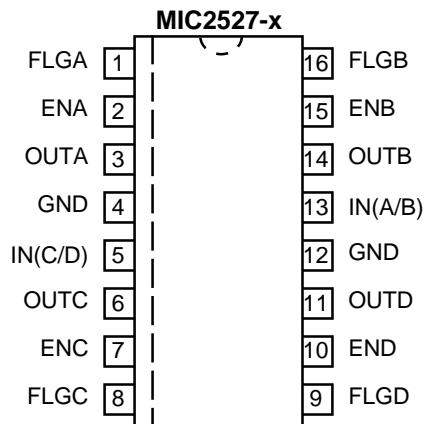

16-Pin SOIC (WM)  
16-Pin DIP (N)

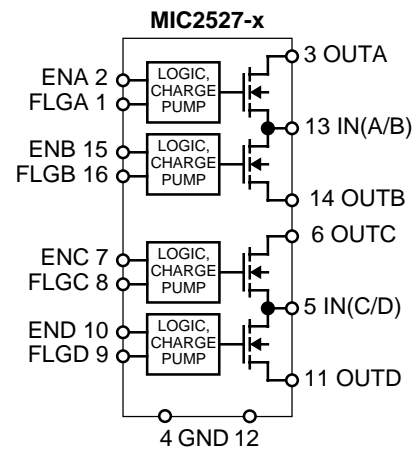

Functional Pinout

## Pin Description

Pin Number	Pin Name	Pin Function
1	FLGA	Flag A (Output): Channel A open-drain fault flag output.
2	ENA	Enable A (Input): Channel A control input.
3	OUTA	Output A: Channel A switch output.
4, 12	GND	Ground: Supply return. Connect both pins to ground.
5	IN(C/D)	Supply Input: Channel C and D switch, logic, and charge-pump supply input.
6	OUTC	Output C: Channel C switch output.
7	ENC	Enable C (Input): Channel C control input.
8	FLGC	Flag C (Output): Channel C open-drain fault flag output.
9	FLGD	Flag D (Output): Channel D open-drain fault flag output.
10	END	Enable D (Input): Channel D control input.
11	OUTD	Output D: Channel D switch output.
13	IN(A/B)	Supply Input: Channel A and B switch, logic, and charge-pump supply input.
14	OUTB	Output B: Channel B switch output.
15	ENB	Enable B (Input): Channel B control input.
16	FLGB	Flag B (Output): Channel B open-drain fault flag output.

## Absolute Maximum Ratings

Supply Voltage ( $V_{IN}$ )	+8.0V
Fault Flag Voltage ( $V_{FLG}$ )	+8.0V
Fault Flag Current ( $I_{FLG}$ )	50mA
Output Voltage ( $V_{OUT}$ )	+8.0V
Output Current ( $I_{OUT}$ )	Internally Limited
Control Input ( $V_{EN}$ )	-0.3V to 12V
Storage Temperature ( $T_S$ )	-65°C to +150°C
Lead Temperature (Soldering 5 sec.)	260°C

## Operating Ratings

Supply Voltage ( $V_{IN}$ )	+3V to +5.5V
Ambient Operating Temperature ( $T_A$ )	-40°C to +85°C
Thermal Resistance	
SOIC ( $\theta_{JA}$ )	120°C/W
DIP( $\theta_{JA}$ )	130°C/W

## Electrical Characteristics

$V_{IN} = +5V$ ;  $T_A = 25^\circ C$ ; unless noted.

Parameter	Condition	Min	Typ	Max	Units
Supply Current	<b>Note 1</b> , switch off, OUT = open		1.5		$\mu A$
	<b>Note 1</b> , all switches on, OUT = open		220		$\mu A$
Enable Input Threshold	low to high transition		2.1	2.4	V
	high to low transition, <b>Note 1</b>	0.8	1.9		V
Enable Input Current	$V_{EN} = V_{OH(min)} = 2.4V$		0.01	1	$\mu A$
	$V_{EN} = V_{OL(max)} = 0.8V$		0.01		$\mu A$
Enable Input Capacitance			1		pF
Switch Resistance	each switch		200		m $\Omega$
Output Turn-On Delay	$R_L = 10\Omega$ each output		0.5		ms
Output Turn-On Rise Time	$R_L = 10\Omega$ each output		1		ms
Output Turnoff Delay	$R_L = 10\Omega$ each output		1		$\mu s$
Output Turnoff Fall Time	$R_L = 10\Omega$ each output		1		$\mu s$
Output Leakage Current	each output				$\mu A$
Short-Circuit Current Limit	each output	0.5	0.75	1.25	A
Overtemperature Shutdown Threshold	$T_J$ increasing		135		$^\circ C$
	$T_J$ decreasing		125		$^\circ C$
Error Flag Output Resistance	$V_{IN} = 5V$ , $I_L = 10mA$		10		$\Omega$
	$V_{IN} = 3.3V$ , $I_L = 10mA$		15		$\Omega$
Error Flag Off Current	$V_{FLAG} = 5V$		0.01		$\mu A$
UVLO Threshold	$V_{IN} =$ increasing		2.5		V
	$V_{IN} =$ decreasing		2.3		V

**General Note:** Devices are ESD protected, however, handling precautions recommended.

**Note 1:** Off is  $\leq 0.8V$  and on is  $\geq 2.4V$  for the MIC2527-1. Off is  $\geq 2.4V$  and on is  $\leq 0.8V$  for the MIC2527-2. The enable input has approximately 200mV of hysteresis. See control threshold charts.

# Typical Characteristics

$V_{IN} = 5V$ ;  $T_A = 25^\circ C$ ; one switch section; unless noted.

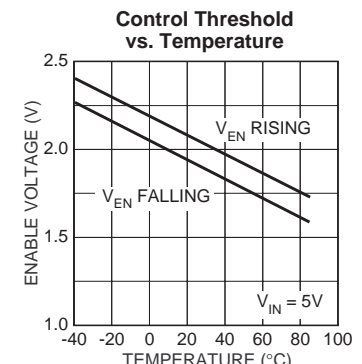
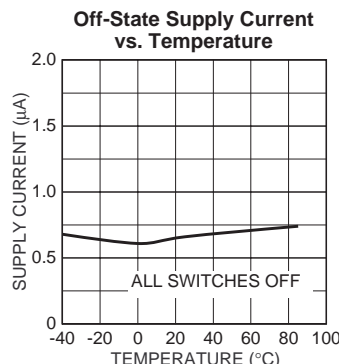
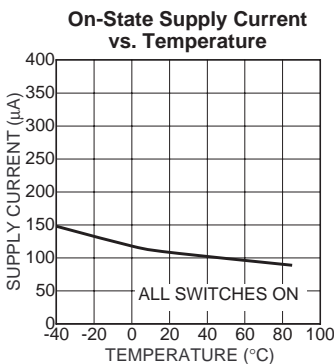
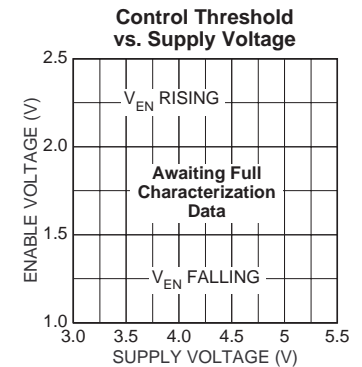
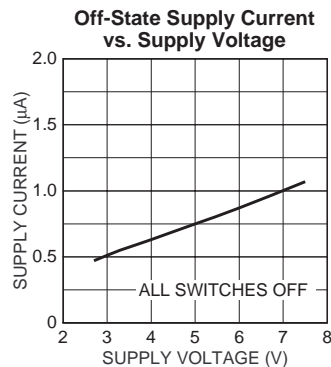
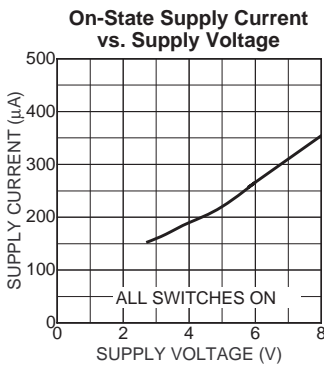
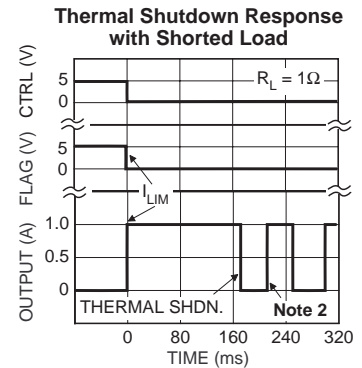
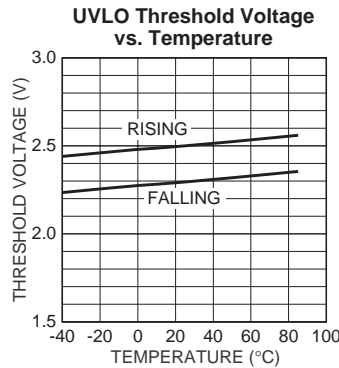
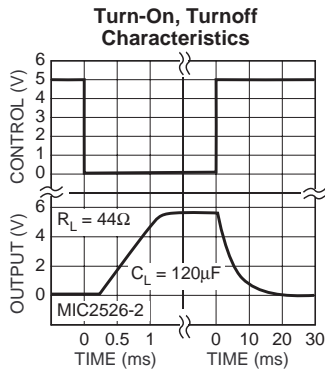
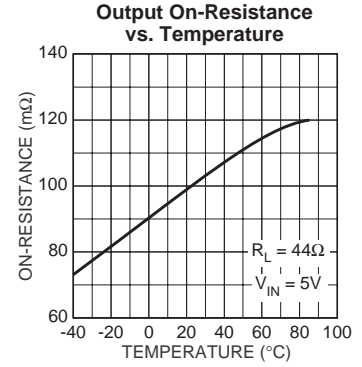
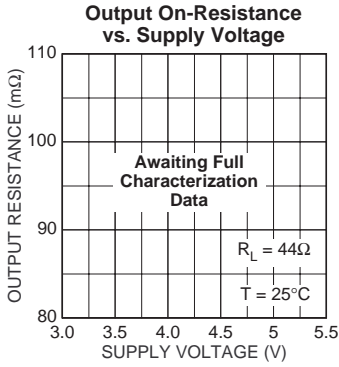
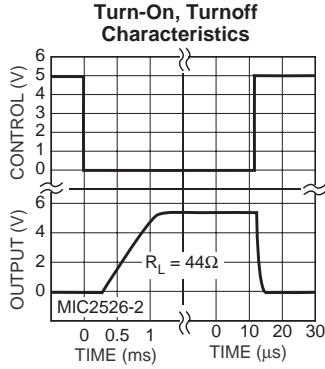

**Note 2:** The on-off cycling beginning at about 170ms is due to temperature sensor hysteresis.

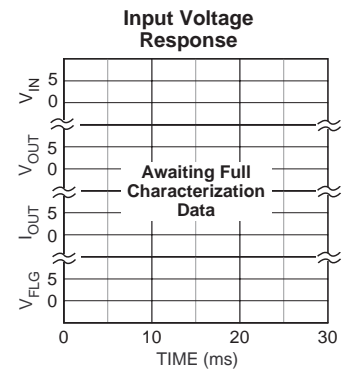
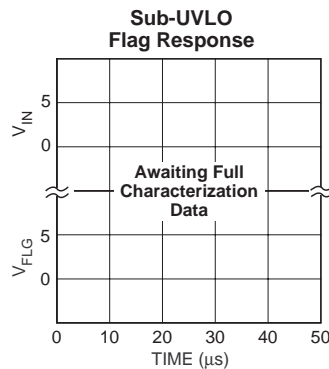
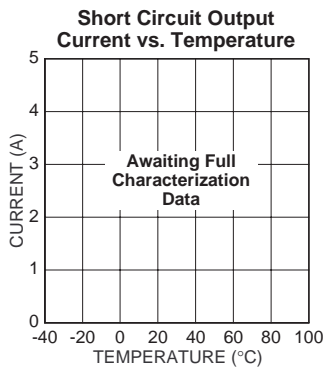
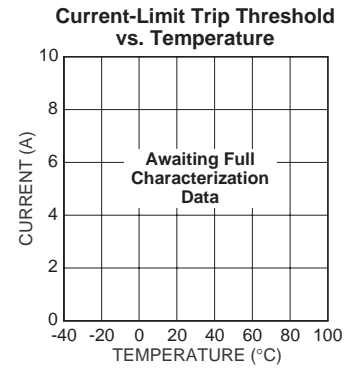
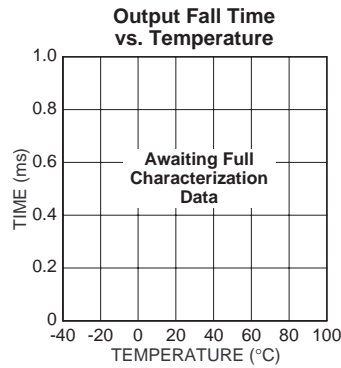
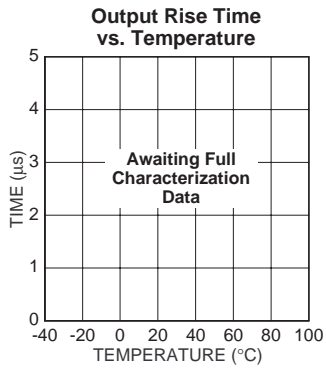
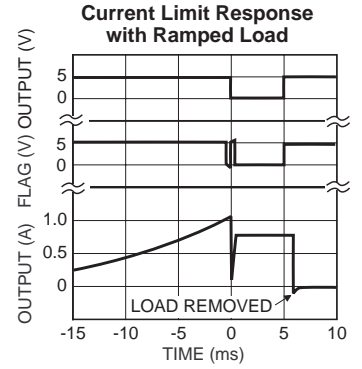
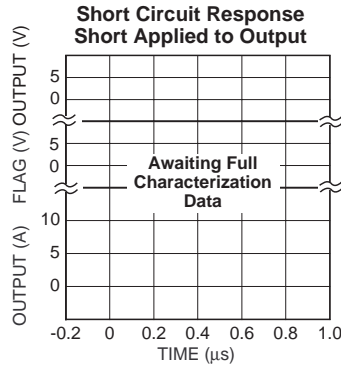
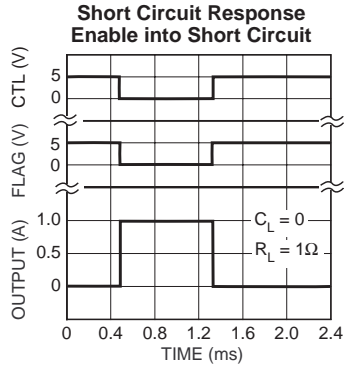

# Block Diagrams

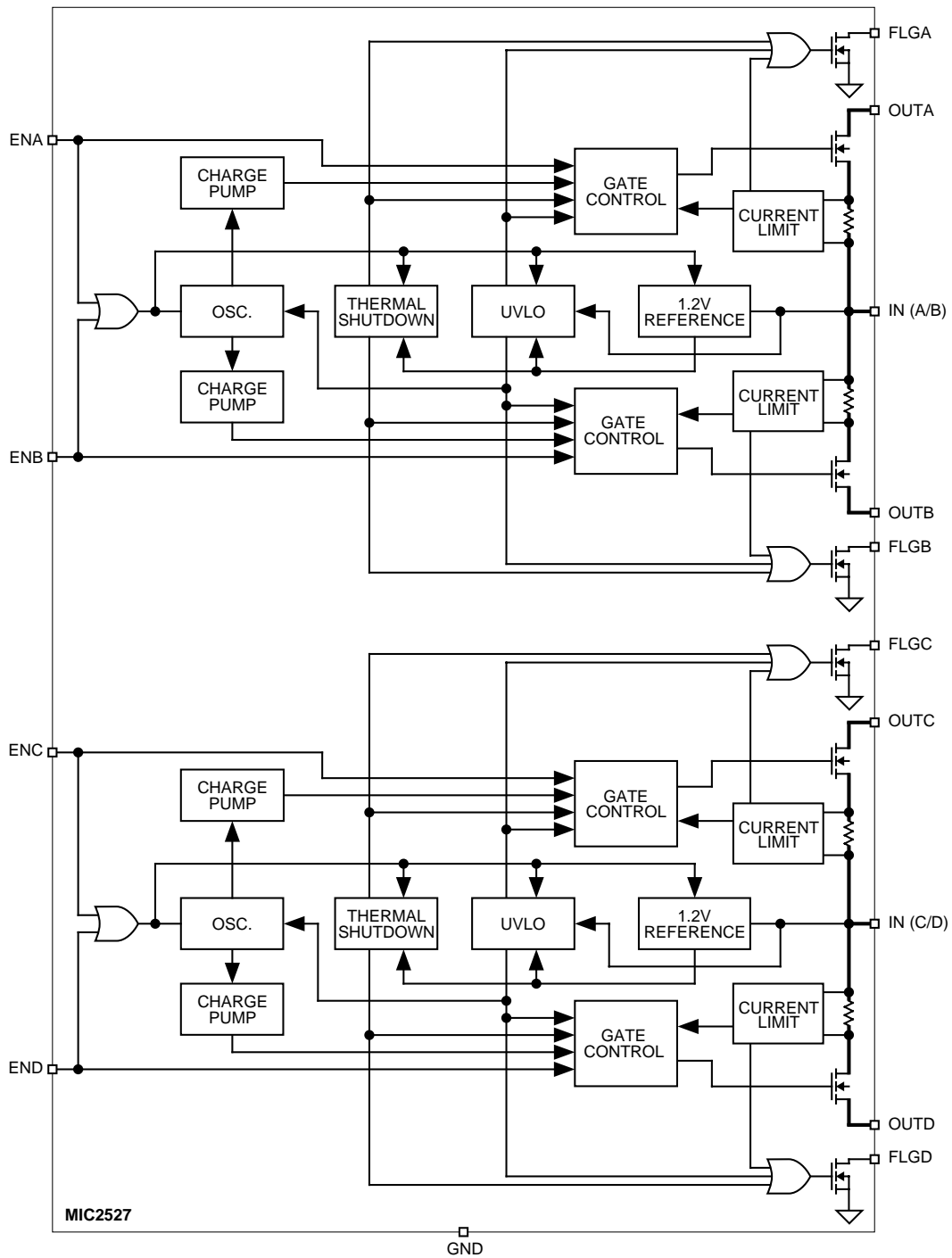

## Functional Description

The MIC2527-1 and MIC2527-2 are quad high-side switches with active-high and active-low enable inputs, respectively. Fault conditions turn off or inhibit turn-on one or both of the output transistors, depending upon the type of fault, and activate the open-drain error flag transistors making them sink current to ground.

### Input and Output

IN (input) is the power supply connection to the logic circuitry and the drain of the output MOSFET. OUTx (output) is the source of its respective MOSFET. In a typical circuit, current flows through the switch from IN to OUT toward the load.

The output MOSFET and driver circuitry are also designed to allow the MOSFET source to be externally forced to a higher voltage than the drain ( $V_{OUT} > V_{IN}$ ) when the output is off. In this situation, the MIC2527 avoids undesirable drain-to-body diode current flow by grounding the body when the switch is off. (The conventional method for optimum turn-on threshold has the source connected to the body. This would allow a large current to flow when  $V_{source} > V_{drain} + 0.6V$ .) If  $V_{IN} < 2.5V$ , UVLO disables both switches. If  $V_{IN} < 2.3V$ , reverse current may flow from OUT to IN regardless of enable state. If OUT is greater than IN when a switch is disabled, current will flow from OUT to IN when the switch is enabled.

### Thermal Shutdown

Thermal shutdown shuts off the affected output MOSFETs and signals all fault flags if the die temperature exceeds 135°C. 10°C of hysteresis prevents the switch from turning on until the die temperature drops to 125°C. Overtemperature detection functions only when at least one switch is enabled.

### Undervoltage Lockout

UVLO (undervoltage lockout) prevents the output MOSFET from turning on until IN (input voltage) exceeds 2.5V typical. In the undervoltage state the FLAG will be low. After the switch turns on, if the voltage drops below 2.3V typical, UVLO shuts off the output MOSFET and signals the fault flag until  $V_{IN}$  drops below 2V. Undervoltage detection functions only when at least one switch is enabled.

## Current Sensing and Limiting

The current-limit threshold is preset internally. The preset level prevents damage to the output MOSFET and external load but allows a minimum current of 0.5A through the output MOSFET of each channel. For further protection, there is typically 150mA foldback in the output current after the current limit threshold is exceeded.

The current-limit circuit senses a portion of the output FET switch current. The current sense resistor shown in the block diagram is virtual, and has no voltage drop. The current limit threshold varies with output voltage, with a 10% to 15% fold back. The reaction to an overcurrent condition varies with three scenarios:

### Switch Enable into Heavy Load

If a switch is powered on or enabled into a heavy load or short-circuit, the switch immediately goes into a constant-current mode, reducing output voltage. The fault flag goes low until the load is reduced or thermal shutdown occurs. See the "Short Circuit Response Enable into Short Circuit" graph.

### Heavy Load Applied Suddenly to Enabled Switch

When a heavy load is applied, a large current may flow from the output capacitor and the switch. The current limit circuit may shut the switch off briefly, then fold back into constant-current mode. The fault flag falls for 10μs to 20μs during the initial current flow, goes inactive for 10μs to 20μs while the switch is off, and then goes low again while the switch is in constant-current mode until the load is reduced or thermal shutdown occurs. See the "Short Circuit Response, Short Applied to Output" graph.

### Gradual Load Increase

If the load current is slowly increased above 500mA, current limiting does not occur until approximately 125% of the short-circuit current limit. Current above this threshold causes the same reaction as a suddenly applied load: the fault flag falls for 10μs to 20μs during the initial current flow, goes inactive for 10μs to 20μs while the switch is off, and then goes low again while the switch is in constant-current mode until the load is reduced or thermal shutdown occurs. See the "Current Limit Response with Ramped Load" graph.

### Fault Flag

FLG is an N-channel, open-drain MOSFET output. The fault-flag is active (low) for one or more of the following conditions: undervoltage (while  $2V < V_{IN} < 2.7$ ), current limit, or thermal shutdown. The flag output MOSFET is capable of sinking a 10mA load to typically 100mV above ground. Multiple FLG pins may be "wire NORed" to a common pullup resistor.

## Applications Information

### Supply Filtering

A  $0.1\mu\text{F}$  to  $1\mu\text{F}$  bypass capacitor from IN to GND, located at the MIC2527, is strongly recommended to control supply transients. Without a bypass capacitor, an output short may cause sufficient ringing on the input (from supply lead inductance) to damage internal control circuitry.

*Input or output transients must not exceed the absolute maximum supply voltage ( $V_{IN\ max} = 8V$ ) even for a short duration.*

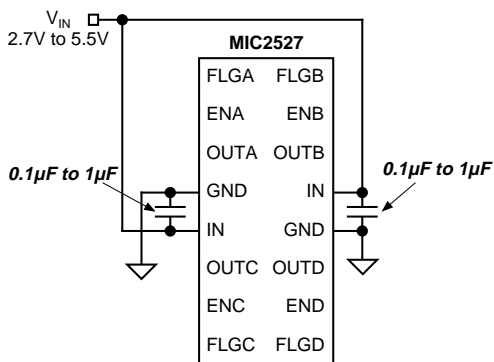

Figure 1. Supply Bypassing

### Enable Input

EN must be driven logic high or logic low for a clearly defined input. Floating the input may cause unpredictable operation. EN should not be allowed to go negative with respect to GND.

### Current Limit Induced Thermal Shutdown

Internal circuitry increases the output MOSFET on-resistance until the series combination of the MOSFET on-resistance and the load impedance limit current to typically 750mA. The increase in power dissipation, in most cases, will cause

the MIC2527 to go into thermal shutdown, disabling affected channels. When this is undesirable, thermal shutdown can be avoided by externally responding to the fault and disabling the current limited channel before the shutdown temperature is reached. The delay between the flag indication of a current limit fault and thermal shutdown will vary with ambient temperature, board layout, and load impedance, but is typically several hundred milliseconds. The USB controller must therefore recognize a fault and disable the appropriate channel within this time.

### Soft Start

The MIC2527 presents a high impedance when off, and slowly becomes a low impedance as it turns on. This reduces inrush current and related voltage drop that results from charging a capacitive load, satisfying the USB voltage droop requirements.

### Transient Overcurrent Filter

The inrush current from the connection of a heavy capacitive load may cause the fault flag to fall for  $10\mu\text{s}$  to  $200\mu\text{s}$  while the switch is in a constant-current mode, charging the capacitance. If needed, a simple 1ms RC low-pass filter in series with the fault flag circuit will prevent erroneous overcurrent reporting (see Figure 2). See *Application Note 17* for suggestions on layout and component selection to minimize transient effects.

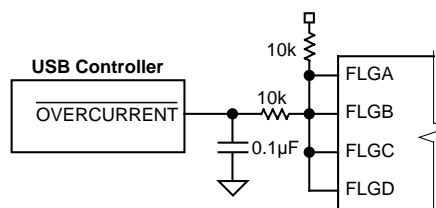
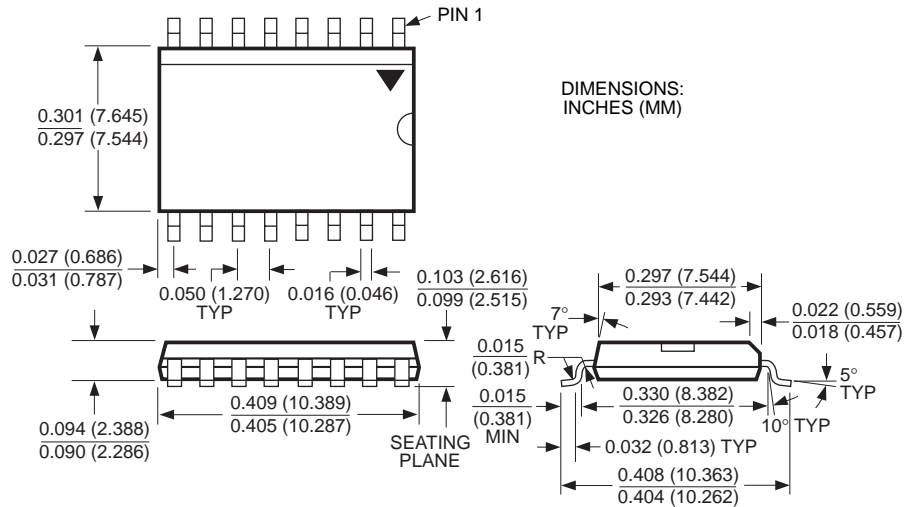

Figure 2. Transient Filter



Package Information



16-Pin Wide SOIC (WM)

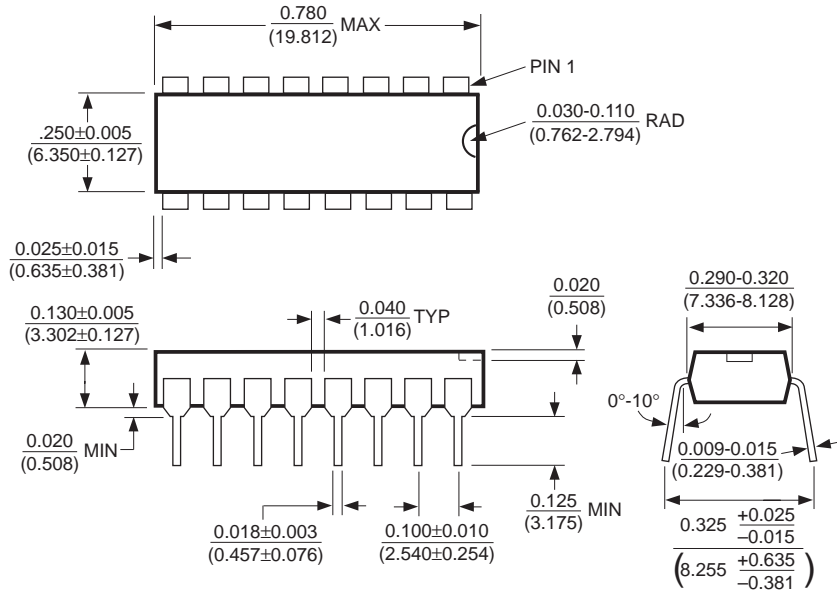

16-Pin Plastic DIP (N)





---

**MICREL INC. 1849 FORTUNE DRIVE SAN JOSE, CA 95131 USA**

TEL + 1 (408) 944-0800 FAX + 1 (408) 944-0970 WEB <http://www.micrel.com>

This information is believed to be accurate and reliable, however no responsibility is assumed by Micrel for its use nor for any infringement of patents or other rights of third parties resulting from its use. No license is granted by implication or otherwise under any patent or patent right of Micrel Inc.

© 1998 Micrel Incorporated