



Actual Size

DMS-EB-RMS

AC-to-RMS Converter Application Board for DMS-30PC/LCD Meters

Purchase on-line at www.datel.com

Features

- Displays true rms values of ac inputs
- $\pm 0.5\%$ accuracy for DMS-30PC-0 or DMS-30LCD-0-5
- $\pm 2\%$ accuracy for DMS-30PC-1 or DMS-30LCD-1-5
- Also works with DMS-40PC/LCD meters (see Ap Note 11)

Functional Specifications

($T_A = +25^\circ\text{C}$, $V_{CC} = +5\text{V}$)

Vac Measurement Range:

$\pm 200\text{mV}$ meters	0 to 199.9Vac
$\pm 2\text{V}$ meters	0 to 750Vac

Conversion Accuracy:

0-200Vac	$\pm 0.5\%$
0-750Vac	$\pm 2\%$

Crest Factors

3, maximum

Input Frequency Range

40Hz to 2kHz

Primary Operating Power

+5V ($\pm 5\%$)

Current Consumption (Board only)

+0.5mA typ., +1mA max.

Operating Temperature Range

0 to $+60^\circ\text{C}$

Storage Temperature Range

-20 to $+75^\circ\text{C}$

Humidity

0 to 95%, non-condensing

Dimensions

2.02" (51.31mm)W x 0.83" (21.08mm)H

Ordering Information

DMS-EB-RMS	AC-to-RMS conversion board
DMS-BZL1	Bezel assembly
DMS-BZL2	Bezel assembly with sealing gasket

Technical Notes

Description: The DMS-EB-RMS board allows the true rms value of ac signals to be displayed on 5V-powered DMS-30PC/LCD digital voltmeters. The meter/board combination has an input range of 0-750Vac with $\pm 2\text{V}$ meters (1Vac resolution) or 0-199.9Vac with $\pm 200\text{mV}$ meters (0.1Vac resolution). A built-in screw-terminal block reliably interfaces signal and power connections. The DMS-EB-RMS now accommodates user-installed modifications such as input-scaling resistors and isolated +5V dc/dc converters.

Power and Safety Precautions: The DMS-EB-RMS's AC HI and AC LOW inputs are not electrically isolated from its 5V supply (AC LOW is connected directly to 5V RETURN). When measuring any input signal which is derived from ac power mains, a dedicated (i.e., it only powers the DMS-EB-RMS), transformer-isolated +5V supply, with a minimum 1kV breakdown rating, **must be used** to power the DMS-EB-RMS board/meter combination. When measuring ac power mains inputs, never connect the DMS-EB-RMS's 5V RETURN to chassis/earth ground anywhere in the system. Failing to follow these instructions could defeat any safety grounding and will place the system +5V power supply, and all its associated circuitry, at dangerously elevated ac-line potentials. In many applications, the DMS-EB-RMS installation is required to meet electrical code requirements. **To ensure safe operation, the DMS-EB-RMS board should only be installed and serviced by technically-qualified personnel.** See DMS Application Note 11 for more details.

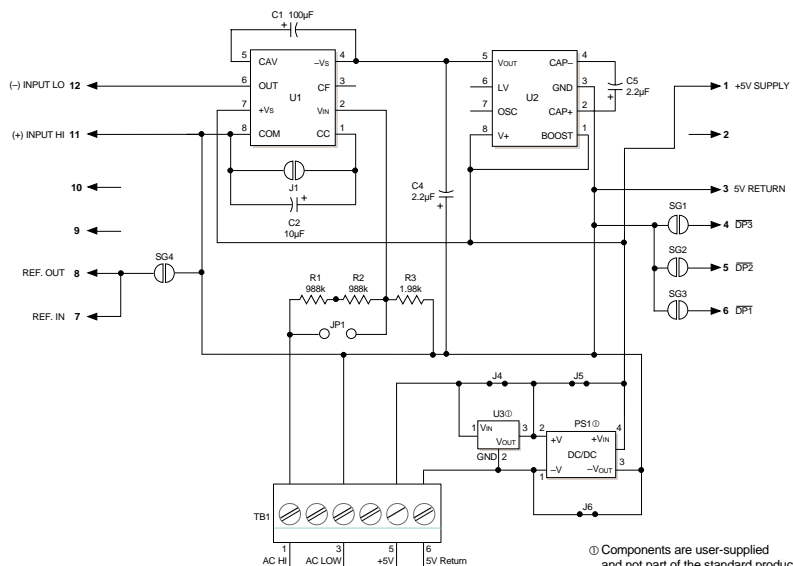
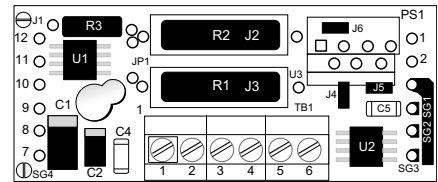

Ⓞ Components are user-supplied and not part of the standard product.

Figure 1. DMS-EB-RMS Schematic Diagram