

HPERC-IBR-HC

*Coldplate Mount System with 3rd Gen Intel® Core™ i7 Processor
and MIL-DTL-38999 High Speed Connectors*

Features

- High speed eSATA, USB 3.0
- VITA 75 coldplate mounting
- Intel® Core™ i7 dual or quad-core Processor
- Soldered DDR3L 8GB, up to 16GB RAM
- Quad Gigabit Ethernet
- Available GPGPU on 16-lane 3rd Generation PCI Express
- Dual independent displays (HDMI/DVI/VGA)
- Simple user expansion and configuration
- Extreme Rugged temperature: -40°C to +85°C
- Tested to MIL-STD-810G and MIL-STD-461F standards;
IP67 rating
- OS support: VxWorks 6.9, Ubuntu, Windows® 7 and WES7



Specifications

• Core System

CPU

Intel® Core™ i7-3517UE 1.7GHz, dual-core
Intel® Core™ i7-3612QE 2.1GHz, quad-core

Chipset

Intel® QM77 Express Chipset

GPGPU

MXM NVIDIA GeForce GT 745M / GTX 950M with 2GB 128-bit GDDR5
(optional)

Memory

16GB DDR3L-1333 ECC
8GB soldered down, 8GB SODIMM

BIOS

AMI EFI

Expansion Busses

MXM (3rd Generation PCIe x16)
PCI/104 Express® Type 2 (PCIe Gen2)
PCI Express Mini Card (PCIe Gen2)

• Standard I/O

Video

2x DVI, 1x HDMI and 1x VGA (only 2 display outputs supported concurrently)

Audio

1x amplified stereo output
1x stereo input

LAN Chipset

4x Intel® I210 Ethernet controller

LAN Speed

10/100/1000 Mbps

eSATA

2x SATA 3Gb/s (non-powered)

USB

2x USB 3.0
4x USB 2.0

Serial

7x RS-232/422

GPIO

8x digital IO

Specifications

● Internal Storage

Removable SATA: 2x 2.5" SLC/MLC SSD on SATA 6 Gb/s (up to 1 TB)

RAID: 0/1 supports up to 12Gb/s

Removable: 1x SDHC - SLC (up to 64 GB)

● Security

TPM

Atmel AT97SC3204-U1A190

Secure Erase

Hardware input triggered

Software triggered

● Power

Input: 10-36VDC

Performance: S-States S3, S4

● Thermal

Internal Transfer

Passive conduction to body

Storage Temperature

-55°C to +85°C

Baseplate Point

Extreme Rugged: -40°C to +85°C (i7-3517UE);

Temperature

-40°C to +80°C (i7-3612QE)

Coldplate conduction

VITA 75.22 mount

● Environmental

Immersion

IEC 529 - IP-67

Salt Spray

RTCA/DO-160G, Section 14, Category S

Altitude

0 to 50K ft.

Humidity

95% at 60°C non-condensing

Shock

MIL-STD-810G - 516.6 Procedures I and V

Vibration

MIL-STD-810G - 514.6 Procedure I

Categories

4, 9, 11, 21

EMI/EMC

MIL-STD-461F

Temperature

MIL-STD-810G - 501.5 Procedure II

MIL-STD-810G - 502.5 Procedure II

● Mechanical

Form Factor

VITA-75.22 Conductive Coldplate

Dimension

223.65(L) x 177.8(W) x 68.7(H) mm (with mounting brackets)

Weight

3.12 kg

IO Connectors

MIL-DTL-38999 (uniquely-keyed)

● Operating System

OS

Ubuntu 16.04

VxWorks 6.9.3.1

Windows® 7 (64-bit)

WES 7 (64-bit/32-bit)

Functional Diagram

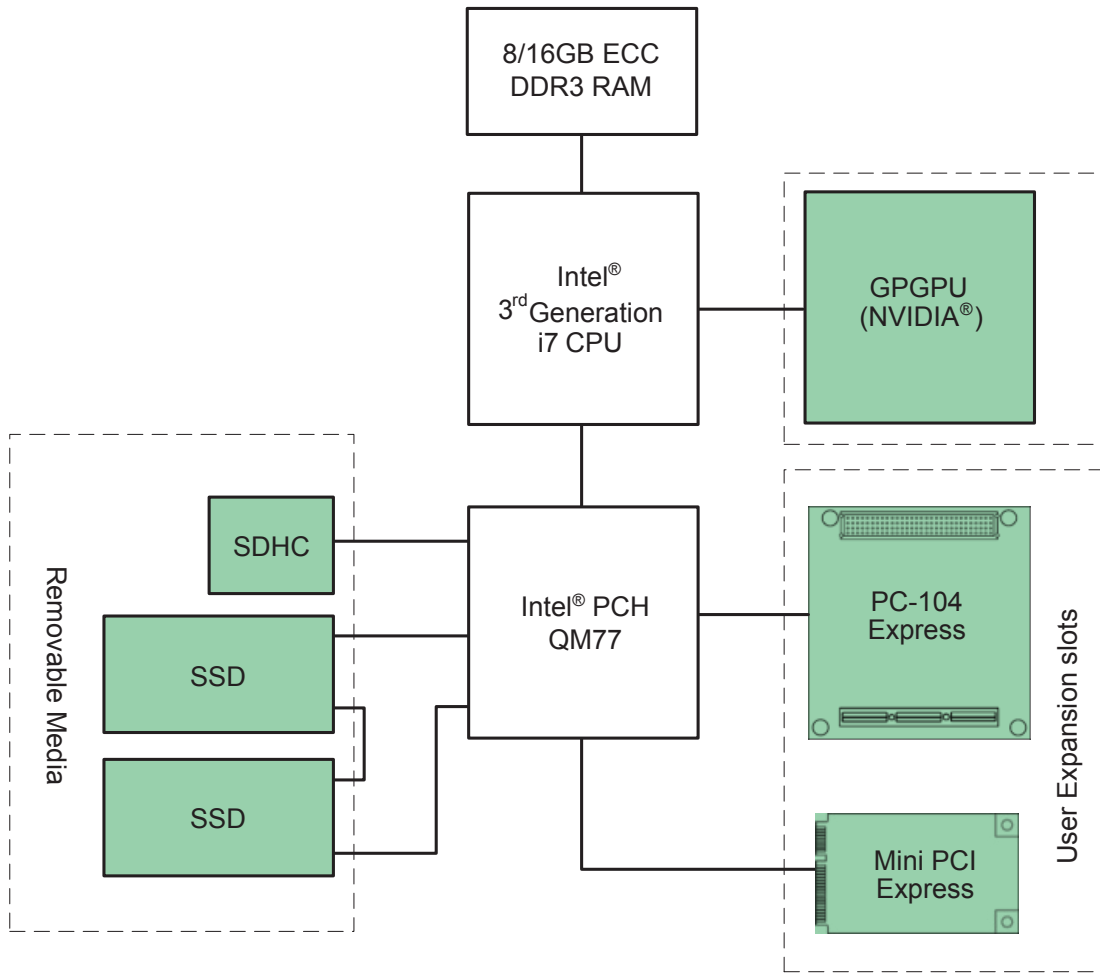

Ordering Information

- **HPERC-IBRHC-100XN**
Coldplate, Intel® Core™ i7 3517UE, 16GB RAM
- **HPERC-IBRHC-B00XN**
Coldplate, Intel® Core™ i7 3517UE, 8GB RAM
- **HPERC-IBRHC-300XN**
Coldplate, Intel® Core™ i7 3612QE, 16GB RAM
- **HPERC-IBRHC-D00XN**
Coldplate, Intel® Core™ i7 3612QE, 8GB RAM

HPERC Accessories

- **HPERC-H-03**
HPERC™ breakout cable kit including MERITEC MIL-STD Nkey & Akey I/O cables, and AC adapter
- **M3N745M-JN-A**
MXM NVIDIA GeForce GT 745M GPU card, with 2GB 128-bit GDDR5 memory (must be pre-assembled at ADLINK factory)
- **M3N950M-JN1A-A**
MXM NVIDIA GeForce GTX 950M GPU card, with 2GB 128-bit GDDR5 memory (must be pre-assembled at ADLINK factory)