

PLEASE CHECK WWW.MOLEX.COM FOR LATEST PART INFORMATION

Part Number: [0190030024](#)
Status: **Active**
Description: InsulKrimp™ Quick Disconnect, Female, for 18-22 (0.80-0.35), Box, Tab 2.79mm (.110") x 0.51mm (.020")

Documents:

[Drawing \(PDF\)](#) [RoHS Certificate of Compliance \(PDF\)](#)
[Product Specification PS-19902-008 \(PDF\)](#)

Agency Certification

CSA LR18689
 UL E79133

General

Product Family Quick Disconnects
 Series [19003](#)
 Comments Funnel Entry
 Crimp Quality Equipment Yes
 Product Name InsulKrimp™
 Type Quick Disconnect

Physical

Barrel Type Closed
 Color - Resin Natural
 Flammability 94V-2
 Gender Female
 Glow-Wire Compliant No
 Insulation Nylon (PA)
 Lock to Mating Part None
 Material - Metal Brass
 Material - Plating Mating Tin
 Material - Plating Termination Tin
 Material - Resin Nylon
 Orientation Straight
 Packaging Type Bag
 Plating min: Mating (µin) 160
 Plating min: Mating (µm) 4
 Plating min: Termination (µin) 160
 Plating min: Termination (µm) 4
 Polarized to Mating Part No
 Tab Thickness 0.51mm (.020")
 Tab Width 2.79mm (.110")
 Temperature Range - Operating -65°C to +105°C
 Termination Interface: Style Crimp or Compression
 Wire Insulation Diameter 3.43mm (.135") max.
 Wire Size AWG 18, 20, 22
 Wire Size mm² 0.35 - 0.80

Electrical

Voltage - Maximum 600V

Material Info

Old Part Number AA-2204

Reference - Drawing Numbers

Product Specification PS-19902-008
 Sales Drawing SD-19003-005

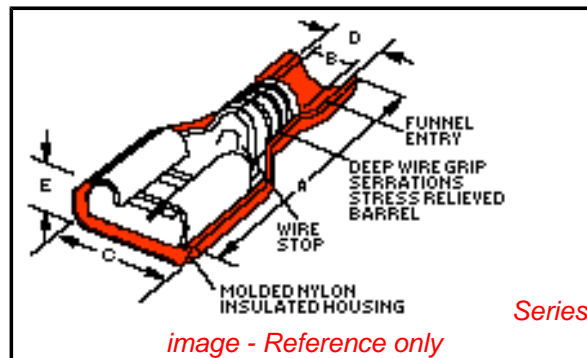

image - Reference only

EU RoHS

ELV and RoHS Compliant

REACH SVHC

Not Reviewed

Halogen-Free

Status

Halogen-Free

China RoHS



Need more information on product environmental compliance?

Email productcompliance@molex.com
 For a multiple part number RoHS Certificate of Compliance, [click here](#)

Please visit the [Contact Us](#) section for any non-product compliance questions.

Search Parts in this Series

[19003Series](#)

Application Tooling | FAQ

Tooling specifications and manuals are found by selecting the products below. Crimp Height Specifications are then contained in the Application Tooling Specification document.

Global

Description	Product #
Hand Crimp Tool	0640010400
Hand Crimp Tool	0640010700
Crimp Head for the AT-200™ Pneumatic Hand Tool	0640050400

This document was generated on 04/13/2010

PLEASE CHECK WWW.MOLEX.COM FOR LATEST PART INFORMATION

10	9	8	7	6	5	4	3	2	19003						
LOOSE PIECE MATERIAL NUMBER	LOOSE PIECE ENGRNG NUMBER	CONTINUOUS STRIP MATERIAL NUMBER	CONTINUOUS STRIP ENGRNG NUMBER	MYLAR TAPE MATERIAL NUMBER	MYLAR TAPE ENGRNG NUMBER	WIRE RANGE AWG	FITS MALE TAB SIZE	INSULATION COLOR	STOCK THICK.	"A" MAX.	"B" MIN.	"C" MAX.	"D" MWID	"E" MAX.	"H" NOMINAL
F 190030071	M-2212	190030106	M-2212C	190030073	M-2212T	26-24	.250x.032 (6.35x0.81)	YELLOW	.016/0.41	.86/21.8	.030/0.76	.38/9.7	.075/1.90	.18/4.6	1.415/35.94
190030064	M-2210	190030103	M-2210C	190030067	M-2210T	26-24	.187x.020 (4.75x0.51)	YELLOW	.016/0.41	.78/19.8	.030/0.76	.32/8.1	.075/1.90	.16/4.1	1.375/34.93
190030068	M-2211	190030104	M-2211C	190030070	M-2211T	26-24	.187x.032 (4.75x0.81)	DK YELLOW	.016/0.41	.78/19.8	.030/0.76	.32/8.1	.075/1.90	.16/4.1	1.375/34.93
190030001	AA-2201	190030105	AA-2201C	190030003	AA-2201T	22-18	.250x.032 (6.35x0.81)	RED	.016/0.41	.86/21.8	.058/1.47	.38/9.7	.135/3.43	.18/4.6	1.415/35.94
190030036	AA-2213	190030109	AA-2213C	190030074	AA-2213T	22-18	.205x.020 (5.21x0.51)	RED	.016/0.41	.78/19.8	.058/1.47	.32/8.1	.135/3.43	.16/4.1	1.375/34.93
190030038	AA-2214	190030110	AA-2214C	190030075	AA-2214T	22-18	.205x.032 (5.21x0.81)	PINK	.016/0.41	.78/19.8	.058/1.47	.32/8.1	.135/3.43	.16/4.1	1.375/34.93
190030011	AA-2202	190030107	AA-2202C	190030013	AA-2202T	22-18	.187x.020 (4.75x0.51)	RED	.016/0.41	.78/19.8	.058/1.47	.32/8.1	.135/3.43	.16/4.1	1.375/34.93
190030017	AA-2203	190030108	AA-2203C	190030020	AA-2203T	22-18	.187x.032 (4.75x0.81)	PINK	.016/0.41	.78/19.8	.058/1.47	.32/8.1	.135/3.43	.16/4.1	1.375/34.93
E 190030024	AA-2204	190030097	AA-2204C	190030026	AA-2204T	22-18	.110x.020 (2.79x0.51)	RED	.012/0.30	.78/19.8	.058/1.47	.23/5.9	.135/3.43	.15/3.8	1.390/35.31
190030030	AA-2205	190030098	AA-2205C	190030032	AA-2205T	22-18	.110x.032 (2.79x0.81)	PINK	.012/0.30	.78/19.8	.058/1.47	.23/5.9	.135/3.43	.15/3.8	1.390/35.31
190030040	BB-2206	190030041	BB-2206C	190030042	BB-2206T	16-14	.250x.032 (6.35x0.81)	BLUE	.016/0.41	.86/21.8	.083/2.10	.38/9.7	.160/4.06	.18/4.6	1.415/35.94
190030062	BB-2215	190030085	BB-2215C	190030077	BB-2215T	16-14	.205x.020 (5.21x0.51)	BLUE	.016/0.41	.78/19.8	.083/2.10	.32/8.1	.160/4.06	.17/4.3	1.405/35.69
190030063	BB-2216	190030086	BB-2216C	190030078	BB-2216T	16-14	.205x.032 (5.21x0.81)	AQUA	.016/0.41	.78/19.8	.083/2.10	.32/8.1	.160/4.06	.17/4.3	1.405/35.69
190030050	BB-2207	190030051	BB-2207C	190030052	BB-2207T	16-14	.187x.020 (4.75x0.51)	BLUE	.016/0.41	.78/19.8	.083/2.10	.32/8.1	.160/4.06	.17/4.3	1.405/35.69
190030056	BB-2208	190030057	BB-2208C	190030058	BB-2208T	16-14	.187x.032 (4.75x0.81)	AQUA	.016/0.41	.78/19.8	.083/2.10	.32/8.1	.160/4.06	.17/4.3	1.405/35.69
196060002	19606-0002	196060001	19606-0001	196060003	19606-0003	12-10	.250x.032 (6.35x0.81)	YELLOW	.018/0.46	1.03/26.1	.120/3.04	.38/9.7	.235/5.97	.22/5.6	1.530/38.86

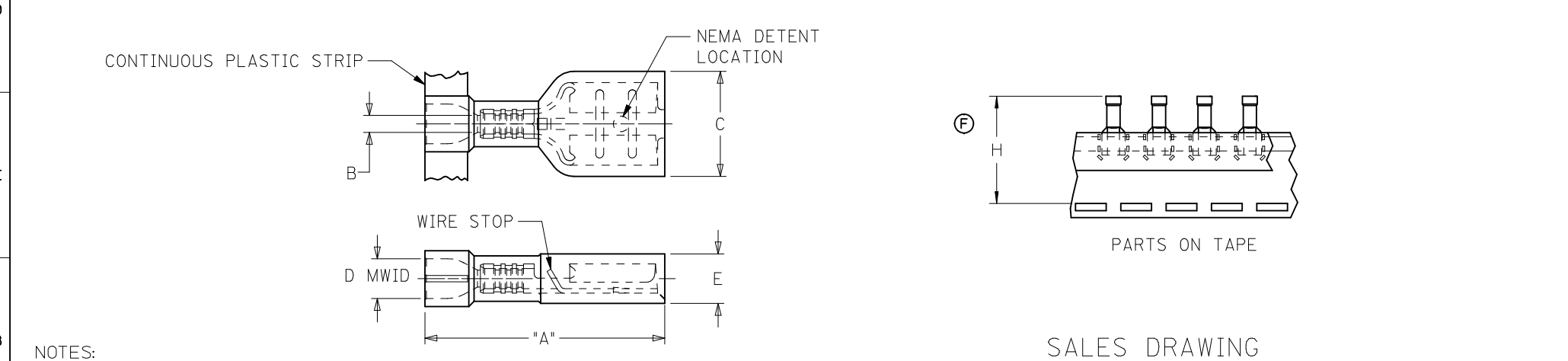

- NOTES:
- MATERIAL: TERMINAL: BRASS
PLATING: ELECTRO-TIN
FERRULE: BRASS
PLATING: ELECTRO-TIN
INSULATION: NYLON 6/6 94V-2.
COLOR: SEE CHART
 - MWID = MAXIMUM WIRE INSULATION DIAMETER
 - PARTS ARE ROHS COMPLIANT.

SALES DRAWING

BB 187 TAPE HTS EC NO: WNA2010-0619 TDR: WNETHRODAHL 2010/04/12 CHKD: JMACNEIL 2010/04/13 APPR: JMACNEIL 2010/06/01 REV	QUALITY SYMBOLS ▽=0 ▽=0	GENERAL TOLERANCES (UNLESS SPECIFIED) mm INCH 4 PLACES ± --- ± --- 3 PLACES ± --- ± --- 2 PLACES ± --- ± --- 1 PLACE ± --- ± --- ANGULAR ± ---°	DIMENSION STYLE IN/MM DRAWN BY DATE BRE 02/03/20 CHECKED BY DATE HEB 02/03/20 APPROVED BY DATE RWD 02/03/20	SCALE --- DESIGN UNITS INCH THIRD ANGLE PROJECTION	TITLE INSULKRIMP FEMALE FIQD STANDARD FLARE
	DRAFT WHERE APPLICABLE MUST REMAIN WITHIN DIMENSIONS		MATERIAL NO. SEE CHART	DOCUMENT NO. SD-19003-005	SHEET NO. 1 OF 1
	THIS DRAWING CONTAINS INFORMATION THAT IS PROPRIETARY TO MOLEX INCORPORATED AND SHOULD NOT BE USED WITHOUT WRITTEN PERMISSION				
	MOLEX INCORPORATED				