

CRYSTAL CONTROLLED OSCILLATORS

3.3V SURFACE MOUNT 5.0 x 7.5mm LVPECL CLOCK OSCILLATOR

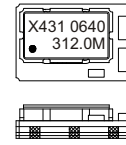

X431

ABSOLUTE MAXIMUM RATINGS

TABLE 1.0

PARAMETER	UNITS	MINIMUM	NOMINAL	MAXIMUM	UNITS	NOTE
Storage Temperature		-55	-	125	°C	
Supply Voltage	(Vcc)	-0.5	-	5.0	Vdc	
Input Voltage		-0.5	-	Vcc+0.5	Vdc	

OPERATING SPECIFICATIONS

TABLE 2.0

PARAMETER		MINIMUM	NOMINAL	MAXIMUM	UNITS	NOTE
Center Frequency	(Fo)	250	-	350	MHz	
Total Frequency Tolerance		-50	-	50	ppm	1
Operating Temperature Range		0	-	85	°C	
Supply Voltage	(Vcc)	3.135	3.3	3.465	Vdc	
Supply Current	(Icc)	-	60	100	mA	
Period Jitter (RMS)		-	3	5	ps RMS	
Period Jitter (peak to peak)		-	20	30	ps pk-pk	
RMS Phase Jitter (BW=12kHz to 20MHz)		-	0.5	1	ps RMS	
SSB Phase Noise at 10Hz offset		-	-40	-	dBc/Hz	
SSB Phase Noise at 100Hz offset		-	-75	-	dBc/Hz	
SSB Phase Noise at 1KHz offset		-	-110	-	dBc/Hz	
SSB Phase Noise at 10KHz offset		-	-135	-	dBc/Hz	
SSB Phase Noise at 100KHz offset		-	-140	-	dBc/Hz	

INPUT CHARACTERISTICS

TABLE 3.0

PARAMETER		MINIMUM	NOMINAL	MAXIMUM	UNITS	NOTE
Disable Input Voltage (Low)	(Vil)	-	-	0.3Vcc	Vdc	2
Enable Input Voltage (High)	(Vih)	0.7Vcc	-	-	Vdc	2
Output Enable Time	(tOE)			2	ms	
Output Disable Time	(tOD)			200	ns	
Standby Current	(Icc)	-	-	30	uA	

LVPECL OUTPUT CHARACTERISTICS

TABLE 4.0

PARAMETER		MINIMUM	NOMINAL	MAXIMUM	UNITS	NOTE
LOAD		-	-	50	Ohms	3
Voltage (High)	(Voh)	2.275	-	-	Vdc	
(Low)	(Vol)	-	-	1.68	Vdc	
Duty Cycle		45	50	55	%	4
Rise / Fall Time 20% to 80%		-	-	0.5	ns	
Start Up Time		-	-	2	ms	

PACKAGE CHARACTERISTICS

TABLE 5.0

Package	Hermetically sealed ceramic package and metal cover.
PROCESS RECOMMENDATIONS	
Soldering Process	See solder profile page 2.

Notes

- Includes initial tolerance, deviation over temperature, supply and load variations, shock, vibration and 20 years aging.
- When the oscillator is disabled, the outputs are at High Impedance. Output is enabled with no connection on pad 1.
- Output must be terminated into 50 ohms to Vcc - 2V or Thevenin equivalent.
- Duty Cycle measured at 50% of output swing.

DESCRIPTION

The Connor Winfield X431 is a fixed frequency, surface mount Crystal Controlled Oscillator (XO) designed for applications requiring low jitter and a +/-50ppm overall frequency stability. Operating at 3.3V supply voltage, the X431 provides LVPECL Differential Outputs with a tri-state enable / disable function.

FEATURES

HIGH FREQUENCY CLOCK

3.3V OPERATION

DIFFERENTIAL LVPECL OUTPUTS

LOW JITTER <1ps RMS

TOTAL FREQUENCY TOLERANCE:
±50ppm

TEMPERATURE RANGE: 0 to 85°C

TRI-STATE ENABLE / DISABLE
FUNCTION

SURFACE MOUNT PACKAGE

TAPE AND REEL PACKAGING

RoHS COMPLIANT / LEAD FREE

ORDERING INFORMATION

X431 - 312.5 MHz

LVPECL
CLOCK
SERIES

CENTER
FREQUENCY

Specifications subject to change without notice.

CRYSTAL CONTROLLED OSCILLATORS

Package Outline and Dimensions

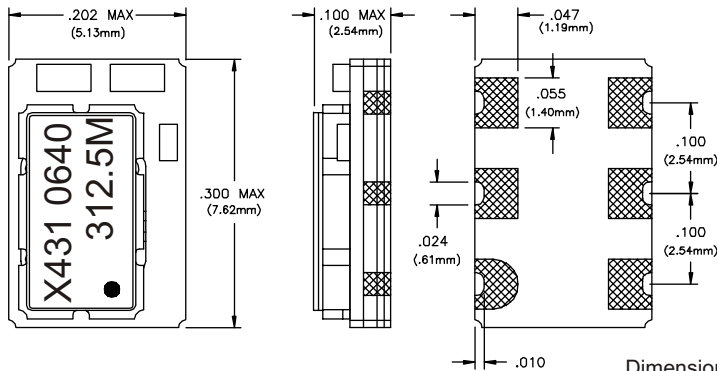

Dimensional Tolerance:
±.005 (.127mm)

Suggested Pad Layout

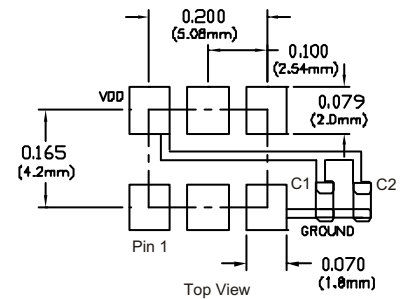

Output Waveform

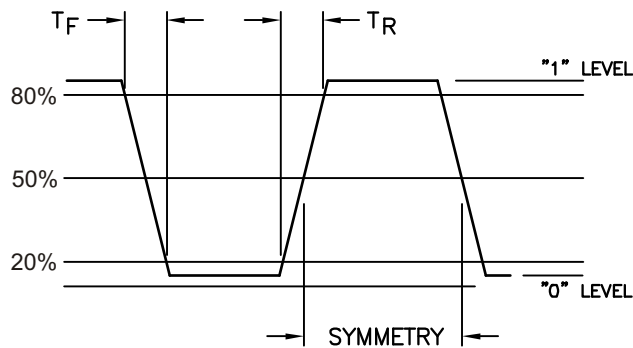

Pin Connections

TABLE 6.0

Pin	Connection
1	Enable / Disable
2	N/C
3	Ground
4	Q Output
5	Q Output
6	Vcc

TABLE 7.0

Enable / Disable Function (Pad 1)	Output
High or Open	Enable
Low	Disable (High Impedance)

Test Circuit

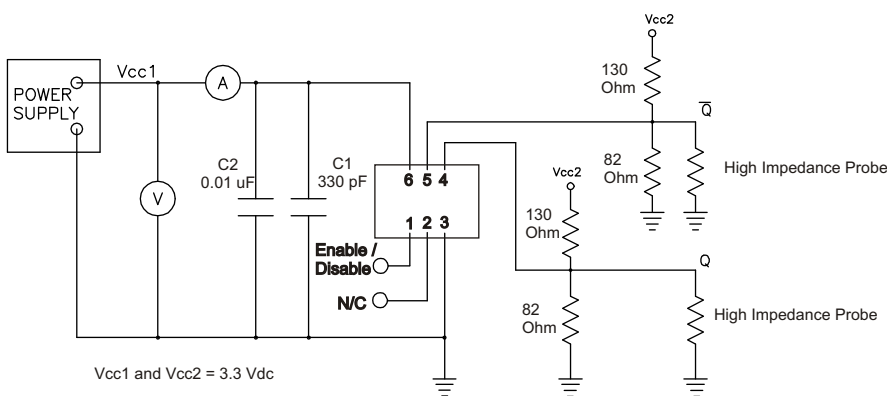

Solder Profile

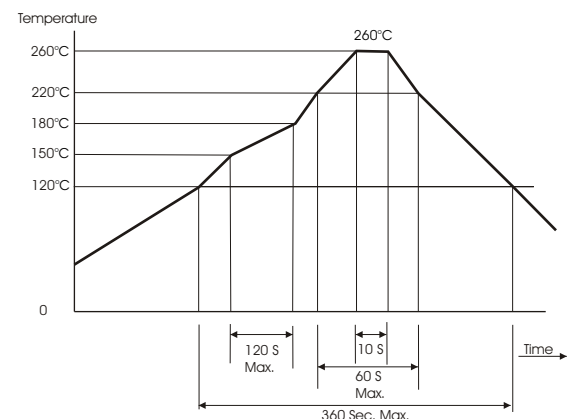

Specifications subject to change without notice.