

13	12	11	10	9	8
MATERIAL NO. ON STRIP	MATERIAL NO. LOOSE PIECE	CABLE SIZE	DIM. "A"	DIM. "B"	USE WITH HOUSING ASSY
1301960315	1301960313	2.5mm ² / 14AWG	3.58/.141	3.94/.155	1302440204
1301960314	1301960310	4.0-6.0mm ² / 12-10AWG	4.90/.193	5.51/.217	1302440202

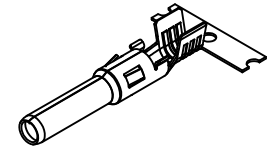

12-10 AWG (4.0-6.0mm²)
SCALE 2:1

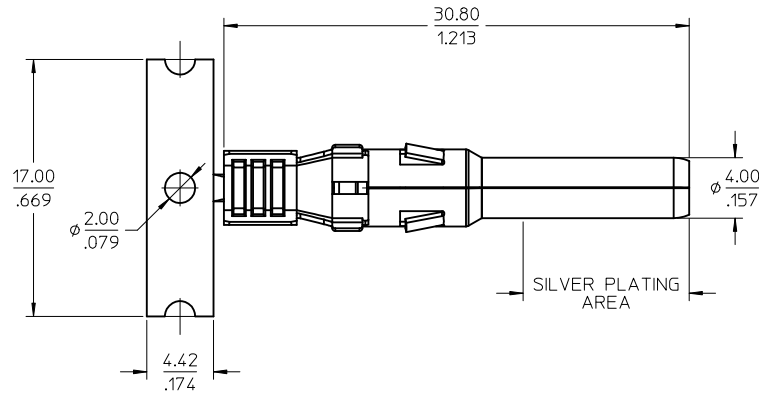
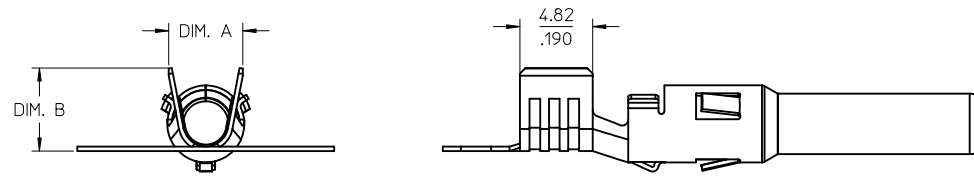

12-10 AWG (4.0-6.0mm²)

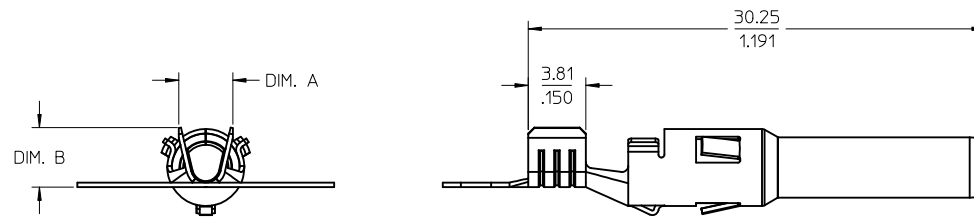

14 AWG (2.5mm²)
SAME AS 12-10 AWG
EXCEPT AS NOTED

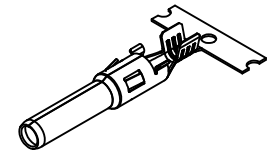

14 AWG (2.5mm²)
SCALE 2:1

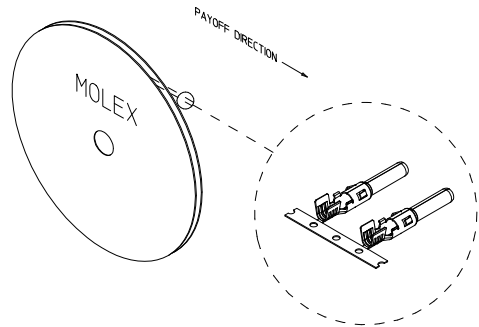

NOTES:

1. MATERIAL: COPPER ALLOY 0.30/.012 THK.
2. FINISH: 2.04MICR/80MINCH MIN. SELECTIVE SILVER OVER 1.27MICR/50MINCH MIN. NICKEL OVERALL
3. TERMINAL FOR USE WITH 130244 SERIES PIN HOUSING ASSEMBLY. SEE CHART FOR APPLICABLE PART NUMBERS.
4. PRODUCT SPECIFICATION: PS-130244-001
5. STRIP TERMINALS ARE REELED AS SHOWN ABOVE ON XXX SIZE REELS, XXX PARTS PER REEL.
6. APPLICATION TOOLING AND CRIMP SPECIFICATIONS: CONSULT FACTORY.
7. PARTS ARE ROHS COMPLIANT.

PRELIMINARY EC NO: WNA2011-0195 DRW: CLYORK 2010/11/24 CHKD: APPR: DTITUS 2011/01/14	QUALITY SYMBOLS ▽=0 ▽=0	GENERAL TOLERANCES (UNLESS SPECIFIED)		DIMENSION STYLE MM/IN	SCALE 4:1	DESIGN UNITS METRIC	THIRD ANGLE PROJECTION				
		4 PLACES ± .005 ± .005	3 PLACES ± .005 ± .010	2 PLACES ± 0.25 ± .02	1 PLACE ± 0.5 ± .---	ANGULAR ± 3 °	DRAWN BY CLYORK	DATE 2010/04/15	CHECKED BY DTITUS	DATE 2010/04/15	APPROVED BY DTITUS
2		DRAFT WHERE APPLICABLE MUST REMAIN WITHIN DIMENSIONS		SEE CHART	MATERIAL NO. DOCUMENT NO.		MATERIAL NO. SD-130196-001	SHEET NO. 1 OF 1			

THIS DRAWING CONTAINS INFORMATION THAT IS PROPRIETARY TO MOLEX INCORPORATED AND SHOULD NOT BE USED WITHOUT WRITTEN PERMISSION