

TR5270M™ LEDs

CxxxTR5270M-Sxx000 (175- μm)

CxxxTR5270M-Sxx000-3 (250- μm)

Data Sheet

Cree's TR5270M LEDs are the next generation of solid-state LED emitters that combine highly efficient InGaN materials with Cree's proprietary device technology and silicon-carbide substrates to deliver superior value for the TV-backlighting and general-illumination markets. The TR5270M LEDs are among the brightest in the top-view market while delivering a low forward voltage, resulting in a very bright and highly efficient solution. The TR5270M is available in two chip thicknesses: 175 μm and 250 μm . The 250- μm -thick version offers 5% improvement brightness over the 175- μm version due the increased bevel area. The metal backside allows for eutectic die attach and enables superior performance from improved thermal management. The design is optimally suited for industry-standard top-view packages.

FEATURES

- Rectangular LED RF Performance
 - 450 nm - 200 mW min
 - 460 nm - 180 mW min
- High Reliability - Eutectic, Solder Paste or Preforms Attach
- Low Forward Voltage - 3.2 V Typical at 120 mA
- Maximum DC Forward Current - 250 mA
- Class 2 ESD Rating
- InGaN Junction on Thermally Conductive SiC Substrate

APPLICATIONS

- Large LCD Backlighting
 - Television
- General Illumination
- Medium LCD Backlighting
 - Portable PCs
 - Monitors
- LED Video Displays
- White LEDs

CxxxTR5270M-Sxx000 (175- μm) Chip Diagram

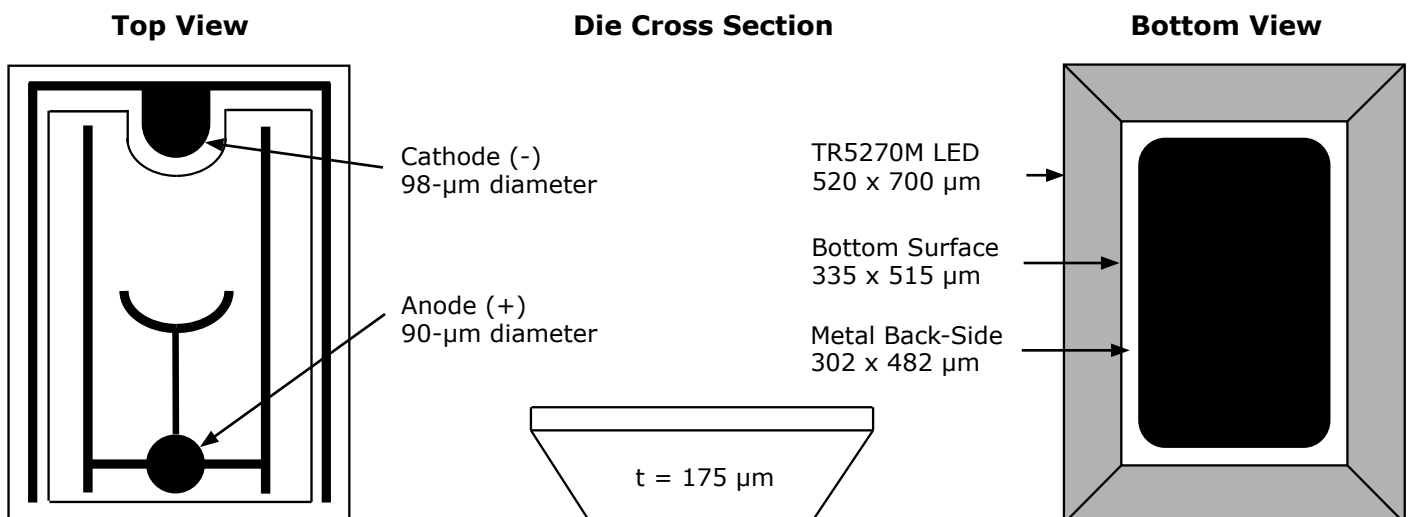

CxxxTR5270M-Sxx000-3 (250- μm) Chip Diagram

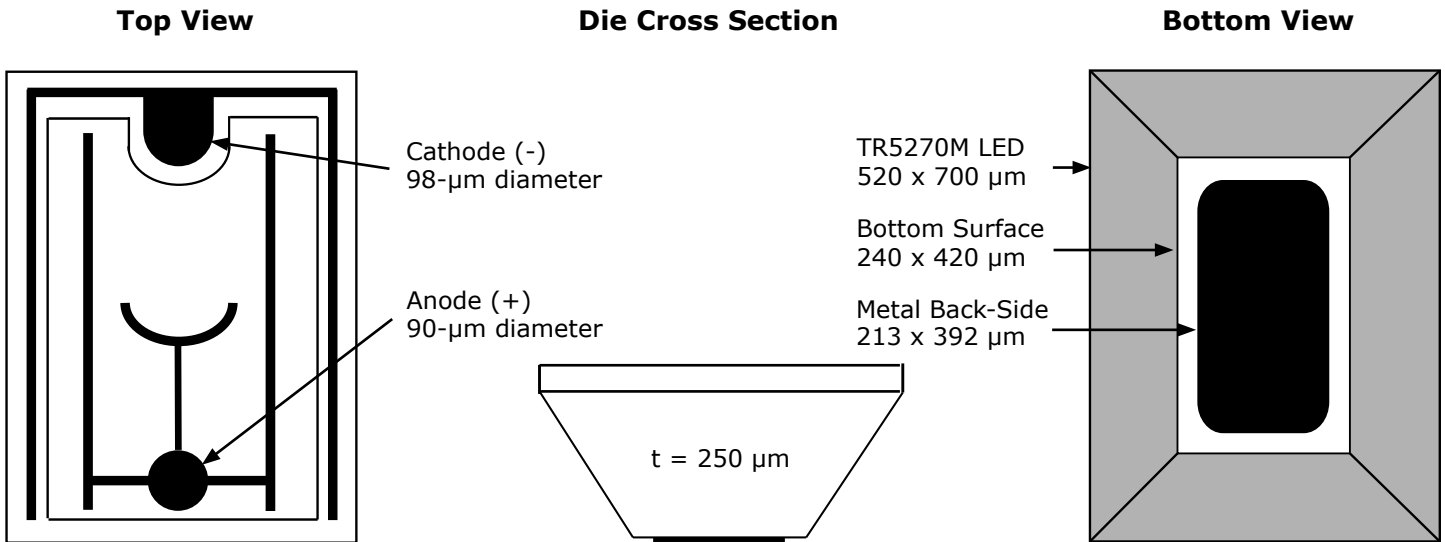

Mechanical Specifications		CxxxTR5270M-Sxx000 (175- μm)	
Description	Dimension	Tolerance	
P-N Junction Area (μm)	446 x 643	± 35	
Chip Area (μm)	520 x 700	± 35	
Chip Thickness (μm)	175	± 15	
Au Bond Pad Diameter Anode (μm)	90	± 10	
Au Bond Pad Thicknesses (μm)	1.0	± 0.5	
Au Bond Pad Diameter Cathode (μm)	98	± 10	
Bottom Area (μm)	335 x 515	± 45	
Bottom Contact Metal (μm)	302 x 482	± 25	
Bottom Contact Metal Thickness (μm)	3.0	± 1.0	

Mechanical Specifications		CxxxTR5270M-Sxx000-3 (250- μm)	
Description	Dimension	Tolerance	
P-N Junction Area (μm)	446 x 643	± 35	
Chip Area (μm)	520 x 700	± 35	
Chip Thickness (μm)	250	± 15	
Au Bond Pad Diameter Anode (μm)	90	± 10	
Au Bond Pad Thicknesses (μm)	1.0	± 0.5	
Au Bond Pad Diameter Cathode (μm)	98	± 10	
Bottom Area (μm)	240 x 420	± 45	
Bottom Contact Metal (μm)	213 x 392	± 25	
Bottom Contact Metal Thickness (μm)	3.0	± 1.0	



Maximum Ratings at $T_A = 25^\circ\text{C}$ <small>Notes 1, 3 & 4</small>		CxxxTR5270M-Sxx00 and CxxxTR5270M-Sxx00-3
DC Forward Current		250 mA
Peak Forward Current (1/10 duty cycle @ 1 kHz)		300 mA
LED Junction Temperature		150°C
Reverse Voltage		5 V
Operating Temperature Range		-40°C to +100°C
Storage Temperature Range		-40°C to +100°C
Electrostatic Discharge Threshold (HBM) <small>Note 2</small>		1000 V
Electrostatic Discharge Classification (MIL-STD-883E) <small>Note 2</small>		Class 2

Typical Electrical/Optical Characteristics at $T_A = 25^\circ\text{C}$, $I_f = 120\text{ mA}$ <small>Note 3</small>					
Part Number	Forward Voltage (V_f , V)			Reverse Current [$I(V_r=5V)$, μA]	Full Width Half Max (λ_p , nm)
	Min.	Typ.	Max.	Max.	Typ.
C450TR5270M-Sxx000	2.7	3.2	3.5	2	20
C460TR5270M-Sxx000	2.7	3.2	3.5	2	21
C450TR5270M-Sxx000-3	2.7	3.2	3.5	2	20
C460TR5270M-Sxx000-3	2.7	3.2	3.5	2	21

Notes:

- Maximum ratings are package-dependent. The above ratings were determined using lamps in chip-on-MCPCB (metal core PCB) packages for characterization. Ratings for other packages may differ. Junction temperature should be characterized in a specific package to determine limitations. Assembly processing temperature must not exceed 325°C (< 5 seconds).
- Product resistance to electrostatic discharge (ESD) according to the HBM is measured by simulating ESD using a rapid avalanche energy test (RAET). The RAET procedures are designed to approximate the maximum ESD ratings shown.
- All products conform to the listed minimum and maximum specifications for electrical and optical characteristics when assembled and operated at 120 mA within the maximum ratings shown above. Efficiency decreases at higher currents. Typical values given are within the range of average values expected by manufacturer in large quantities and are provided for information only. All measurements were made using lamps in T-1 3/4 packages (with Hysol OS4000 epoxy encapsulant and clear epoxy die attach). Optical characteristics measured in an integrating sphere using Illuminance E.
- The maximum forward current is determined by the thermal resistance between the LED junction and ambient. It is crucial for the end-product to be designed in a manner that minimizes the thermal resistance from the LED junction to ambient in order to optimize product performance.

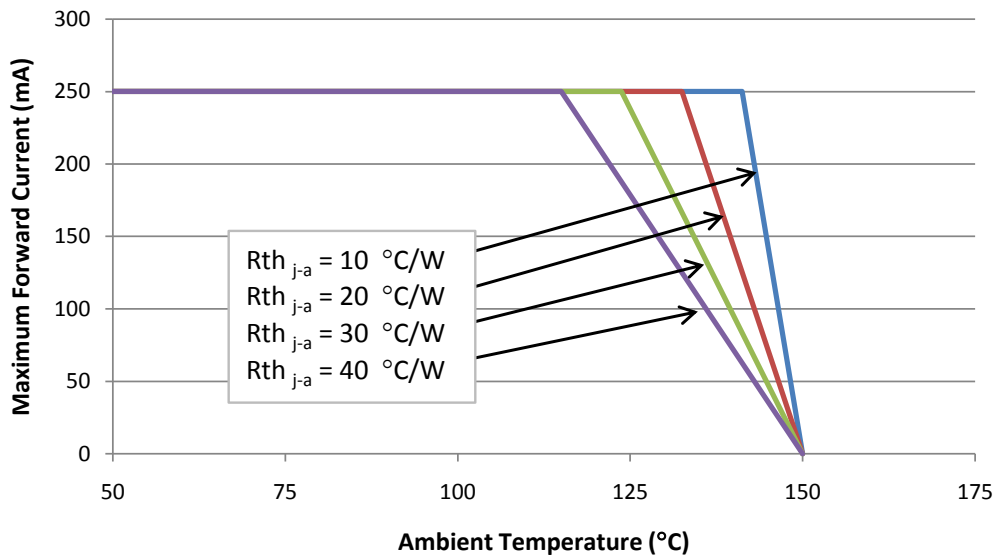



Standard Bins for CxxxTR5270M-Sxx00

LED chips are sorted to the **radiant flux** and **dominant wavelength** bins shown. A sorted die sheet contains die from only one bin. Sorted die kit (CxxxTR5270M-Sxxxxx or CxxxTR5270M-Sxxxxx-3) orders may be filled with any or all bins (CxxxTR5270M-xxxx or CXXXTR5270M-xxxx-3) contained in the kit. All radiant flux and dominant wavelength values shown and specified are at $I_f = 120$ mA.

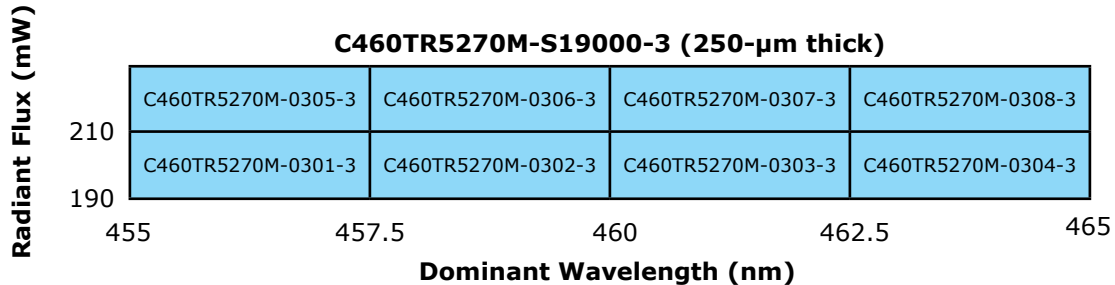
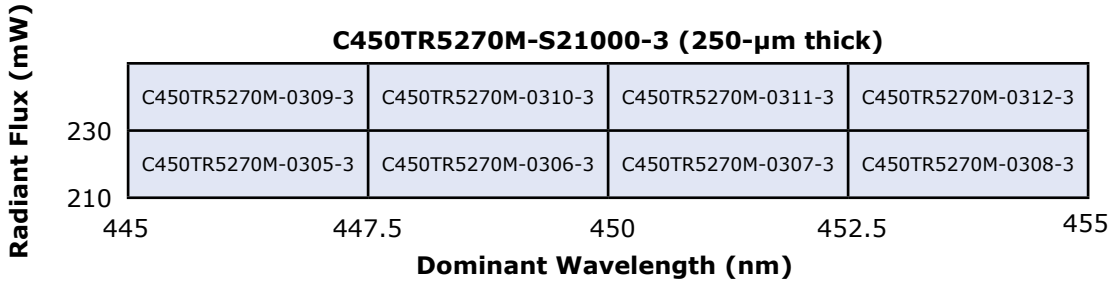
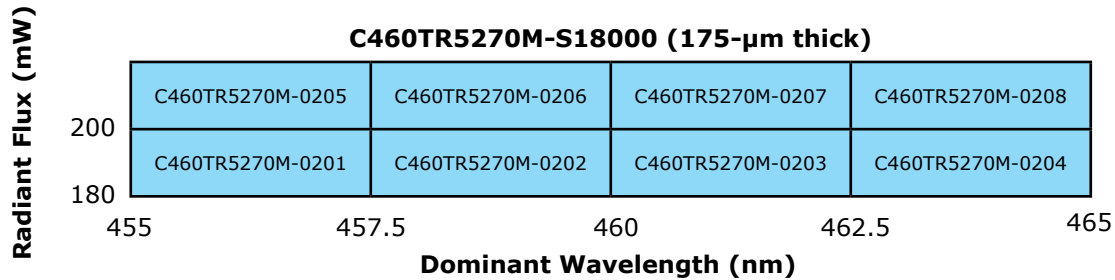
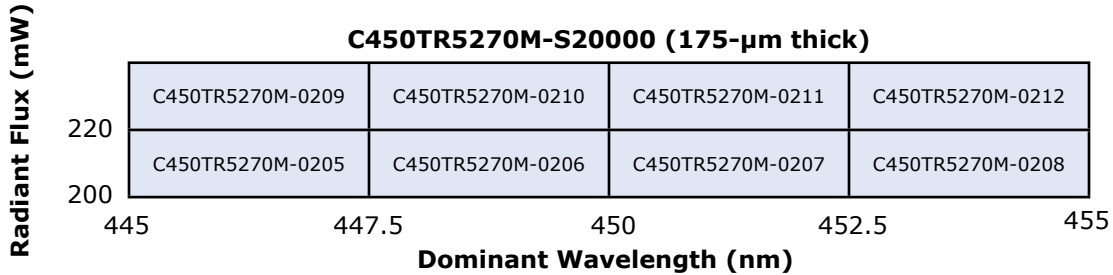

Note: The radiant-flux values above are representative of the die in a Cree 5-mm lamp.



Characteristic Curves

These are representative measurements for the TR5270M LED product. Actual curves will vary slightly for the various radiant flux and dominant wavelength bins.

Forward Current vs Forward Voltage

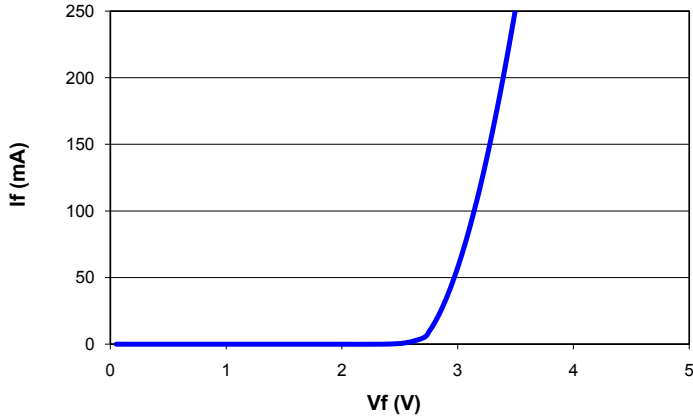

Wavelength Shift vs Forward Current

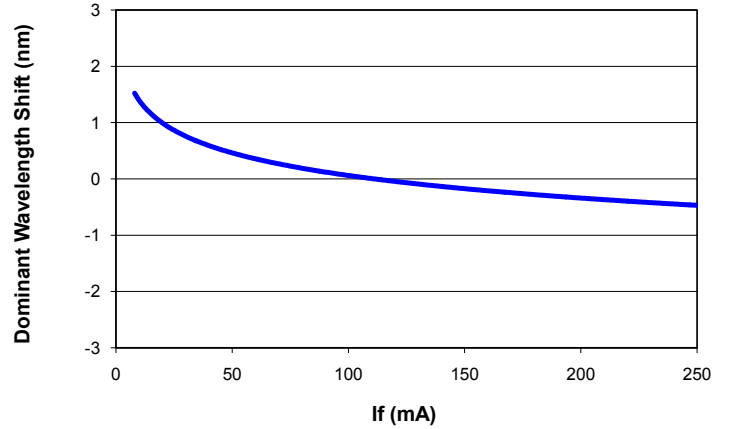

Relative Intensity vs Forward Current

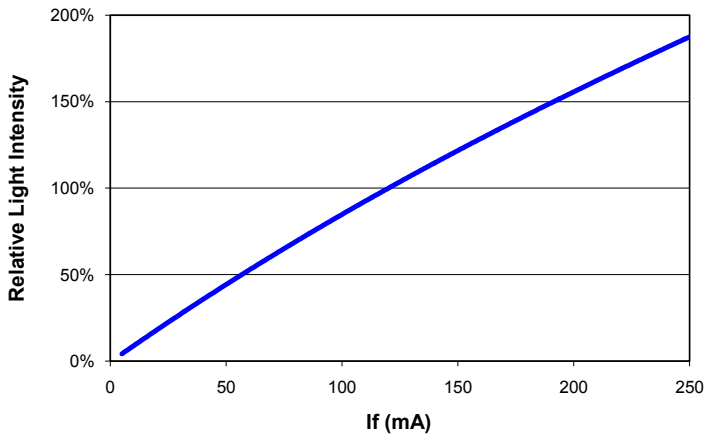

Voltage Shift vs Junction Temperature

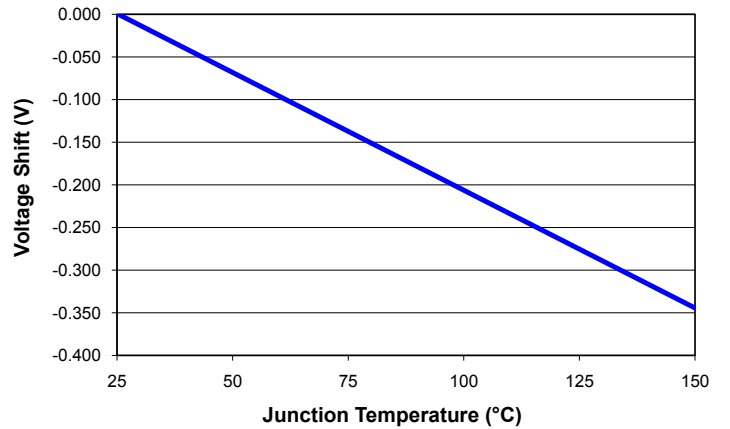

Relative Light Intensity vs Junction Temperature

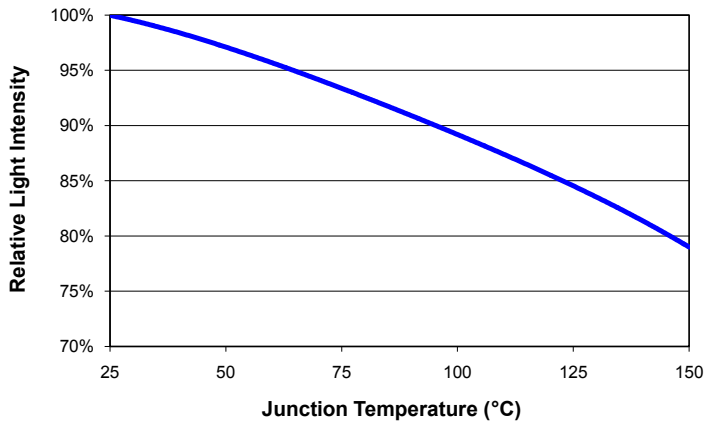

Dominant Wavelength Shift vs Junction Temperature

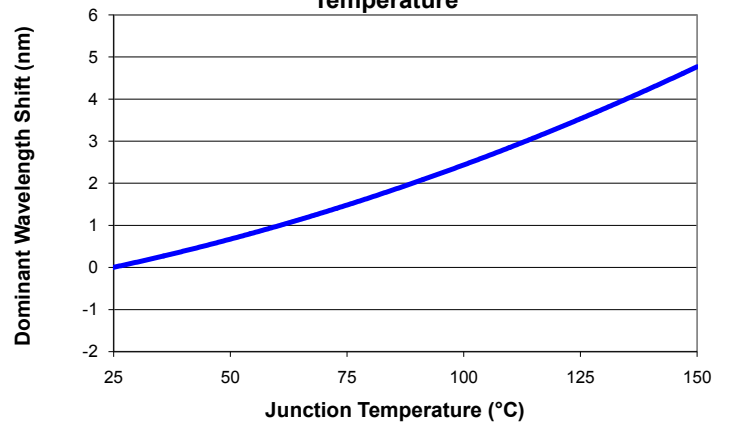

Radiation Pattern

This is a representative radiation pattern for the TR5270M LED product. Actual patterns will vary slightly for each chip.

