

DESCRIPTION: MALE - DIP SOLDER - MACHINED - ECONOMY

No. OF PINS	DIMENSIONS							
	A	B	C	D	E	F	G	H
9	1.213	0.984	0.666	0.329	0.236	0.756	0.496	0.427
	30.80	24.99	16.92	8.36	5.99	19.20	12.60	10.85
15	1.541	1.312	0.994	0.329	0.236	1.091	0.496	0.427
	39.15	33.32	25.25	8.36	5.99	27.70	12.60	10.85
25	2.087	1.852	1.534	0.329	0.236	1.618	0.496	0.427
	53.00	47.04	38.96	8.36	5.99	41.10	12.60	10.85

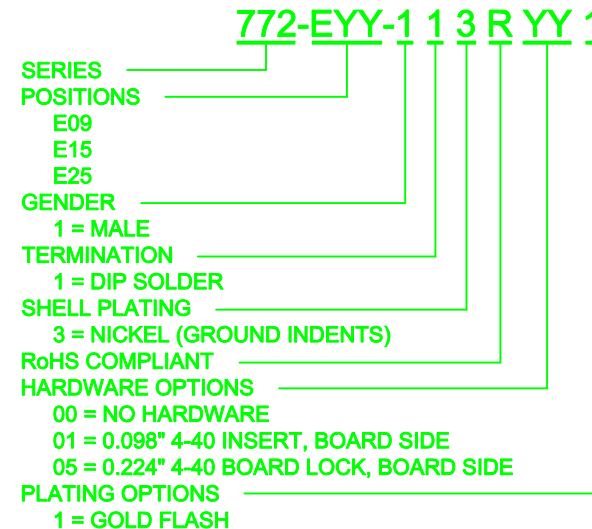
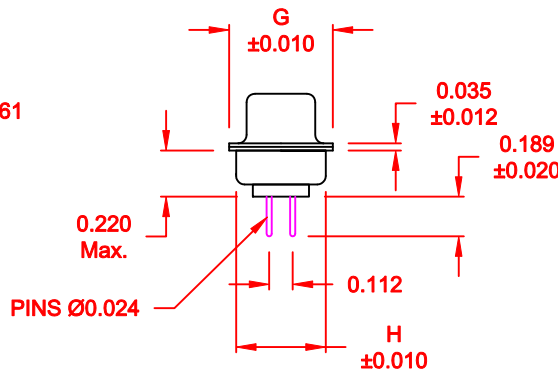
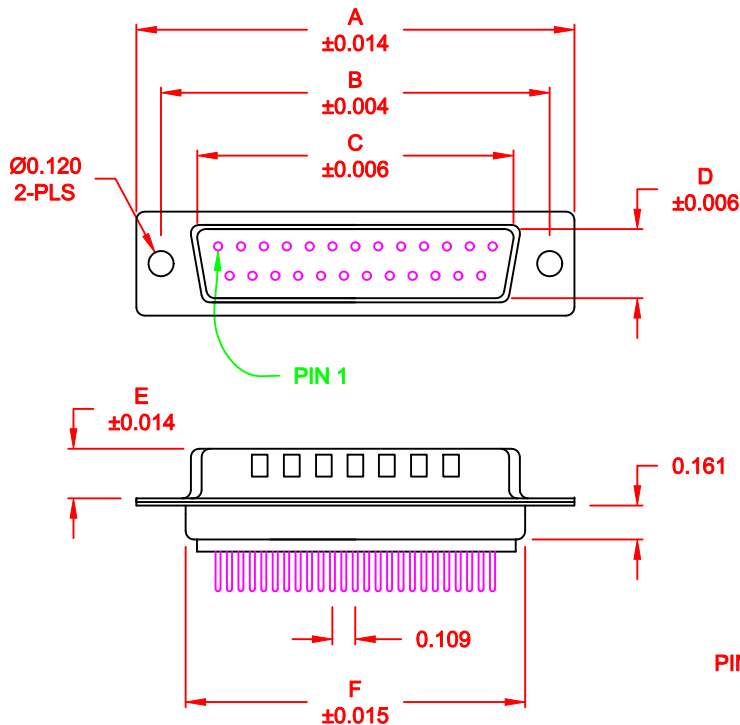

MATERIAL:

SHELL: STEEL, NICKEL PLATED
 INSULATOR: UL 94V-O RATED, WHITE PA6T
 PROCESS TEMP.: 260° C
 CONTACT: BRASS
 SEALING MATERIAL: F08 FLEXIBLE ADHESIVE

ELECTRICAL:

CURRENT RATING: 5 AMPS
 CONTACT RESISTANCE: 15 mOhms Max.
 INSULATION RESISTANCE: 1,000 MOhms min.
 VOLTAGE: 500VAC FOR 1 MINUTE
 TEMPERATURE: -50° C TO 100° C

MEETS IP67 STANDARDS
 (SEE PAGE 3 FOR SEALING DETAILS)

DO NOT SCALE FROM DRAWING

RoHS COMPLIANT

	THESE DRAWINGS AND SPECIFICATIONS ARE THE PROPERTY OF NorComp AND SHALL NOT BE REPRODUCED, COPIED OR USED AS THE BASIS FOR THE MANUFACTURE OF SALE OF APPARATUS WITHOUT WRITTEN PERMISSION.		DRAWN: PAM JENKINS	DATE: 9-18-08
			CHECKED:	DATE:
NorComp		SCALE: 1 : 1	SHEET 1 OF 3	REV 2
		DWG NO. 772-EYY-113RYY1		

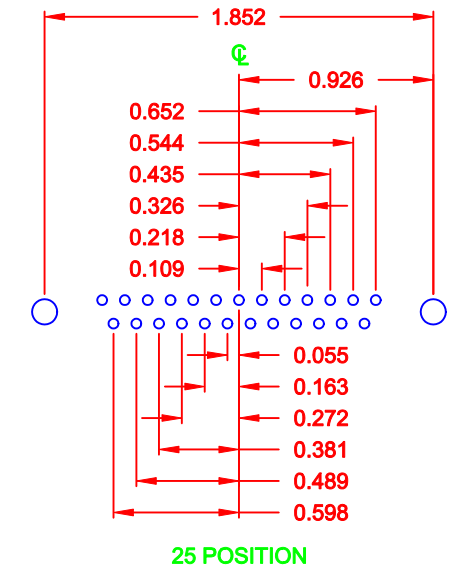
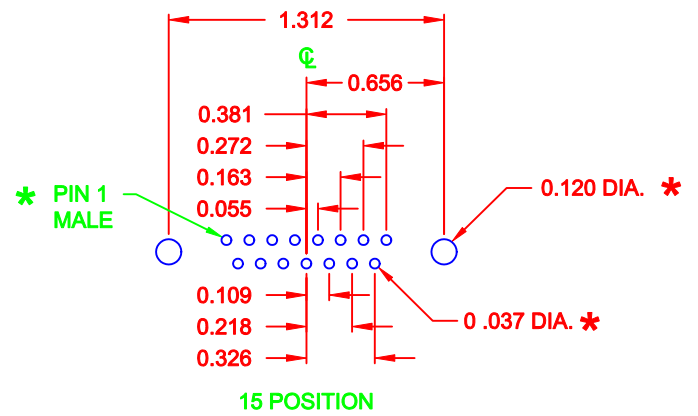
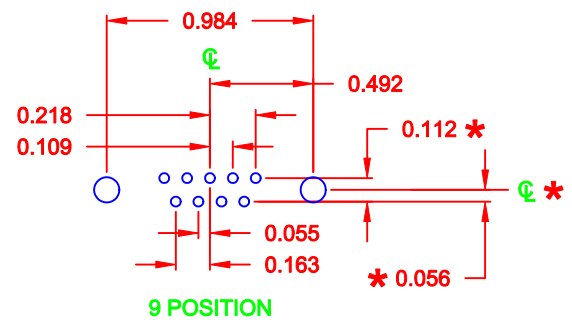

* TYP. ON ALL SIZES

DO NOT SCALE FROM DRAWING

	THESE DRAWINGS AND SPECIFICATIONS ARE THE PROPERTY OF NorComp AND SHALL NOT BE REPRODUCED, COPIED OR USED AS THE BASIS FOR THE MANUFACTURE OF SALE OF APPARATUS WITHOUT WRITTEN PERMISSION.		DRAWN: PAM JENKINS	DATE: 9-18-08
			CHECKED:	DATE:
NorComp		SCALE: FULL	SHEET 2 OF 3	REV 2
		DWG NO. 772-EYY-113RYY1		

HARDWARE OPTIONS

ALL CLINCH-NUTS ARE 4-40 INTERNAL THREADS

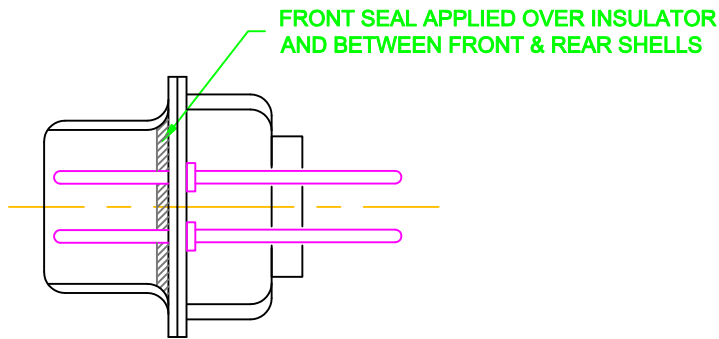
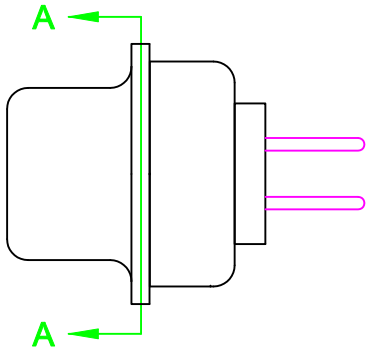

DETAIL A-A

01X 0.098" (BOARD SIDE) - CN1

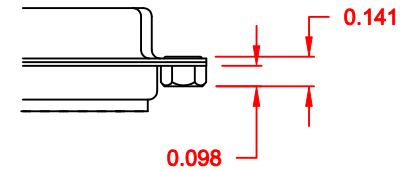

05X 0.224" BOARD SIDE - CN10

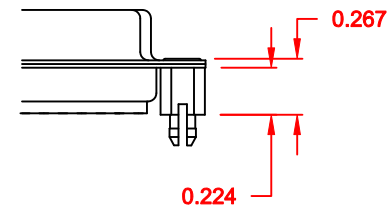

DO NOT SCALE FROM DRAWING



THESE DRAWINGS AND SPECIFICATIONS ARE THE PROPERTY OF NorComp AND SHALL NOT BE REPRODUCED, COPIED OR USED AS THE BASIS FOR THE MANUFACTURE OF SALE OF APPARATUS WITHOUT WRITTEN PERMISSION.

DRAWN:
C. SMITH

DATE:
06-10-09

CHECKED:

DATE:

NorComp

SCALE: **2.5 : 1** SHEET **3** OF **3** REV **2**

DWG NO. **772-EYY-113RYY1**