

Isolated Digital Output Board
for PCI (Internal power supply)
PO-32B(PCI)H



* Specifications, color and design of the products are subject to change without notice.

Features

A different external power supply can be used for each common pin as it is shared by 16 channels.

The PCI bus (personal computer) and the output interface are isolated from each other by an Optocoupler, offering good noise immunity.

Up to 35VDC, 100mA per signal, max. output.

Zener diode connected to output transistors for protection from surge voltage. Overcurrent protective device provided for every eight channels of output transistors.

The board carries an Optocoupler driving power supply. You can select whether to use the internal power supply or an external power supply.

This board is a PCI-compliant interface board for output of digital signals.

The PC can be used to input the on/off state of a switch and to control a relay.

This product can output up to 32 channels.

Using the bundled driver library package [API-PAC(W32)], you can create Windows application software for this board in your favorite programming language supporting Win32 API functions, such as Visual Basic or Visual C/C++.

- * The contents in this document are subject to change without notice.
- * Visit the CONTEC website to check the latest details in the document.
- * The information in the data sheets is as of April, 2018.

Specification

Item	Specification
Output section	
Output format	Optocoupler isolated input (Compatible with current sink output)(Negative logic *1)
Number of output signal channels	32 channels(One common power supply per 16 channels)
Output rating	Output voltage 35VDC (Max.) Output current 100mA (par channel) (Max.)
Residual voltage with output on	0.5V or less (Output current≤50mA), 1.0V or less (Output current≤100mA)
Surge protector	Zener diode RD47FM(NEC) or equivalent
Response time	200μsec within
Common section	
I/O address	Any 32-byte boundary
Interruption level	Not used
Max. board count for connection	16 boards including the master board
External circuit power supply	12 - 24VDC(±10%)
Internal power	12VDC 240mA *2
Power consumption	5VDC 1200mA (Max.) (Using the internal power) 5VDC 300mA (Max.) (Using the External power)
Operating condition	0 - 50°C, 10 - 90%RH (No condensation)
Allowable distance of signal extension	Approx. 50m (depending on wiring environment)
PCI bus specification	32bit, 33MHz, Universal key shapes supported *3
Dimension (mm)	176.41(L) x 105.68(H)
Weight	150g
Standard	VCCI Class A, CE Marking (EMC Directive Class A, RoHS Directive)

- *1 Data "0" and "1" correspond to the High and Low levels, respectively.
- *2 When the internal power supply is used, the switch section of output channel consumes a maximum of 40 mA and thus the output current to be supplied from the board is 200 mA.
- *3 This board requires +5V power supply from expansion slots (it does not operate in the environment of only +3.3V power supply).

Board Dimensions

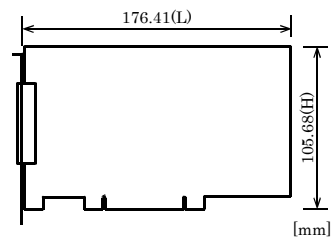

The standard outside dimension (L) is the distance from the end of the board to the outer surface of the slot cover.

Support Software

Windows version of digital I/O driver API-DIO(WDM)/API-DIO(98/PC)

[Stored on the bundled disk driver library API-PAC(W32)]

The API-DIO(WDM) is the Windows version driver library software that provides products in the form of Win32 API functions (DLL). Various sample programs such as Visual Basic and Visual C++, etc and diagnostic program *1 useful for checking operation is provided.

For more details on the supported OS, applicable language and new information, please visit the CONTEC's Web site.

Linux version of digital I/O driver API-DIO(LNX)

[Stored on the bundled disk driver library API-PAC(W32)]

The API-DIO(LNX) is the Linux version driver software which provides device drivers (modules) by shared library and kernel version. Various sample programs of gcc are provided.

For more details on the supported OS, applicable language and new information, please visit the CONTEC's Web site.

LabVIEW-support data acquisition library DAQfast for LabVIEW

(Available for downloading (free of charge) from the CONTEC web site.)

This is a data collection library to use in the LabVIEW by National Instruments. With Polymorphic VI, our design enables a LabVIEW user to operate seamlessly. Our aim is that the customers to perform easily, promptly what they wish to do.

For more details on the library and download of DAQfast for LabVIEW, please visit the CONTEC's Web site.

Data acquisition library for LabVIEW VI-DAQ (Available for downloading (free of charge) from the CONTEC web site.)

This is a VI library to use in National Instruments LabVIEW. VI-DAQ is created with a function form similar to that of LabVIEW's Data Acquisition VI, allowing you to use various devices without complicated settings.

For more details on the library and download of VI-DAQ, please visit the CONTEC's Web site.

Cable & Connector (Option)

- Flat Cable with a 37-Pin D-type Connectors on 2Ends
 - : PCB37P-1.5 (1.5m)
 - : PCB37P-3 (3m)
 - : PCB37P-5 (5m)

- Shielded cable with two 37-pin D- Type connectors
 - : PCB37PS-0.5P (0.5m)
 - : PCB37PS-1.5P (1.5m)
 - : PCB37PS-3P (3m)
 - : PCB37PS-5P (5m)

- Flat Cable with a 37-pin D-type Connector
 - : PCA37P-1.5 (1.5m)
 - : PCA37P-3 (3m)
 - : PCA37P-5 (5m)

- Shielded Cable with Two 37-pin D-Type Connectors
 - : PCA37PS-0.5P (0.5m)
 - : PCA37PS-1.5P (1.5m)
 - : PCA37PS-3P (3m)
 - : PCA37PS-5P (5m)

Accessories (Option)

- Screw Terminal (M3 x 37P) : EPD-37A *1*2
- Screw Terminal (M3.5 x 37P) : EPD-37 *1
- General Purpose Terminal : DTP-3A *1
- Termination Panel : DTP-4C *1
- Signal Monitor for Digital I/O : CM-32L *1

*1 A PCB37P or PCB37PS optional cable is required separately.
 *2 "Spring-up" type terminal is used to prevent terminal screws from falling off.

* Check the CONTEC's Web site for more information on these options.

Packing List

- Board [PO-32B(PCI)H] ...1
- First step guide ... 1
- Disk *1 [API-PAC(W32)] ...1
- Warranty Certificate...1
- Serial Number Label...1

*1 The bundled disk contains the driver software and User's Guide.

Block Diagram

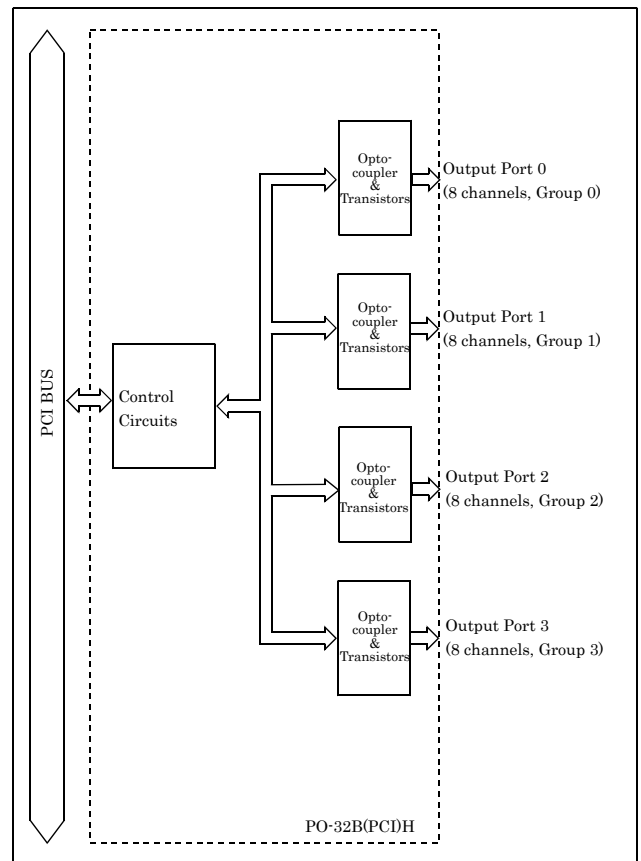

Using the On-board Connectors

Connecting a Device to a Connector

To connect an external device to this board, plug the cable from the device into the interface connector shown below.

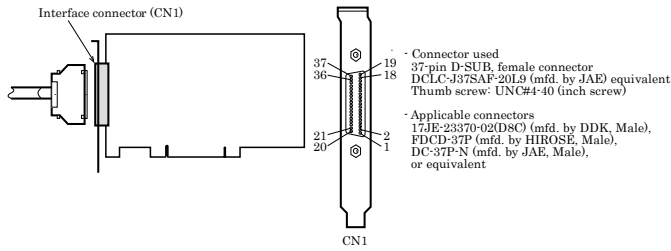

Connector Pin Assignment

Pin Assignments of Interface Connector

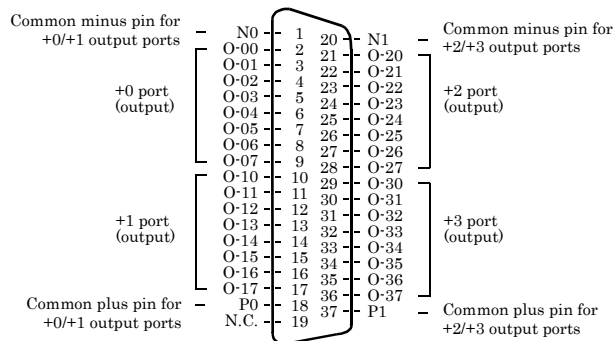

O-00 - O-37	32 output signal pins. Connect output signals from the external device to these pins.
P0, P1	When the external power supply is selected, its positive side is connected to this pin. When the internal power supply is used, this pin outputs power at +12 V. These pins are common to 16 input signal pins.
N0, N1	When the external power supply is selected, its negative side is connected to this pin. When the internal power supply is selected, this pin serves as the ground. These pins are common to 16 input signal pins.
N.C.	This pin is left unconnected.

Connecting Output Signals

Connect the output signals to a current-driven controlled device such as a relay or LED. The board controls turning on/off the current-driven controlled device using a digital value.

Output Circuit

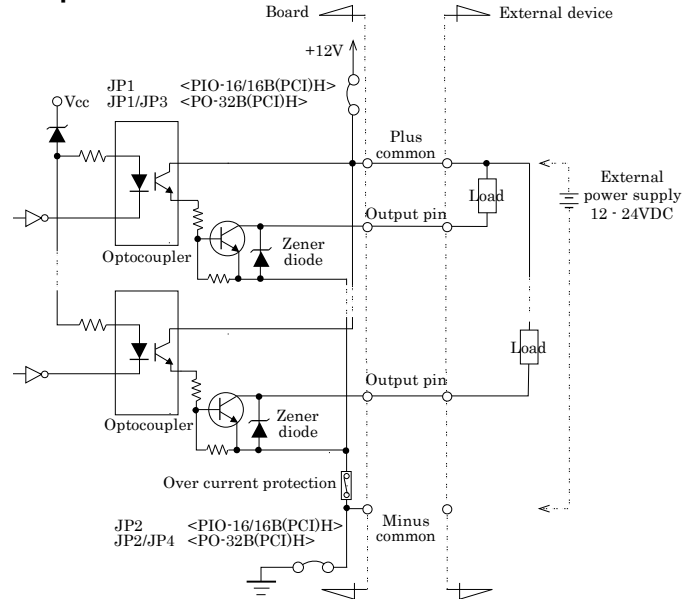

The output circuits of interface blocks of the PIO-16/16B(PCI)H and this product are illustrated in the image above. The signal output section as an Optocoupler isolated open-collector output (current sink type). To drive the output section, the on-board internal power supply must be used or an external power supply is required. The rated output current per channel is 100 mA at maximum. The output section can also be connected to a TTL level input as it uses a low-saturated transistor for output. The residual voltage (low-level voltage) between the collector and emitter with the output on is 0.5 V or less at an output current within 50 mA or at most 1.0 V at an output current within 100 mA. To protect against surge voltage, a Zener diode is connected to the output transistor. Also, an overcurrent protection circuit is attached to a unit of eight output channels.

CAUTION

When the PC is turned on, all output are reset to OFF. See the "Selecting the internal or external power supply" section to connect the jumpers depending on the power supply to be used.

Connection to the LED

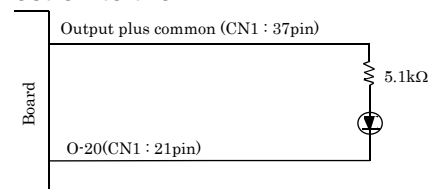

When "1" is output to a relevant bit, the corresponding LED comes on. When "0" is output to the bit, in contrast, the LED goes out.

Example of Connection to TTL Level Input

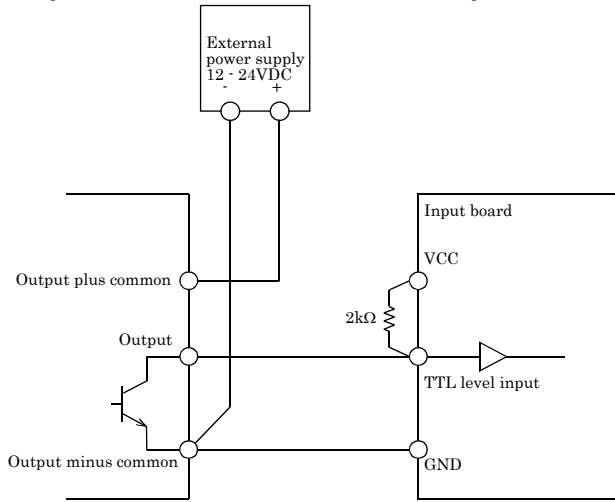

Connecting the Sink Type Output and Sink Output Support Input

The following example shows a connection between a sink type output (output board) and a sink output support input (input board). Refer to this connection example when you connect such boards to each other.

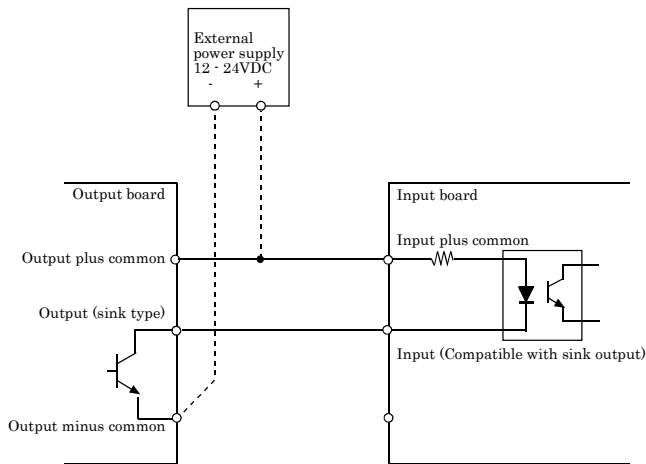

Differences between the PO-32B(PCI)H And PO-32B(PCI)

This product is connector-pin compatible with the conventional PO-32B(PCI) but has the following differences from it:

- (1) Protective elements provided for outputs
 - PO-32B(PCI)H : Surge protector: Zener diode
 - PO-32B(PCI) : Nothing
- (2) Different in board dimensions
 - PO-32B(PCI)H : 176.41(L) x 105.68(H) mm
 - PO-32B(PCI) : 176.41(L) x 106.68(H) mm