

1.0 General Description

The AMIS-30623 is a single-chip microstepping motordriver with position controller and control/diagnostic interface. It is ready to build dedicated mechatronics solutions connected remotely with a LIN master.

The chip receives positioning instructions through the bus and subsequently drives the motor coils to the desired position. The on-chip position controller is configurable (OTP or RAM) for different motor types, positioning ranges and parameters for speed, acceleration and deceleration. The advanced motion qualification mode enables verification of the complete mechanical system in function of the selected motion parameters. The AMIS-30623 acts as a slave on the LIN bus and the master can fetch specific status information like actual position, error flags, etc. from each individual slave node.

An integrated sensorless step-loss detection prevents the positioner from losing steps and stops the motor when running into stall. This enables silent, yet accurate position calibrations during a referencing run and allows semi-closed loop operation when approaching the mechanical end-stops.

The chip is implemented in I2T100 technology, enabling both high voltage analog circuitry and digital functionality on the same chip. The AMIS-30623 is fully compatible with the automotive voltage requirements.

2.0 Product Features

Motordriver

- Microstepping technology
- Sensorless step-loss detection
- Peak current up to 800mA
- Fixed frequency PWM current-control
- Automatic selection of fast and slow decay mode
- No external fly-back diodes required
- 14V/24V compliant
- Motion Qualification Mode

Controller with RAM and OTP memory

- Position controller
- Configurable speeds, and acceleration
- Input to connect optional motion switch

LIN interface

- Both physical and data-link layers (conform to LIN rev. 1.3)
- Field-programmable node addresses
- Dynamically allocated identifiers
- Full diagnostics and status information

Protection

- Over-current protection
- Under-voltage management
- Open circuit detection
- High-temp warning and management
- Low-temp flag
- LIN bus short-circuit protection to supply and ground
- Lost LIN safe operation

Power Saving

- Power-down supply current < 100µA
- 5V regulator with wake-up on LIN activity

EMI compatibility

- LIN bus integrated slope control
- HV outputs with slope control

3.0 Applications

The AMIS-30623 is ideally suited for small positioning applications. Target markets include: automotive (headlamp alignment, HVAC, idle control, cruise control), industrial equipment (lighting, fluid control, labeling, process control, XYZ tables, robots) and building automation (HVAC, surveillance, satellite dish, renewable energy systems). Suitable applications typically have multiple axes or require mechatronic solutions with the driver chip mounted directly on the motor.

4.0 Ordering Information

Table 1: Ordering information

Part No.	Package	Peak Current	Temp. Range	Stop voltage low threshold	Ordering Code Tubes	Ordering Code Tapes
AMIS-30623A AGA	SOIC-20	800 mA	-40°C.....125°C	Typ. 8.5V	N/A	N/A
AMIS-30623B AGA	SOIC-20	800 mA	-40°C.....125°C	Typ. 7.5V	N/A	N/A
AMIS-30623A ANA	NQFP-32 (7 x 7 mm)	800 mA	-40°C.....125°C	Typ. 8.5V	N/A	N/A
AMIS-30623B ANA	NQFP-32 (7 x 7 mm)	800 mA	-40°C.....125°C	Typ. 7.5V	N/A	N/A

5.0 Quick Reference Data

Table 2: Absolute Maximum Ratings

Parameter		Min.	Max.	Unit
Vbb	Supply voltage	-0.3	+40 ⁽¹⁾	V
Vlin	Bus input voltage	-80	+80	V
Tamb	Ambient temperature under bias ⁽²⁾	-50	+150	°C
Tst	Storage temperature	-55	+160	°C
Vesd ⁽³⁾	Electrostatic discharge voltage on LIN pin	-4	+4	kV
	Electrostatic discharge voltage on other pins	-2	+2	kV

Notes :

- (1) For limited time <0.5s
- (2) The circuit functionality is not guaranteed.
- (3) Human body model (100 pF via 1.5 kΩ, according to MIL std. 883E, method 3015.7)

Table 3: Operating Ranges

Parameter		Min	Max	Unit
Vbb	Supply voltage	+8	+29	V
Top	Operating temperature range	Vbb ≤ 18V	+125	°C
		Vbb ≤ 29V	+85	°C

6.0 Contents

1.0 General Description.....	1
2.0 Product Features.....	1
3.0 Applications.....	2
4.0 Ordering Information.....	2
5.0 Quick Reference Data.....	2
6.0 Content.....	3
7.0 Block Diagram.....	5
8.0 Pin Out.....	6
9.0 Package Thermal Resistance.....	7
9.1 SOIC-20.....	7
9.2 NQFP-32.....	7
10.0 DC Parameters.....	8
11.0 AC Parameters.....	10
12.0 Typical Application.....	12
13.0 Positioning parameters.....	12
13.1 Stepping Modes.....	12
13.2 Maximum Velocity.....	13
13.3 Minimum Velocity.....	13
13.4 Acceleration and Deceleration.....	14
13.5 Positioning.....	14
13.5.1. Position Ranges.....	15
13.5.2. Secure Position.....	15
13.5.3. Shaft.....	15
14.0 Structural Description.....	16
14.1 Stepper Motordriver.....	16
14.2 Control Logic (Position Controller and Main control).....	16
14.3 Motion Detection.....	16
14.4 LIN Interface.....	16
14.5 Miscellaneous.....	16
15.0 Functions Description.....	17
15.1 Position Controller.....	17
15.1.1. Positioning and Motion Control.....	17
15.1.2. Dual positioning.....	19
15.1.3. Position Periodicity.....	19
15.1.4. Hardwired Address HW2.....	20
15.1.5. External Switch SWI.....	22
15.2 Main Control and Register, OTP memory + ROM.....	23
15.2.1. Power-up Phase.....	23
15.2.2. Reset State.....	23
15.2.3. Soft Stop.....	23
15.2.4. Sleep Mode.....	24
15.2.5. Thermal Shutdown Mode.....	24
15.2.6. Temperature Management.....	24
15.2.7. Autarkic functionality in under-voltage condition.....	25
15.2.8. OTP register.....	26
15.2.9. RAM Registers.....	31
15.2.10. Flags Table.....	32
15.3 Motordriver.....	35
15.3.1. Current waveforms in the coils.....	35
15.3.2. PWM Regulation.....	36
15.3.3. PWM jitter.....	36
15.3.4. Motor Starting Phase.....	36
15.3.5. Motor Stopping Phase.....	36
15.3.6. Charge Pump Monitoring.....	37
15.3.7. Electrical Defect on Coils, Detection and Confirmation.....	37

15.3.8. Motor Shutdown Mode	38
15.4 Motion detection.....	39
16.0 Lin Controller	42
16.1 General Description	42
16.2 Slave Operational Range for Proper Self Synchronization	42
16.3 Functional Description	43
16.3.1. Analog Part.....	43
16.3.2. Protocol Handler.....	43
16.3.3. Electro Magnetic Compatibility	43
16.4 Error Status Register	43
16.5 Physical Address of the Circuit	43
16.6 LIN Frames	44
16.6.1. Writing frames	44
16.6.2. Reading frames	45
16.6.3. Preparing frames.....	45
16.6.4. Dynamic assignment of Identifiers.....	46
16.7 Commands table.....	47
16.8 LIN lost behavior	47
16.8.1. Introduction.....	47
16.8.2. Sleep enable	47
16.8.3. Fail Safe Motion	48
16.8.4. Autonomous motion	48
17.0 LIN Application Commands	51
17.1 Introduction	51
17.2 Application Commands	52
18.0 Resistance to Electrical and Electromagnetic Disturbances	63
18.1 Electrostatic Discharges	63
18.2 Electrical transient conduction along supply lines	63
18.3 EMC.....	63
18.4 Power Supply Micro-interruptions	63
19.0 Package Outline.....	64
19.1 SOIC-20: Plastic small outline; 20 leads; body width 300mil. AMIS reference: SOIC300 20 300G	64
19.2 NQFP-32: No lead Quad Flat Pack; 32 pins; body size 7 x 7 mm. AMIS reference: NQFP-32.....	65
20.0 Soldering	66
20.1 Introduction to Soldering Surface Mount Packages	66
20.2 Re-flow Soldering.....	66
20.3 Wave Soldering.....	66
20.4 Manual Soldering.....	66
21.0 Company or Product Inquiries	67
22.0 Document History	67

7.0 Block Diagram

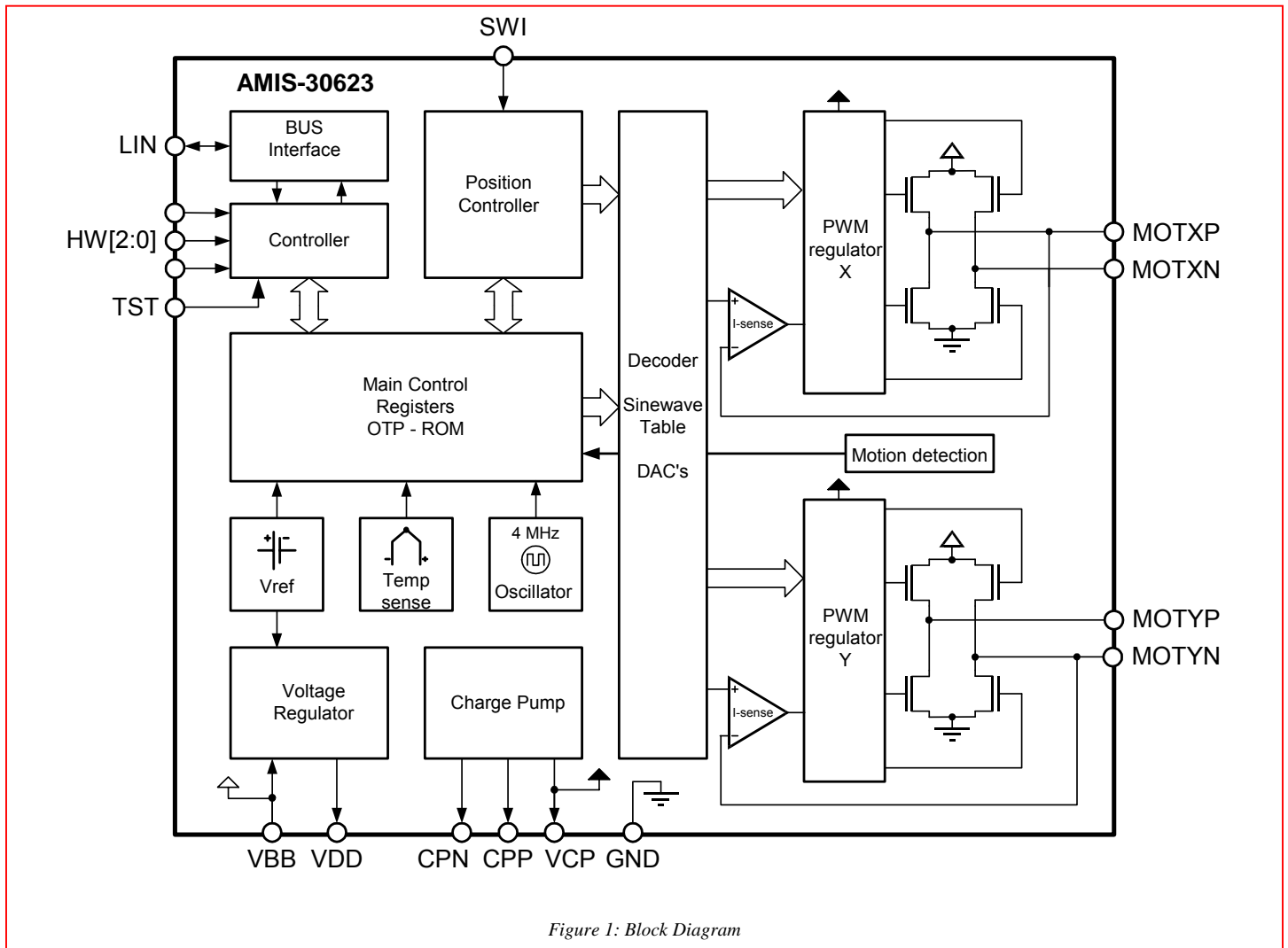

Figure 1: Block Diagram

8.0 Pin Out

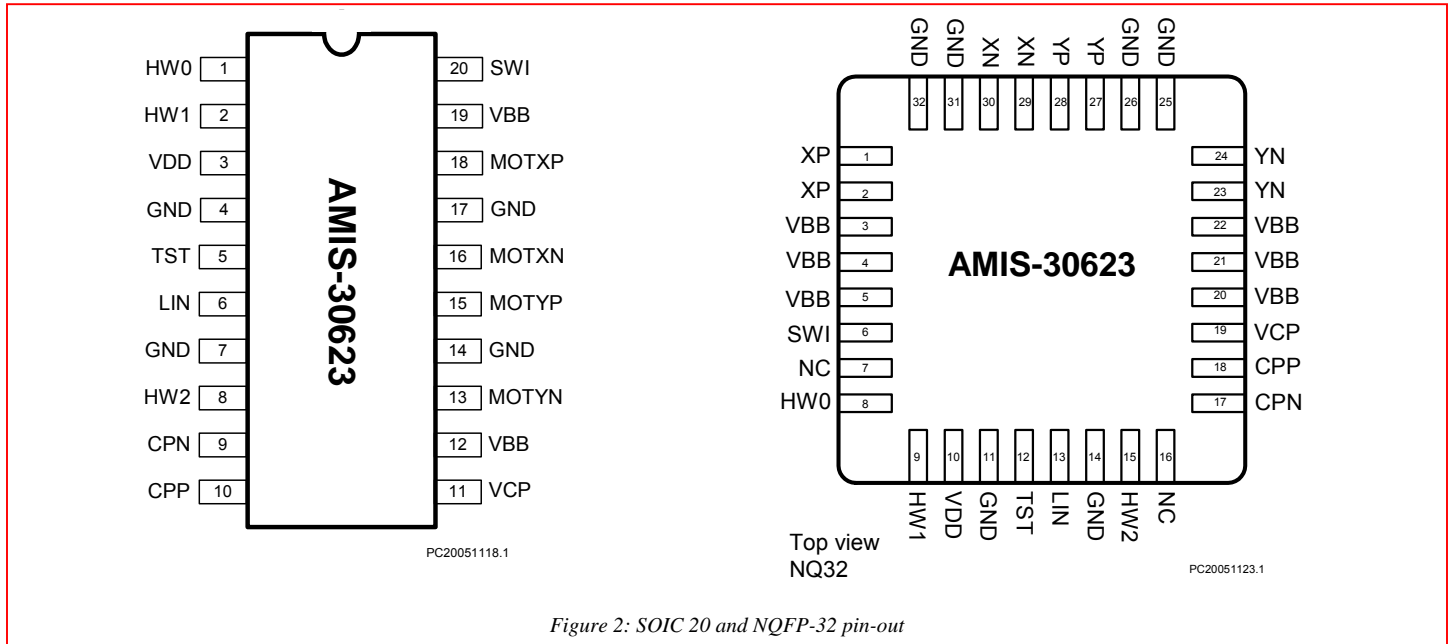

Table 4: Pin Description

Pin Name	Pin Description	SOIC-20	NQFP-32
HW0	Bit 0 of LIN-ADD	1	8
HW1	Bit 1 of LIN-ADD	2	9
VDD	Internal supply (needs external decoupling capacitor)	3	10
GND	Ground, heat sink	4,7,14,17	11, 14, 25, 26, 31, 32
TST	Test pin (to be tied to ground in normal operation)	5	12
LIN	LIN-bus connection	6	13
HW2	Bit 2 LIN-ADD	8	15
CPN	Negative connection of pump capacitor (charge pump)	9	17
CPP	Positive connection of pump-capacitor (charge pump)	10	18
VCP	Charge-pump filter-capacitor	11	19
VBB	Battery voltage supply	12,19	3, 4, 5, 20, 21, 22
MOTYN	Negative end of phase Y coil	13	23, 24
MOTYP	Positive end of phase Y coil	15	27, 28
MOTXN	Negative end of phase X coil	16	29, 30
MOTXP	Positive end of phase X coil	18	1, 2
SWI	Switch input	20	6
NC	Not connected (to be tied to ground)		7, 16

9.0 Package Thermal Resistance

9.1 SOIC-20

To lower the junction-to-ambient thermal resistance, it is recommended to connect the ground leads to a PCB ground plane layout as illustrated in Figure 3. The junction-to-case thermal resistance is depending on the copper area, copper thickness, PCB thickness and number of copper layers. Calculating with a total area of 460 mm², 35µm copper thickness, 1.6mm PCB thickness and 1layer, the thermal resistance is 28°C/W, leading to a junction-ambient thermal resistance of 63°C/W,

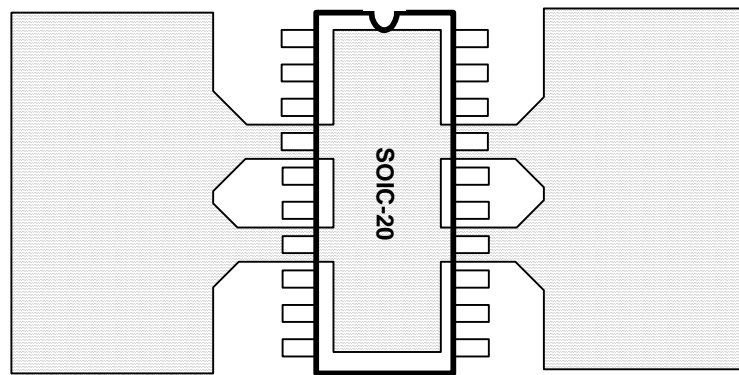

PC20041128.1

Figure 3: PCB Ground Plane Layout Condition

9.2 NQFP-32

The NQFP is designed to provide superior thermal performance. Using an exposed die pad on the bottom surface of the package, is partly contributing to this. In order to take full advantage of this, the PCB must have features to conduct heat away from the package. A thermal grounded pad with thermal vias can achieve this. With a layout as shown in Figure 4 the thermal resistance junction – to – ambient can be brought down to a level of 25°C/W.

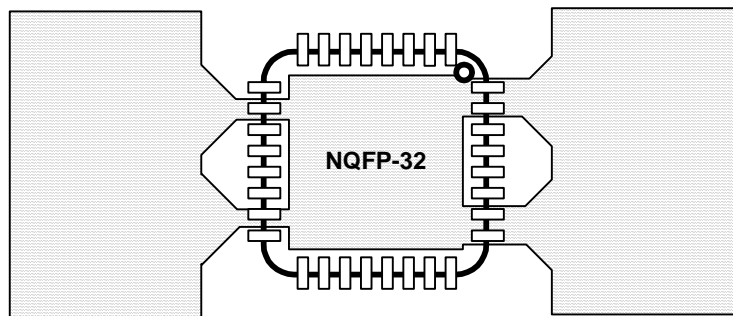

PC20041128.2

Figure 4: PCB Ground Plane Layout Condition

10.0 DC Parameters

The DC parameters are given for V_{bb} and temperature in their operating ranges. Convention: currents flowing in the circuit are defined as positive.

Table 5: DC Parameters

Symbol	Pin(s)	Parameter	Test Conditions	Min.	Typ.	Max.	Unit
Motordriver							
$I_{MSmax,Peak}$	MOTXP MOTXN MOTYP MOTYN	Max current through motor coil in normal operation			800		mA
$I_{MSmax,RMS}$		Max RMS current through coil in normal operation			570		mA
I_{MSabs}		Absolute error on coil current		-10		10	%
I_{MSrel}		Error on current ratio I_{coilx} / I_{coily}		-7		7	%
R_{DSon}		On resistance for each motor pin (including bond wire) at I_{MSmax}	$V_{bb} = 12V, T_j = 50\text{ }^\circ\text{C}$ $V_{bb} = 8V, T_j = 50\text{ }^\circ\text{C}$ $V_{bb} = 12V, T_j = 150\text{ }^\circ\text{C}$ $V_{bb} = 8V, T_j = 150\text{ }^\circ\text{C}$			0.50 0.55 0.70 0.85	1 1 1 1
I_{MSL}	Pull down current	HiZ mode			2		mA
LIN Transmitter							
I_{bus_on}	LIN	Dominant state, driver on	$V_{bus} = 1.4V$	40			mA
I_{bus_off}		Dominant state, driver off	$V_{bus} = 0V$	-1			mA
I_{bus_off}		Recessive state, driver off	$V_{bus} = V_{bat}$			20	μA
I_{bus_lim}		Current limitation		50		200	mA
R_{slave}		Pull-up resistance		20	30	47	k Ω
LIN Receiver							
V_{bus_dom}	LIN	Receiver dominant state		0		$0.4 * V_{bb}$	V
V_{bus_rec}		Receiver recessive state		$0.6 * V_{bb}$		V_{bb}	V
V_{bus_hys}		Receiver hysteresis		$0.05 * V_{bb}$		$0.2 * V_{bb}$	V
Thermal Warning & Shutdown							
T_{tw}		Thermal warning		138	145	152	$^\circ\text{C}$
$T_{tsd}(1) (2)$		Thermal shutdown			$T_{tw} + 10$		$^\circ\text{C}$
$T_{low} (2)$		Low temperature warning			$T_{tw} - 155$		$^\circ\text{C}$
Supply and Voltage Regulator							
V_{bb}	VBB	Nominal operating supply range		6.5		18	V
V_{bbOTP}		Supply voltage for OTP zapping (3)		9.0		10.0	V
I_{bat}		Total current consumption	Unloaded outputs		3.50	10.0	mA
I_{bat_s}		Sleep mode current consumption			50	100	μA
V_{dd}	VDD	Internal regulated output (4)	$8V < V_{bb} < 18V$	4.75	5	5.50	V
I_{ddStop}		Digital current consumption	$V_{bb} < UV_2$		2		mA
$V_{ddReset}$		Digital supply reset level @ power down (5)				4.5	V
I_{ddLim}		Current limitation	Pin shorted to ground			42	mA
Switch Input and Hardware Address Input							
R_{t_OFF}	SW1 HW2	Switch OFF resistance (6)	Switch to Gnd or V_{bat} .	10			k Ω
R_{t_ON}		Switch ON resistance (6)				2	k Ω
V_{bb_sw}		V_{bb} range for guaranteed operation of SW1 and HW2		6		29	V
V_{max_sw}		Maximum voltage	$T < 1s$			40V	V

Symbol	Pin(s)	Parameter	Test Conditions	Min.	Typ.	Max.	Unit
Switch Input and Hardwire Address Input							
I_{lim_sw}	SW1 HW2	Current limitation	Short to Gnd or V_{bat}		30		mA
Hardwired Address Inputs and Test Pin							
V_{low}	HW0	Input level high		$0.7 * V_{dd}$.	V
V_{high}	HW1	Input level low				$0.3 * V_{dd}$	V
HW_{hyst}	TST	Hysteresis		$0.075 * V_{dd}$			V
Charge Pump							
V_{cp}	VCP	Output voltage	$V_{bb} > 15V$	$V_{bb}+10$	$V_{bb}+12.5$	$V_{bb}+15$	V
			$8V < V_{bb} < 15V$	$2 * V_{bb} - 5$	$2 * V_{bb} - 2.5$	$2 * V_{bb}$	V
C_{buffer}		External buffer capacitor		220		470	nF
C_{pump}	CPP CPN	External pump capacitor		220		470	nF
Motion Qualification Mode Output							
V_{OUT}	SWI	Output voltage swing	TestBemf LIN command		0 - 4,85		V
R_{OUT}		Output impedance	Service mode LIN command		2		k Ω
AV		Gain = V_{SWI} / V_{BEMF}	Service mode LIN command		0,50		

Notes

- (1) No more than 100 cumulated hours in life time above T_{isd} .
- (2) Thermal shutdown and low temperature warning are derived from thermal warning.
- (3) A 10 μ F buffer capacitor of between VBB and GND is minimum needed. Short connections to the power supply are recommended.
- (4) Pin VDD must not be used for any external supply
- (5) The RAM content will not be altered above this voltage.
- (6) External resistance value seen from pin SWI or HW2, including 1 k Ω series resistor.

Table 6: UV Limits for Different Version

Symbol	Pin(s)	Parameter	Test Conditions	Min.	Typ.	Max.	Unit
Supply Thresholds AMIS-30623A							
UV_1	VBB	Stop voltage high threshold		8.8	9.4	9.9	V
UV_2		Stop voltage low threshold		8.1	8.5	9.0	V
Supply Thresholds AMIS-30623B							
UV_1	VBB	Stop voltage high threshold		7.8	8.4	8.9	V
UV_2		Stop voltage low threshold		7.1	7.5	8.0	V

11.0 AC Parameters

The AC parameters are given for V_{bb} and temperature in their operating ranges.

The LIN transmitter/receiver parameters conform to LIN Protocol Specification Revision 1.3. Unless otherwise specified $8V < V_{bb} < 18V$, Load for propagation delay = $1k\Omega$, Load for slope definitions : [L1] = $1nF / 1k\Omega$; [L2] = $6.8nF / 660\Omega$; [L3] = $10nF / 510\Omega$.

Table 7: AC Parameters

Symbol	Pin(s)	Parameter	Test Conditions	Min.	Typ.	Max.	Unit
Power-up							
T_{pu}		Power-up time	Guaranteed by design			10	ms
Internal Oscillator							
f_{osc}		Frequency of internal oscillator		3.6	4.0	4.4	MHz
LIN Transmitter							
$T_{slope_F/R}$	LIN	Slope time falling or rising edge	Extrapolated between 40% and 60% V_{bus_dom}	3.5		22.5	μs
T_{slope_Sym}		Slope time symmetry (1)	$T_{slope_F} - T_{slope_R}$	-4		4	μs
T_{tr_F}		Propagation delay TxD low to bus		0.1	1	4	μs
T_{tr_R}		Propagation delay TxD high to bus		0.1	1	4	μs
T_{sym_tr}		Transmitter delay symmetry	$T_{tr_F} - T_{tr_R}$	-2		2	μs
LIN Receiver							
T_{rec_F}	LIN	Propagation delay bus dominant to RxD low		0.1	4	6	μs
T_{rec_R}		Propagation delay bus recessive to RxD high		0.1	4	6	μs
T_{sym_rec}		Receiver delay symmetry	$T_{rec_F} - T_{rec_R}$	-2		2	μs
T_{wake}		Wake-up delay time		50	100	200	μs
Switch Input and Hardwire Address Input							
T_{sw}	SW1	Scan pulse period (2)			1024		μs
T_{sw_on}	HW2	Scan pulse duration			128		μs
Motordriver							
F_{pwm}	MOTxx	PWM frequency (2)	PWMfreq = 0 (3)	20.6	22.8	25.0	kHz
			PWMfreq = 1 (3)	41,2	45,6	50,0	kHz
F_{jit_depth}		PWM jitter modulation depth	PWMJen = 1 (3)		10		%
T_{brise}		Turn-on transient time	Between 10% and 90%		170		ns
T_{bfall}		Turn-off transient time			140		ns
T_{stab}		Run current stabilization time		29	32	35	ms
Charge Pump							
f_{CP}	CPN CPP	Charge pump frequency (2)			250		kHz

Notes

- (1) For loads [L1] and [L2]
- (2) Derived from the internal oscillator
- (3) See [SetMotorParam](#) and [PWM regulator](#)

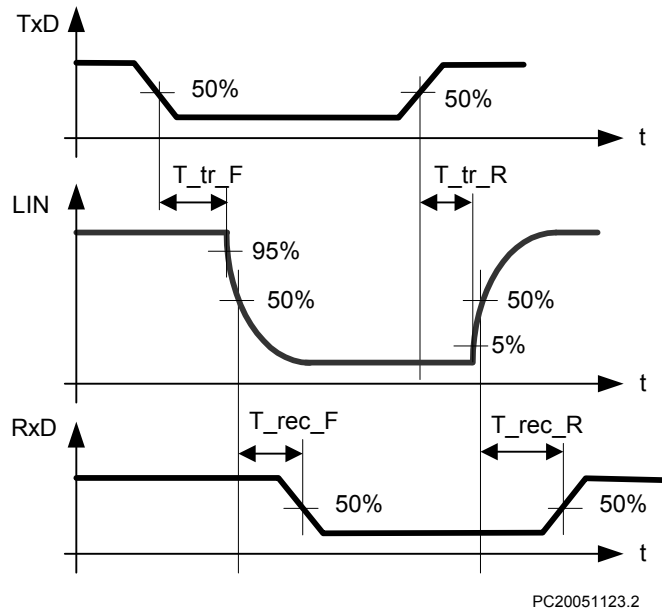

Figure 5: LIN Delay Measurement

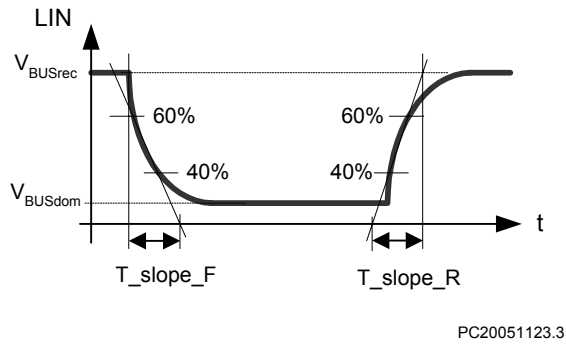

Figure 6: LIN Slope Measurement

12.0 Typical Application

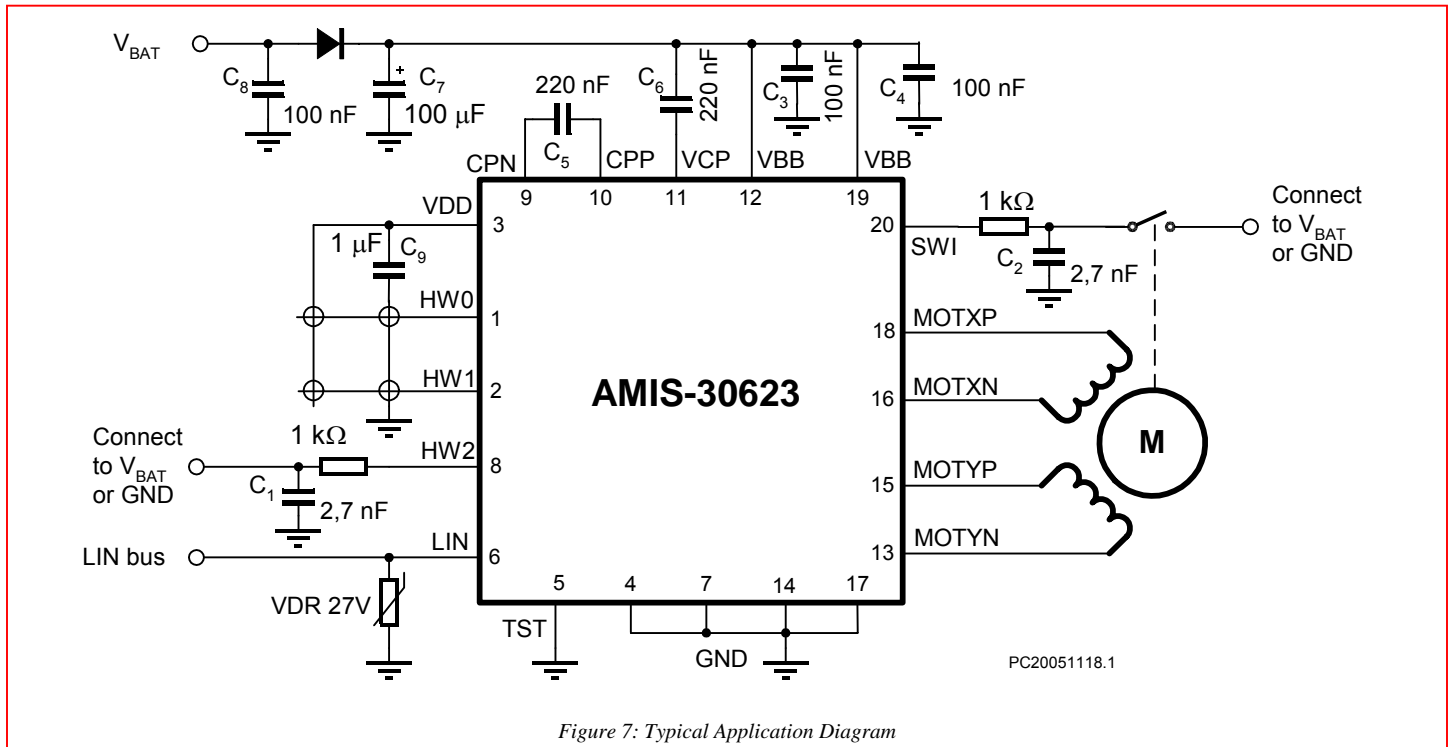

Figure 7: Typical Application Diagram

Notes:

- (1) All resistors are $\pm 5\%$, $\frac{1}{4}$ W
- (2) C_1 , C_2 minimum value is 2.7nF, maximum value is 10nF
- (3) Depending on the application, the ESR value and working voltage of C_7 must be carefully chosen
- (4) C_3 and C_4 must be close to pins VBB and GND
- (5) C_5 and C_6 must be as close as possible to pins CPN, CPP, VCP, and VBB to reduce EMC radiation
- (6) C_9 must be a ceramic capacitor to assure low ESR

13.0 Positioning Parameters

13.1 Stepping Modes

One of four possible stepping modes can be programmed:

- Half-stepping
- 1/4 micro-stepping
- 1/8 micro-stepping
- 1/16 micro-stepping

13.2 Maximum Velocity

For each stepping mode, the maximum velocity Vmax can be programmed to 16 possible values given in [Table 8](#)

The accuracy of Vmax is derived from the internal oscillator. Under special circumstances it is possible to change the Vmax parameter while a motion is ongoing. All 16 entries for the Vmax parameter are divided into four groups. When changing Vmax during a motion the application must take care that the new Vmax parameter stays within the same group.

Table 8: Maximum Velocity Selection Table

Vmax index		Vmax (full step/s)	Group	Stepping mode			
Hex	Dec			Half-stepping (half-step/s)	1/4 th micro-stepping (micro-step/s)	1/8 th micro-stepping (micro-step/s)	1/16 th micro-stepping (micro-step/s)
0	0	99	A	197	395	790	1579
1	1	136	B	273	546	1091	2182
2	2	167		334	668	1335	2670
3	3	197		395	790	1579	3159
4	4	213		425	851	1701	3403
5	5	228		456	912	1823	3647
6	6	243		486	973	1945	3891
7	7	273	C	546	1091	2182	4364
8	8	303		607	1213	2426	4852
9	9	334		668	1335	2670	5341
A	10	364		729	1457	2914	5829
B	11	395		790	1579	3159	6317
C	12	456		912	1823	3647	7294
D	13	546	D	1091	2182	4364	8728
E	14	729		1457	2914	5829	11658
F	15	973		1945	3891	7782	15564

13.3 Minimum Velocity

Once the maximum velocity is chosen, 16 possible values can be programmed for the minimum velocity Vmin. [Table 9](#) provides the obtainable values in full-step/s. The accuracy of Vmin is derived from the internal oscillator.

Table 9: Obtainable Values in Full-step/s for the Minimum Velocity

Vmin index		Vmax factor	Vmax (Full-step/s)															
Hex	Dec		A				B				C				D			
			99	136	167	197	213	228	243	273	303	334	364	395	456	546	729	973
0	0	1	99	136	167	197	213	228	243	273	303	334	364	395	456	546	729	973
1	1	1/32	3	4	5	6	6	7	7	8	8	10	10	11	13	15	19	27
2	2	2/32	6	8	10	11	12	13	14	15	17	19	21	23	27	31	42	57
3	3	3/32	9	12	15	18	19	21	22	25	27	31	32	36	42	50	65	88
4	4	4/32	12	16	20	24	26	28	30	32	36	40	44	48	55	65	88	118
5	5	5/32	15	21	26	31	32	35	37	42	46	51	55	61	71	84	111	149
6	6	6/32	18	25	31	36	39	42	45	50	55	61	67	72	84	99	134	179
7	7	7/32	21	30	36	43	46	50	52	59	65	72	78	86	99	118	156	210
8	8	8/32	24	33	41	49	52	56	60	67	74	82	90	97	113	134	179	240
9	9	9/32	28	38	47	55	59	64	68	76	84	93	101	111	128	153	202	271
A	10	10/32	31	42	51	61	66	71	75	84	93	103	113	122	141	168	225	301
B	11	11/32	34	47	57	68	72	78	83	93	103	114	124	135	156	187	248	332
C	12	12/32	37	51	62	73	79	85	91	101	113	124	135	147	170	202	271	362
D	13	13/32	40	55	68	80	86	93	98	111	122	135	147	160	185	221	294	393
E	14	14/32	43	59	72	86	93	99	106	118	132	145	158	172	198	237	317	423
F	15	15/32	46	64	78	93	99	107	113	128	141	156	170	185	214	256	340	454

- Notes**
- (1) The Vmax factor is an approximation.
 - (2) In case of motion without acceleration (**AccShape = 1**) the length of the steps = 1/Vmin. In case of accelerated motion (**AccShape = 0**) the length of the first step is shorter than 1/Vmin depending of Vmin, Vmax and Acc.

13.4 Acceleration and Deceleration

Sixteen possible values can be programmed for Acc (acceleration and deceleration between Vmin and Vmax). [Table 10](#) provides the obtainable values in full-step/s². One observes restrictions for some combination of acceleration index and maximum speed (gray cells).

The accuracy of Acc is derived from the internal oscillator.

Table 10: Acceleration and Deceleration Selection Table

Vmax (FS/s) →		99	136	167	197	213	228	243	273	303	334	364	395	456	546	729	973	
↓ Acc index		Acceleration (Full-step/s ²)																
Hex	Dec																	
0	0	49						106						473				
1	1							218						735				
2	2	1004																
3	3	3609																
4	4	6228																
5	5	8848																
6	6	11409																
7	7	13970																
8	8	16531																
9	9	14785	19092															
A	10		21886															
B	11		24447															
C	12		27008															
D	13		29570															
E	14		29570						34925									
F	15		29570						40047									

The formula to compute the number of equivalent full-step during acceleration phase is:

$$Nstep = \frac{Vmax^2 - Vmin^2}{2 \times Acc}$$

13.5 Positioning

The position programmed in commands [SetPosition](#) and [SetPositionShort](#) is given as a number of (micro)steps. According to the chosen stepping mode, the position words must be aligned as described in Table 11. When using command [SetPositionShort](#) or [GotoSecurePosition](#), data is automatically aligned.

Table 11: Position Word Alignment

Stepping mode	Position word: Pos [15:0]																Shift
1/16 th	S	B14	B13	B12	B11	B10	B9	B8	B7	B6	B5	B4	B3	B2	B1	LSB	No shift
1/8 th	S	B13	B12	B11	B10	B9	B8	B7	B6	B5	B4	B3	B2	B1	LSB	0	1-bit left ⇔ ×2
1/4 th	S	B12	B11	B10	B9	B8	B7	B6	B5	B4	B3	B2	B1	LSB	0	0	2-bit left ⇔ ×4
Half-stepping	S	B11	B10	B9	B8	B7	B6	B5	B4	B3	B2	B1	LSB	0	0	0	3-bit left ⇔ ×8
PositionShort	S	S	S	B9	B8	B7	B6	B5	B4	B3	B2	B1	LSB	0	0	0	No shift
SecurePosition	S	B9	B8	B7	B6	B5	B4	B3	B2	B1	LSB	0	0	0	0	0	No shift

Notes

- (1) LSB: Least Significant Bit
- (2) S: Sign bit

13.5.1. Position Ranges

A position is coded by using the binary two's complement format. According to the positioning commands used and to the chosen stepping mode, the position range will be as shown in Table 12.

Table 12: Position Range

Command	Stepping mode	Position range	Full range excursion	Number of bits
SetPosition	Half-stepping	-4096 to +4095	8192 half-steps	13
	1/4 th micro-stepping	-8192 to +8191	16384 micro-steps	14
	1/8 th micro-stepping	-16384 to +16383	32768 micro-steps	15
	1/16 th micro-stepping	-32768 to +32767	65536 micro-steps	16
SetPositionShort	Half-stepping	-1024 to +1023	2048 half-steps	11

When using the command [SetPosition](#), although coded on 16 bits, the position word will have to be shifted to the left by a certain number of bits, according to the stepping mode.

13.5.2. Secure Position

A secure position can be programmed. It is coded in 11-bits, thus having a lower resolution than normal positions, as shown in Table 13. See also command [GotoSecurePosition](#) and [LIN lost behavior](#).

Table 13: Secure Position

Stepping mode	Secure position resolution
Half-stepping	4 half-steps
1/4 th micro-stepping	8 micro-steps (1/4 th)
1/8 th micro-stepping	16 micro-steps (1/8 th)
1/16 th micro-stepping	32 micro-steps (1/16 th)

Important Note

- (1) The secure position is disabled in case the programmed value is the reserved code "1000000000" (0x400 or most negative position).
- (2) The resolution of the secure position is limited to 9 bit at start-up. The OTP register is copied in RAM as illustrated below. SecPos1 and SecPos0 = 0

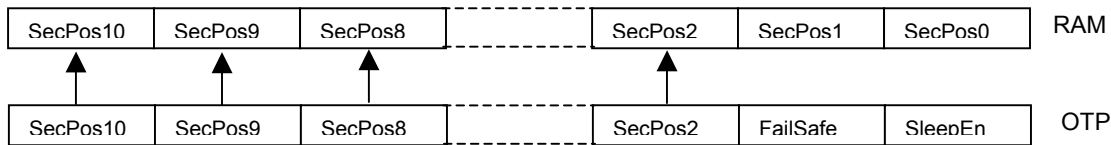

13.5.3. Shaft

A shaft bit which can be programmed in [OTP](#) or with command [SetMotorParam](#), defines whether a positive motion is a clockwise or counter-clockwise rotation (an outer or an inner motion for linear actuators):

- Shaft = 0 ⇒ MOTXP is used as positive pin of the X coil, while MOTXN is the negative one.
- Shaft = 1 ⇒ opposite situation

14.0 Structural Description

See also the [Block Diagram](#) in Figure 1.

14.1 Stepper Motordriver

The Motordriver receives the control signals from the control logic. The main features are:

- Two H-bridges designed to drive a stepper motor with two separated coils. Each coil (X and Y) is driven by one H-bridge, and the driver controls the currents flowing through the coils. The rotational position of the rotor, in unloaded condition, is defined by the ratio of current flowing in X and Y. The torque of the stepper motor when unloaded is controlled by the magnitude of the currents in X and Y.
- The control block for the H-bridges including the PWM control, the synchronous rectification, and the internal current sensing circuitry.
- The charge pump to allow driving of the H-bridges' high side transistors.
- Two pre-scale 4-bit DAC's to set the maximum magnitude of the current through X and Y.
- Two DAC's to set the correct current ratio through X and Y.

Battery voltage monitoring is also performed by this block, which provides needed information to the control logic part. The same applies for detection and reporting of an electrical problem that could occur on the coils or the charge pump.

14.2 Control Logic (Position Controller and Main control)

The control logic block stores the information provided by the LIN interface (in a RAM or an OTP memory) and digitally controls the positioning of the stepper motor in terms of speed and acceleration, by feeding the right signals to the motordriver state machine.

It will take into account the successive positioning commands to properly initiate or stop the stepper motor in order to reach the set point in a minimum time.

It also receives feedback from the motordriver part in order to manage possible problems and decide on internal actions and reporting to the LIN interface.

14.3 Motion Detection

Motion detection is based on the back emf generated internally in the running motor. When the motor is blocked, e.g. when it hits the end-position, the velocity and as a result also the generated back emf, is disturbed. The AMIS-30623 senses the back emf, calculates a moving average and compares the value with two independent threshold levels. If the back emf disturbance is bigger than the set threshold, the running motor is stopped.

14.4 LIN Interface

The LIN interface implements the physical layer and the MAC and LLC layers according to the OSI reference model. It provides and gets information to and from the control logic block, in order to drive the stepper motor, to configure the way this motor must be driven, or to get information such as actual position or diagnosis (temperature, battery voltage, electrical status...) and pass it to the LIN master node.

14.5 Miscellaneous

The AMIS-30623 also contains the following:

- An internal oscillator, needed for the LIN protocol handler as well as the control logic and the PWM control of the motordriver.
- An internal trimmed voltage source for precise referencing.
- A protection block featuring a thermal shutdown and a power-on-reset circuit.
- A 5V regulator (from the battery supply) to supply the internal logic circuitry.

15.0 Functions Description

This chapter describes the following functional blocks in more detail:

- Position controller
- Main control and register, OTP memory + ROM
- Motordriver

The Motion detection and LIN controller are discussed in separate chapters.

15.1 Position Controller

15.1.1. Positioning and Motion Control

A positioning command will produce a motion as illustrated in Figure 8. A motion starts with an acceleration phase from minimum velocity (V_{min}) to maximum velocity (V_{max}), and ends with a symmetrical deceleration. This is defined by the control logic according to the position required by the application and the parameters programmed by the application during configuration phase. The current in the coils is also programmable.

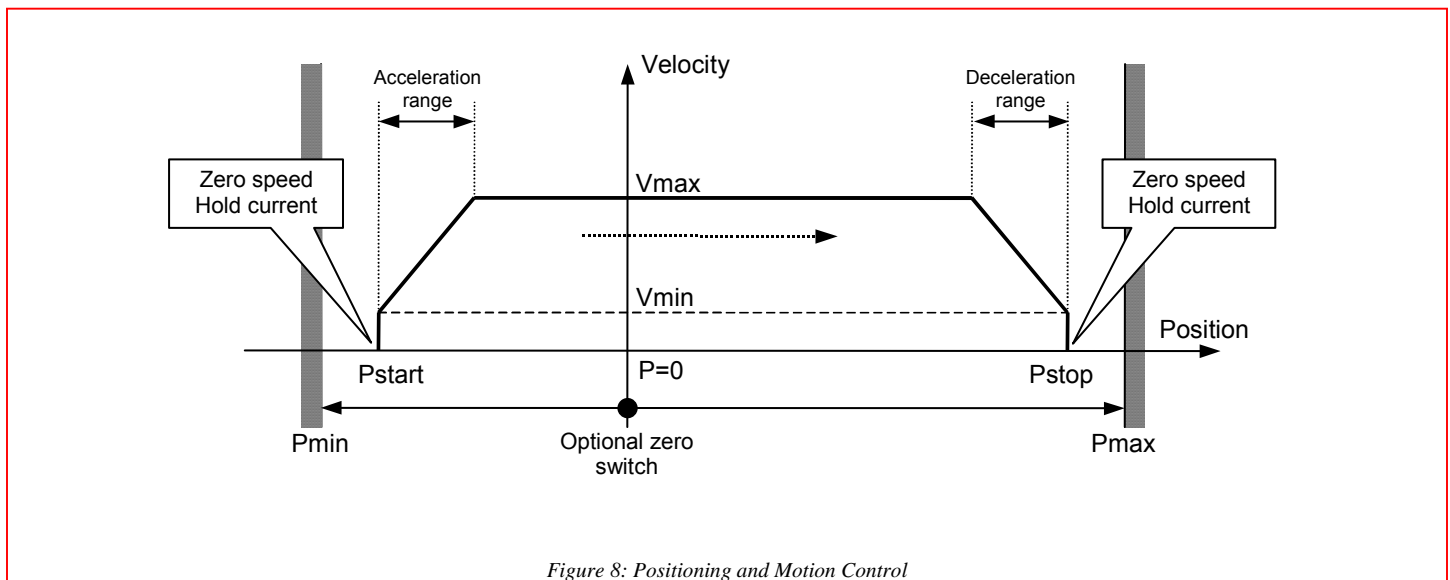

Figure 8: Positioning and Motion Control

Table 14: Position Related Parameters

Parameter	Reference
$P_{max} - P_{min}$	See Positioning
Zero speed Hold Current	See Ihold
Maximum current	See Irun
Acceleration and deceleration	See Acceleration and Deceleration
V_{min}	See Minimum Velocity
V_{max}	See Maximum Velocity

Different positioning examples are shown in the table below.

Table 15: Positioning Examples

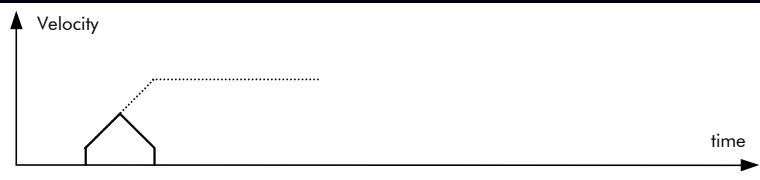
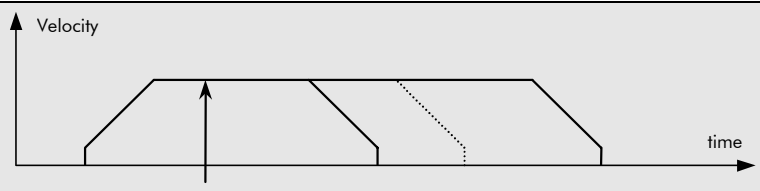
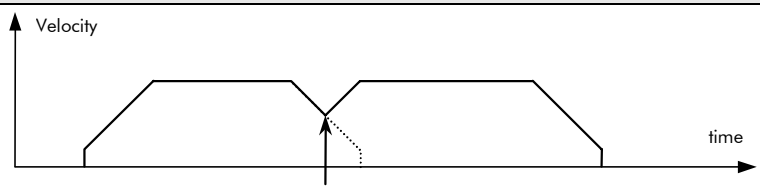
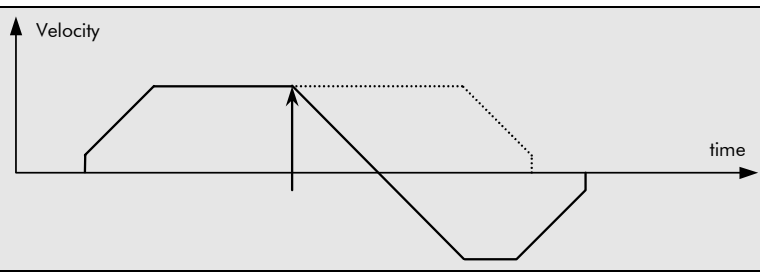
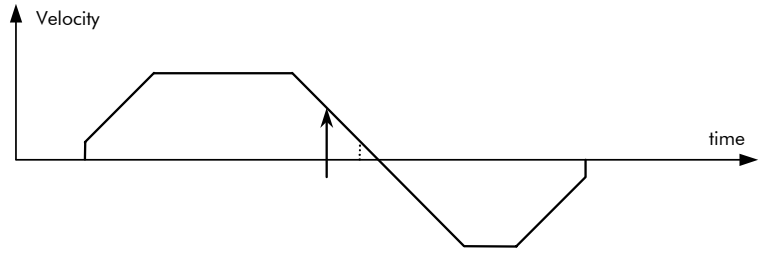
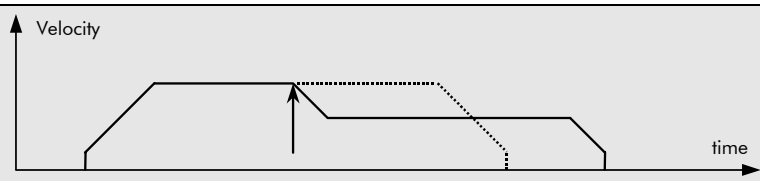
Positioning Examples	
Short motion	
New positioning command in same direction, shorter or longer, while a motion is running at maximum velocity	
New positioning command in same direction while in deceleration phase <i>Note:</i> there is no wait time between the deceleration phase and the new acceleration phase.	
New positioning command in reverse direction while motion is running at maximum velocity	
New positioning command in reverse direction while in deceleration phase	
New velocity programming while motion is running	

15.1.2. Dual Positioning

A [SetDualPosition](#) command allows the user to perform a positioning using two different velocities. The first motion is done with the specified V_{min} and V_{max} velocities in the [SetDualPosition](#) command, with the acceleration (deceleration) parameter already in RAM, to a position $Pos1[15:0]$ also specified in [SetDualPosition](#).

Then a second relative motion to a position $Pos1[15:0] + Pos2[15:0]$ is done at the specified V_{min} velocity in the [SetDualPosition](#) command (no acceleration). Once the second motion is achieved, the $ActPos$ register is reset to zero, whereas $TagPos$ register is not changed.

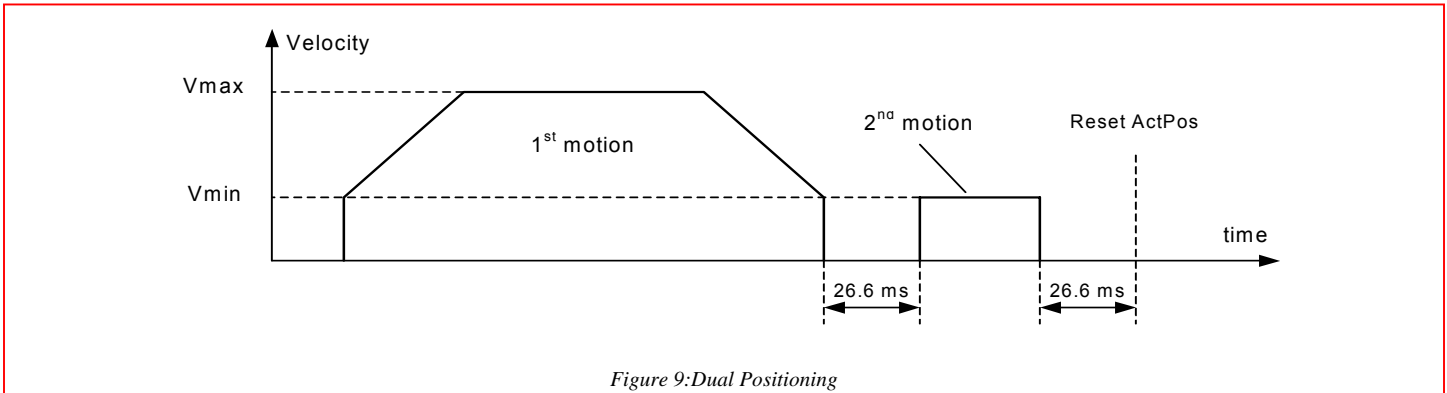

Figure 9: Dual Positioning

Remark: This operation cannot be interrupted or influenced by any further command unless the occurrence of the conditions driving to a [motor shutdown](#) or by a [HardStop](#) command. Sending a [SetDualPosition](#) command while a motion is already ongoing is not recommended.

Notes

- (0) The [priority encoder](#) is describing the management of states and commands. All notes below are to be considered illustrative.
- (1) The last [SetPosition\(Short\)](#) command issued during an [DualPosition](#) sequence will be kept in memory and executed afterwards. This applies also for the commands [Sleep](#) and [SetMotorParam](#) and [GotoSecurePosition](#).
- (2) Commands such as [GetActualPos](#) or [GetStatus](#) will be executed while a [Dual Positioning](#) is running. This applies also for a dynamic [ID assignment](#) LIN frame
- (3) A [DualPosition](#) sequence starts by setting $TagPos$ register to $SecPos$ value, provided secure position is enabled otherwise $TagPos$ is reset to zero.
- (4) The acceleration/deceleration value applied during a [DualPosition](#) sequence is the one stored in RAM before the [SetDualPosition](#) command is sent. The same applies for $Shaft$ bit, but not for $Irun$, $Ihold$ and $StepMode$, which can be changed during the [Dual Positioning](#) sequence.
- (5) The $Pos1$, $Pos2$, V_{max} and V_{min} values programmed in a [SetDualPosition](#) command apply only for this sequence. All further positioning will use the parameters stored in RAM (programmed for instance by a former [SetMotorParam](#) command).
- (6) Commands [ResetPosition](#), [SetDualPosition](#), and [SoftStop](#) will be ignored while a [DualPosition](#) sequence is ongoing, and will not be executed afterwards.
- (7) A [SetMotorParam](#) command should not be sent during a [SetDualPosition](#) sequence.
- (8) If for some reason $ActPos$ equals $Pos1[15:0]$ at the moment the [SetDualPosition](#) command is issued, the circuit will enter in deadlock state. Therefore, the application should check the actual position by a [GetPosition](#) or a [GetFullStatus](#) command prior to send the [SetDualPosition](#) command.

15.1.3. Position Periodicity

Depending on the stepping mode the position can range from -4096 to $+4095$ in half-step to -32768 to $+32767$ in $1/16^{th}$ microstepping mode. One can project all these positions lying on a circle. When executing the command [SetPosition](#), the position controller will set the movement direction in such a way that the traveled distance is minimum.

The figure below illustrates that the moving direction going from $ActPos = +30000$ to $TagPos = -30000$ is clockwise.

If a counter clockwise motion is required in this example, several consecutive [SetPosition](#) commands can be used. One could also use for larger movements the command `<RunVelocity>`.

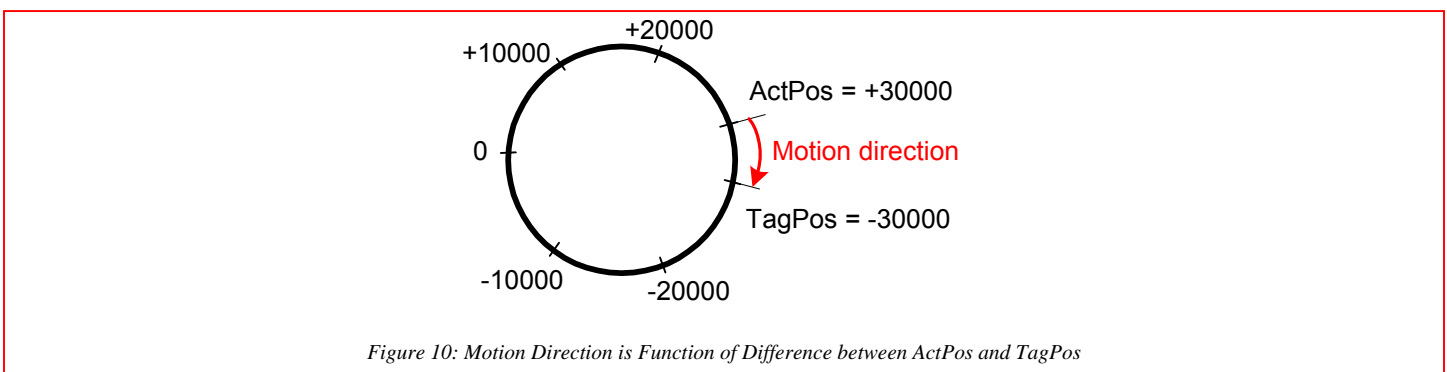

Figure 10: Motion Direction is Function of Difference between $ActPos$ and $TagPos$

15.1.4. Hardwired Address HW2

In [Figure 11](#) a simplified schematic diagram is shown of the HW2 comparator circuit.

The HW2 pin is sensed via 2 switches. The DriveHS and DriveLS control lines are alternatively closing the top and bottom switch connecting HW2 pin with a current to resistor converter. Closing S_{TOP} (DriveHS = 1) will sense a current to GND. In that case the top $I \rightarrow R$ convertor output is low, via the closed passing switch S_{PASS_T} this signal is fed to the "R" comparator which output HW2_Cmp is high. Closing bottom switch S_{BOT} (DriveLS = 1) will sense a current to VBAT. The corresponding $I \rightarrow R$ converter output is low and via S_{PASS_B} fed to the comparator. The output HW2_Cmp will be high.

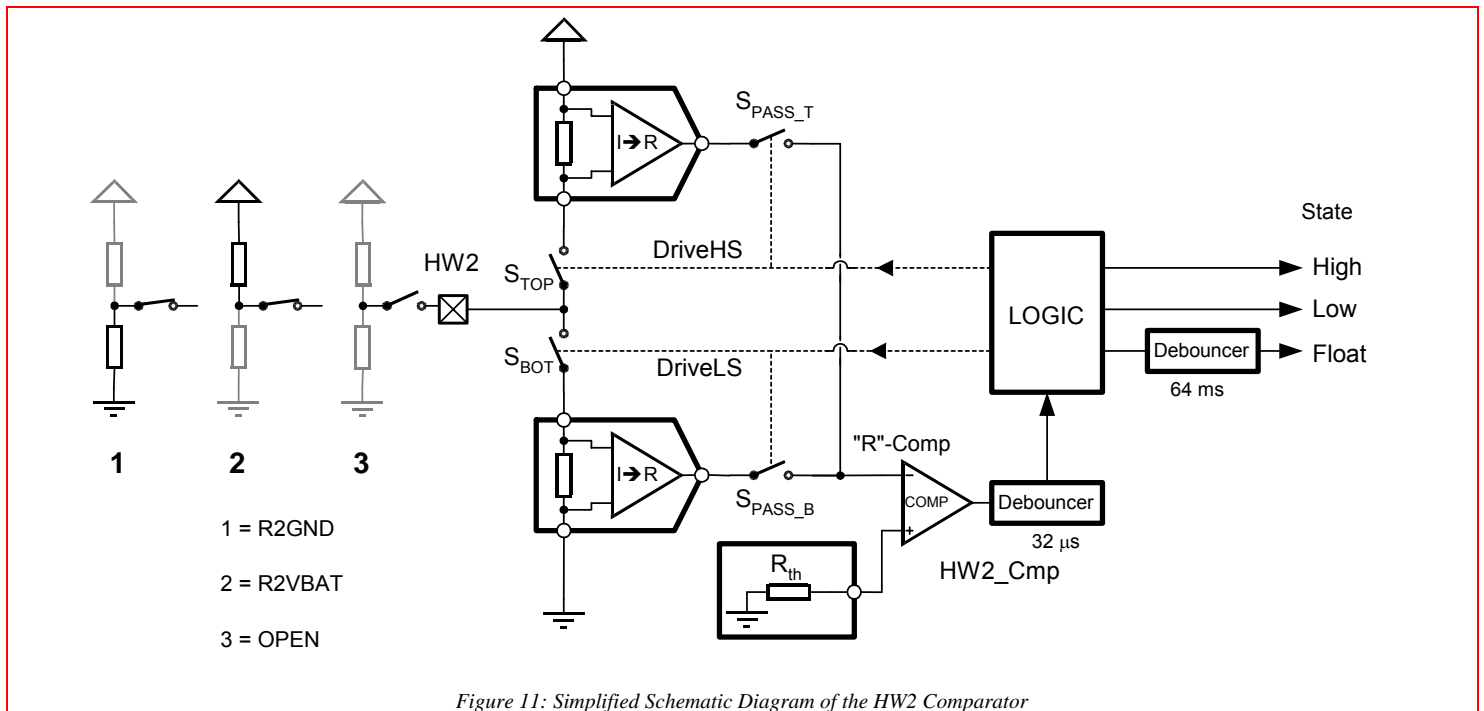

Figure 11: Simplified Schematic Diagram of the HW2 Comparator

3 cases can be distinguished (see also Figure 11):

- HW2 is connected to ground: R2GND or drawing 1
- HW2 is connected to VBAT: R2VBAT or drawing 2
- HW2 is floating: OPEN or drawing 3

Table 16: State Diagram of the HW2 Comparator

Previous State	DriveLS	DriveHS	HW2_Cmp	New State	Condition	Drawing
Float	1	0	0	Float	R2GND or OPEN	1 or 3
Float	1	0	1	High	R2VBAT	2
Float	0	1	0	Float	R2VBAT or OPEN	2 or 3
Float	0	1	1	Low	R2GND	1
Low	1	0	0	Low	R2GND or OPEN	1 or 3
Low	1	0	1	High	R2VBAT	2
Low	0	1	0	Float	R2VBAT or OPEN	2 or 3
Low	0	1	1	Low	R2GND	1
High	1	0	0	Float	R2GND or OPEN	1 or 3
High	1	0	1	High	R2VBAT	2
High	0	1	0	High	R2VBAT or OPEN	2 or 3
High	0	1	1	Low	R2GND	1

The logic is controlling the correct sequence in closing the switches and in interpreting the 32 μ s debounced HW2_Cmp output accordingly. The output of this small state-machine is corresponding to:

- High or address = 1
- Low or address = 0
- Floating

As illustrated in [Table 16](#) the state is depending on the previous state, the condition of the 2 switch controls (DriveLS and DriveHS) and the output of HW2_Cmp. Figure 12 is showing an example of a practical case where a connection to VBAT is interrupted.

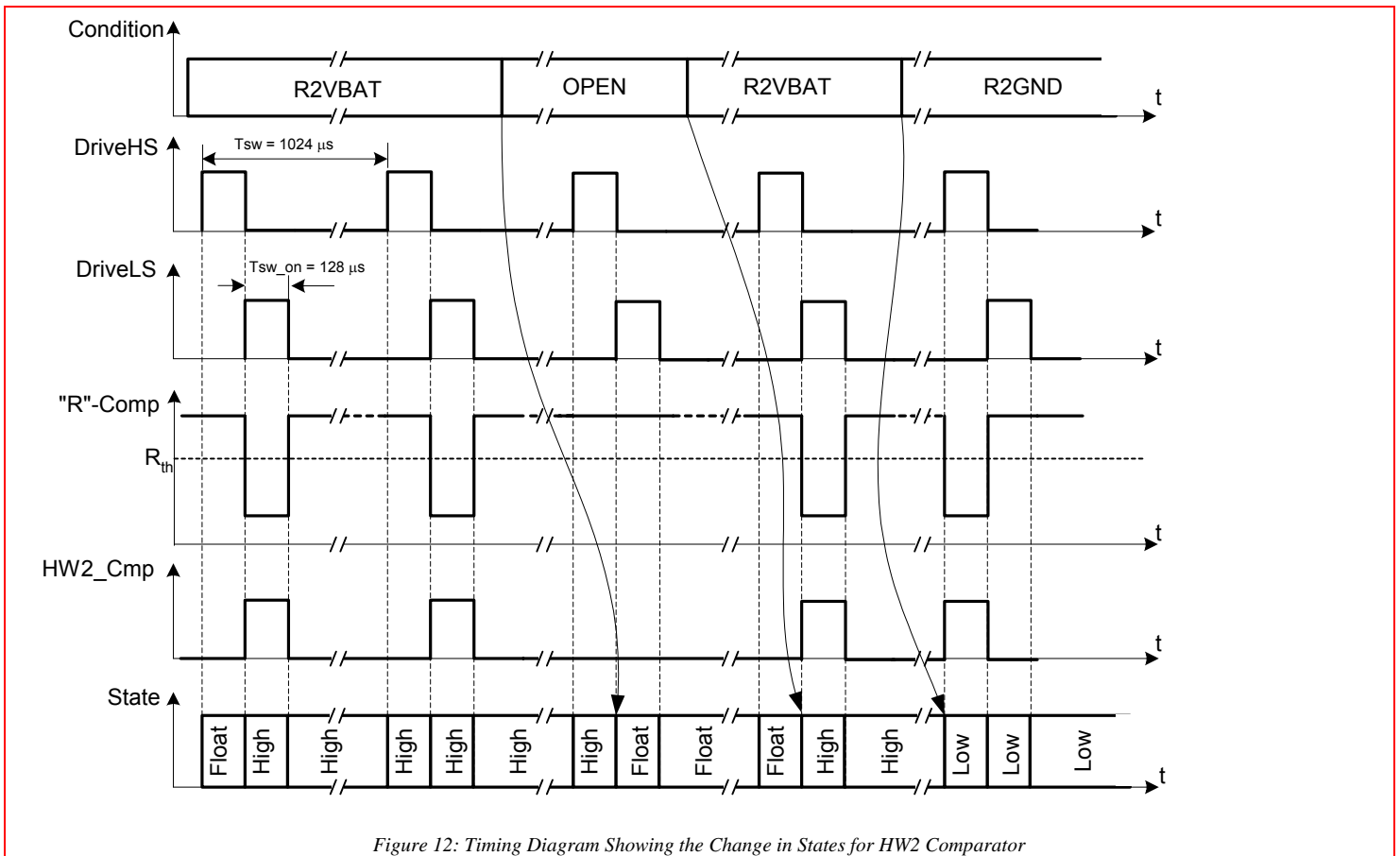

Figure 12: Timing Diagram Showing the Change in States for HW2 Comparator

R2VBAT

A resistor is connected between VBAT and HW2. Every 1024 μs S_{BOT} is closed a current is sensed, the output of the I → R converter is low and the HW2_Cmp output is high. Assuming the previous state was floating, the internal LOGIC will interpret this as a change of state and the new state will be High. (see also [Table 16](#)). The next time S_{BOT} is closed the same conditions are observed. The previous state was High, so based on [Table 16](#) the new state remains unchanged. This high state will be interpreted as HW2 address = 1

OPEN

In case the HW2 connection is lost (broken wire, bad contact in connector) the next time S_{BOT} is closed this will be sensed. There will be no current, the output of the corresponding I → R converter is High and the HW2_Cmp will be low. The previous state was High. Based in [Table 16](#) one can see that the state changes to float. This will trigger a motion to secure position after a debounce time of 64 ms. This prevents false triggering in case of false micro interruptions of the power supply. See also [Electrical transient conduction along supply lines](#)

R2GND

If a resistor is connected between HW2 and the GND, a current is sensed every 1024 μs when S_{TOP} is closed. The output of the top I → R converter is low and as a result the HW2_Cmp output switches to High. Again based on the stated diagram in Table 1 one can see that the state will change to Low. This low state will be interpreted as HW2 address = 0.

15.1.5. External Switch SWI

As illustrated in Figure 13 the SWI comparator is almost identical to HW2. The major difference is in the limited number of states. Only open or closed is recognised leading to respectively ESW = 0 and ESW = 1.

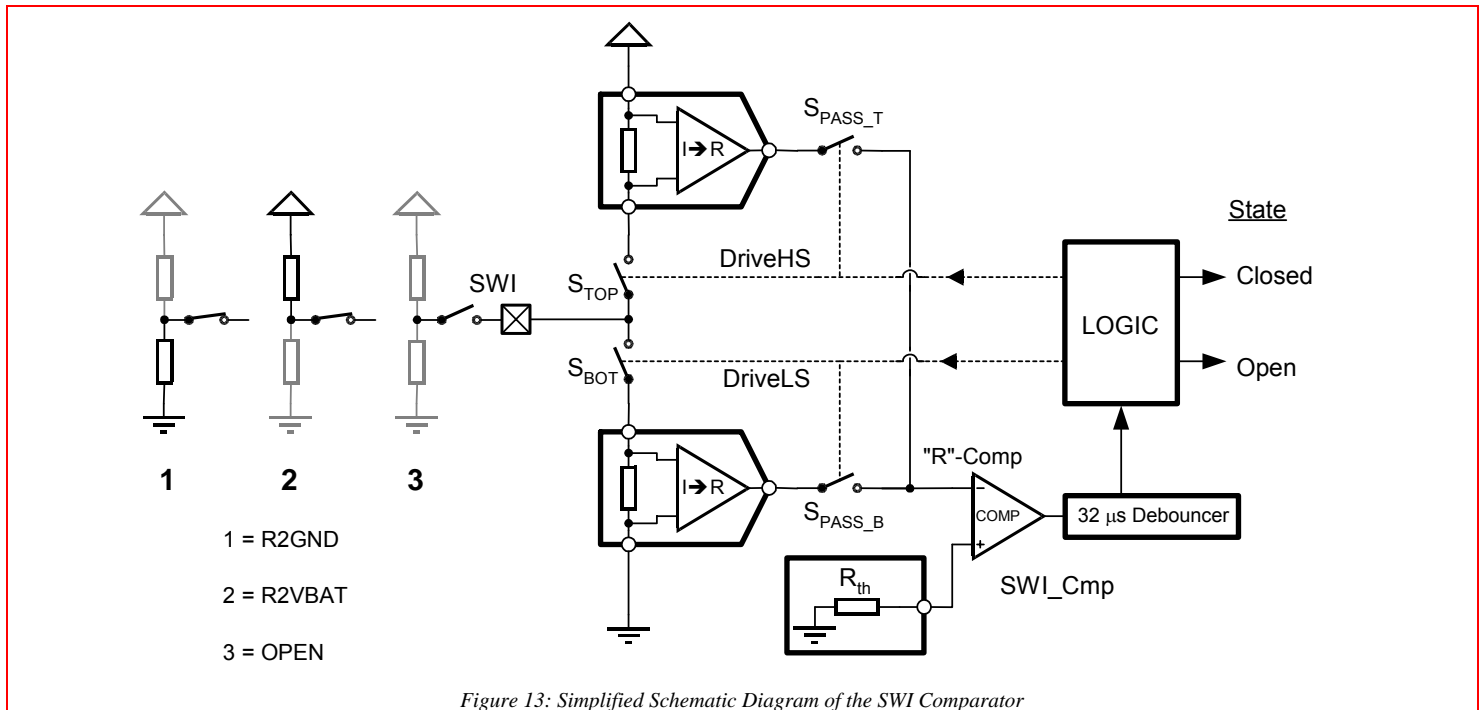

As illustrated in Figure 15 a change in state is always synchronised with DriveHS or DriveLS. The same synchronisation is valid for updating the internal position register. This means that after every current pulse (or closing of S_{TOP} or S_{BOT}) the state of position switch together with the corresponding position is memorised.

Using the GetActualPos commands reads back the ActPos register and the status of ESW. In this way the master node may get synchronous information about the state of the switch together with the position of the motor. See Figure 14 below:

Reading Frame									
Byte	Content	Structure							
		Bit 7	Bit 6	Bit 5	Bit 4	Bit 3	Bit 2	Bit 1	Bit 0
0	Identifier	*	*	1	0	ID3	ID2	ID1	ID0
1	Data 1	ESW	AD [6:0]						
2	Data 2	ActPos [15:8]							
3	Data 3	ActPos [7:0]							
4	Data 4	VddReset	StepLoss	ElDef	UV2	TSD	TW	Tinfo [1:0]	

Figure 14: GetActualPos LIN commando

Important remark. Every 512µs this information is refreshed.

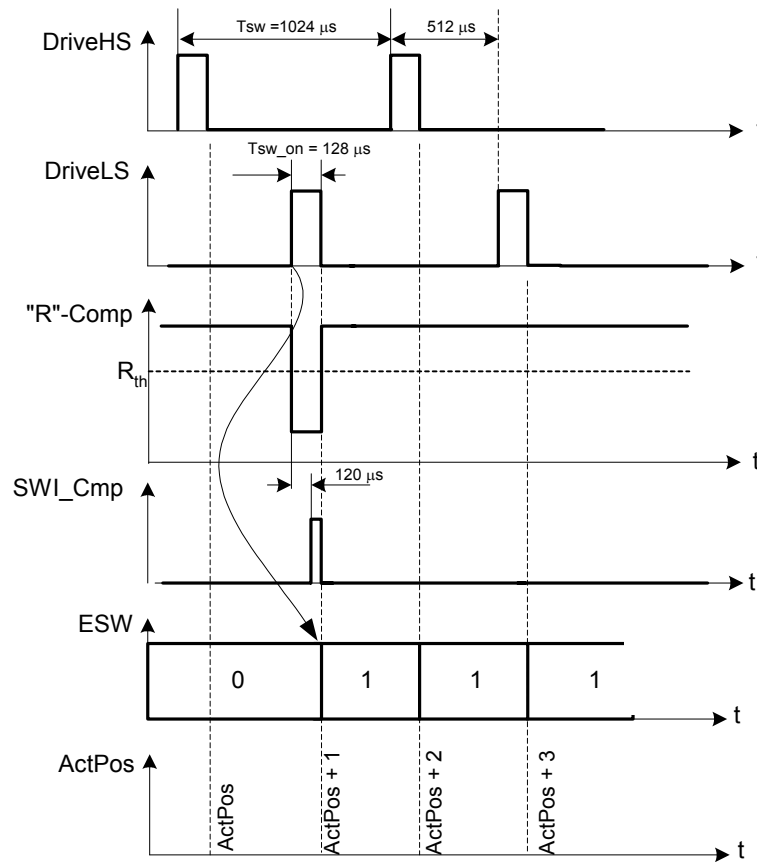

Figure 15: Timing diagram showing the change in states for SWI comparator

15.2 Main Control and Register, OTP memory + ROM

15.2.1. Power-up Phase

Power up phase of the AMIS-30623 will not exceed 10ms. After this phase, the AMIS-30623 is in shutdown mode, ready to receive LIN messages and execute the associated commands. After power-up, the registers and flags are in the reset state, some of them being loaded with the OTP memory content (see [Table 22: RAM registers](#)).

15.2.2. Reset State

After power-up, or after a reset occurrence (e.g. a micro cut on pin VBB has made Vdd to go below VddReset level), the H-bridges will be in high impedance mode, and the registers and flags will be in a predetermined position. This is documented in [Table 22: RAM registers](#) and [Table 23: Flags Table](#).

15.2.3. Soft Stop

A soft stop is an immediate interruption of a motion, but with a deceleration phase. At the end of this action, the register TagPos is loaded with the value contained in register ActPos to avoid an attempt of the circuit to achieve the motion (see [Table 22: RAM registers](#)). The circuit is then ready to execute a new positioning command, provided thermal and electrical conditions allow for it.

15.2.4. Sleep Mode

When entering sleep mode, the stepper-motor can be driven to its secure position. After which, the circuit is completely powered down, apart from the LIN receiver, which remains active to detect dominant state on the bus. In case sleep mode is entered while a motion is ongoing, a transition will occur towards secure position as described in [Positioning and Motion Control](#) provided `SecPos` is enabled. Otherwise, `SoftStop` is performed.

Sleep mode can be entered in the following cases:

- The circuit receives a LIN frame with identifier **0x3C** and first data byte containing **0x00**, as required by LIN specification rev 1.3. See [Sleep](#)
- In case the `SleepEn` bit = 1 and the LIN bus remains inactive (or is lost) during more than 25000 time slots (1.30s at 19.2kbit/s), a time-out signal switches the circuit to sleep mode. See also

The circuit will return to normal mode if a valid LIN frame is received while entering the sleep mode (this valid frame can be addressed to another slave).

15.2.5. Thermal Shutdown Mode

When thermal shutdown occurs, the circuit performs a `SoftStop` command and goes to Motor shutdown mode (see below).

15.2.6. Temperature Management

The AMIS-30623 monitors temperature by means of two thresholds and one shutdown level, as illustrated in the state diagram below. The only condition to reset flags `<TW>` and `<TSD>` (respectively thermal warning and thermal shutdown) is to be at a temperature lower than `Ttw` and to get the occurrence of a [GetStatus](#) or a [GetFullStatus](#) LIN frame.

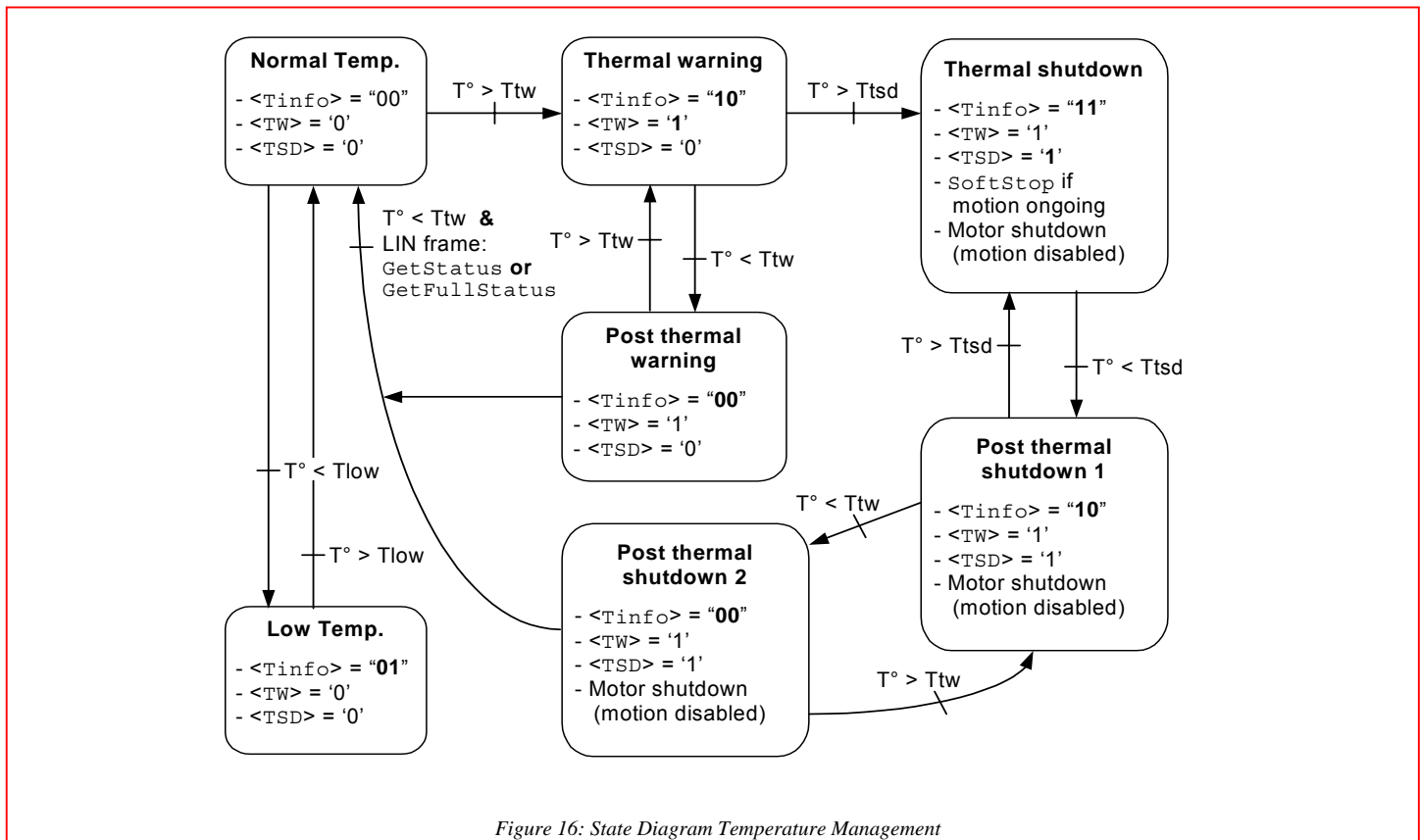

Figure 16: State Diagram Temperature Management

15.2.7. Autarkic functionality in under-voltage condition

Battery voltage management

The AMIS-30623 monitors the battery voltage by means of one threshold and one shutdown level, as illustrated in the state diagram below. The only condition to reset flags `<UV2>` and `<StepLoss>` is to recover a battery voltage higher than UV1 and to receive a [GetStatus](#) or a [GetFullStatus](#) command.

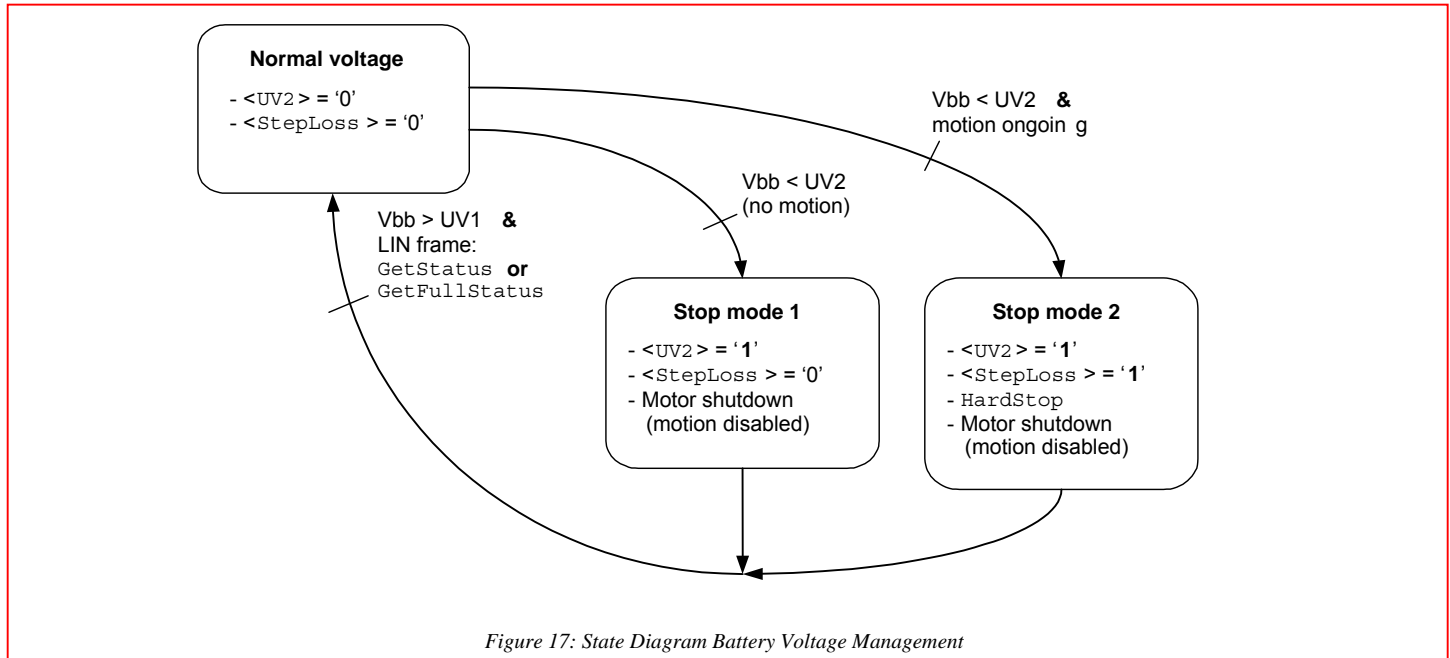

Figure 17: State Diagram Battery Voltage Management

Autarkic function

In **Stop mode 1** the motor is put in shutdown state. The `<UV2>` flag is set. In case $V_{bb} > UV1$ AMIS-30623 accepts updates of the target position by means of the reception of [SetPosition](#), [SetPositionShort](#), [SetPosParam](#) and [GotoSecurePosition](#) commands, even if the `<UV2>` flag is NOT prior cleared.

In **Stop mode 2** the motor is stopped immediately and put in shutdown state. The `<UV2>` and `<Steploss>` flags are set. In case $V_{bb} > UV1$ AMIS-30623 autonomously resumes the motion to the original target position using the stored motor parameters (minimum and maximum velocity, acceleration, step-mode, run- and hold current) in case no RAM reset occurred.

The flags are only cleared after receiving a [GetStatus](#) or [GetFullStatus](#) command.

Updates of the target position by means of the reception of [SetPosition](#), [SetPositionShort](#), [SetPosParam](#) and [GotoSecurePosition](#) commands is accepted, even if the `<UV2>` and `<Steploss>` flags are NOT prior cleared.

Important notes:

1. In the case of Stop mode 2 care needs to be taken because the accumulated steploss can cause a significant deviation between physical and stored actual position.
2. The [SetDualPosition](#) command will only be executed after clearing the `<UV2>` and `<Steploss>` flags.
3. RAM reset occurs when $V_{dd} < V_{ddReset}$ (digital Power On Reset level)
4. The Autarkic function remains active as long as $V_{dd} > V_{ddReset}$

Logical implementation Autarkic function

The logic uses the `<UV2>`, `<CPFail>` and `<Steploss>` signal NOT the state.

The state is set one clock after the signal and would therefore slow down the reaction time. Also the state can only be cleared after a [GetStatus](#) or [GetFullStatus](#) command which prevents the autonomous function.

Only `<UV2>` and `<CPFail>` are applicable for finishing the motion to the original target position:

`<UV2>` needs to be cleared to leave the Shutdown State

`<CPFail>` needs to be cleared to avoid a new `HardStop` after entering the `GotoPos` state

The <StepLoss> signal is used to block successive motions. Also this signal will be cleared after $V_{bb} > UV1$, making updates of TagPos possible.

The implementation is illustrated in the state diagram below.

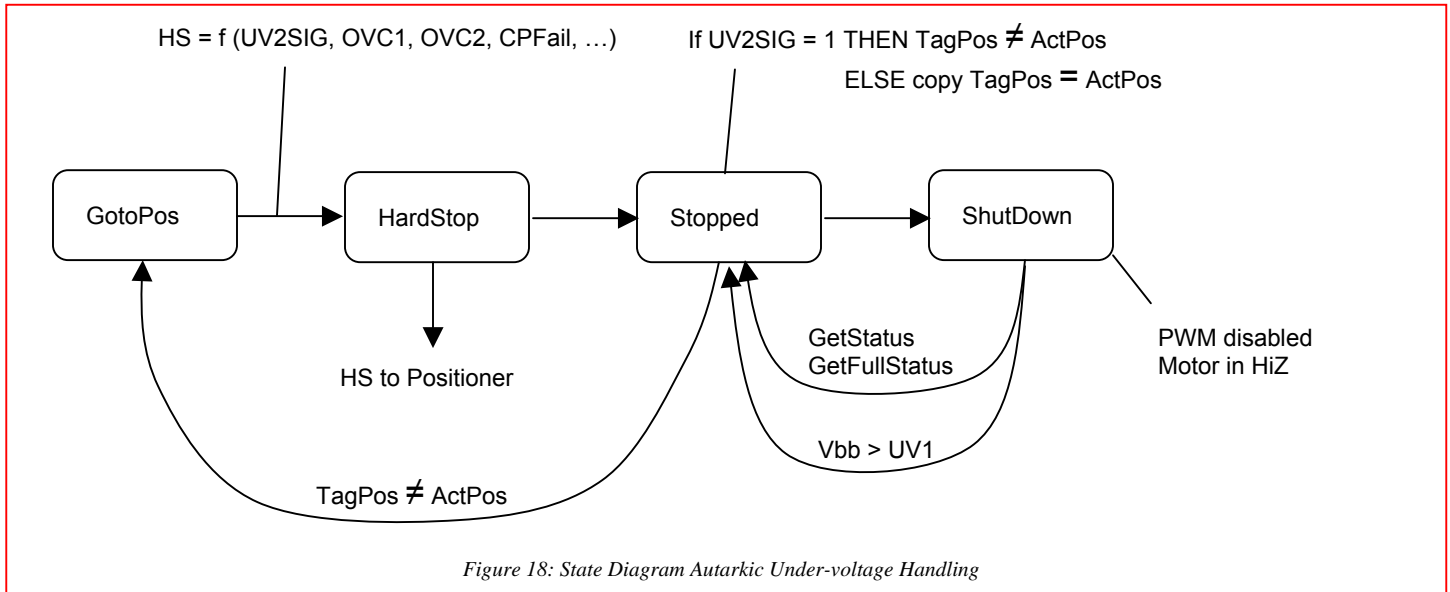

Figure 18: State Diagram Autarkic Under-voltage Handling

In **Stop mode 1** AMIS-30623 is in the Stopped state. Because $V_{bb} < UV2$ it enters the ShutDown state. Once $V_{bb} > UV1$ the Stopped state will be entered again.

In **Stop mode 2** AMIS-30623 is in the GotoPos state. Because $V_{bb} < UV2$ the UV2SIG is set and the HardStop state is entered. After the hardstop motion is finished (HS to Positioner) it enters the Stopped state. UV2SIG = 1 so the TagPos is not copied in Actpos, and the shutdown stated is entered. Once $V_{bb} > UV1$ the Stopped state will be entered again and because TagPos = Actpos C623 moves to GotoPos again. <UV2SIG>, <CPFail> and <StepLoss> are cleared when $V_{bb} > UV1$ so HardStop is not entered again.

15.2.8. OTP register

OTP Memory Structure

The table below shows how the parameters to be stored in the OTP memory are located.

Table 17: OTP Memory Structure

Address	Bit 7	Bit 6	Bit 5	Bit 4	Bit 3	Bit 2	Bit 1	Bit 0
0x00	OSC3	OSC2	OSC1	OSC0	IREF3	IREF2	IREF1	IREF0
0x01	EnableLIN	TSD2	TSD1	TSD0	BG3	BG2	BG1	BG0
0x02	AbsThr3	AbsThr2	AbsThr1	AbsThr0	PA3	PA2	PA1	PA0
0x03	Irun3	Irun2	Irun1	Irun0	Ihold3	Ihold2	Ihold1	Ihold0
0x04	Vmax3	Vmax2	Vmax1	Vmax0	Vmin3	Vmin2	Vmin1	Vmin0
0x05	SecPos10	SecPos9	SecPos8	Shaft	Acc3	Acc2	Acc1	Acc0
0x06	SecPos7	SecPos6	SecPos5	SecPos4	SecPos3	SecPos2	Failsafe	SleepEn
0x07	DelThr3	DelThr2	DelThr1	DelThr0	StepMode1	StepMode0	LOCKBT	LOCKBG

Parameters stored at address 0x00 and 0x01 and bit LOCKBT are already programmed in the OTP memory at circuit delivery. They correspond to the calibration of the circuit and are just documented here as an indication.

Each OPT bit is at '0' when not zapped. Zapping a bit will set it to '1'. Thus only bits having to be at '1' must be zapped. Zapping of a bit already at '1' is disabled. Each OTP byte will be programmed separately (see command [SetOTPparam](#)). Once OTP programming is completed, bit LOCKBG can be zapped, to disable future zapping, otherwise any OTP bit at '0' could still be zapped by using a [SetOTPparam](#) command.

Table 18: OTP Overwrite Protection

Lock bit	Protected bytes
LOCKBT (factory zapped before delivery)	0x00 to 0x01
LOCKBG	0x00 to 0x07

The command used to load the application parameters via the LIN bus in the RAM prior to an OTP Memory programming is [SetMotorParam](#). This allows for a functional verification before using a [SetOTPparam](#) command to program and zap separately one OTP memory byte. A [GetOTPparam](#) command issued after each [SetOTPparam](#) command allows to verify the correct byte zapping.

Note: zapped bits will really be "active" after a [GetOTPparam](#) or a [ResetToDefault](#) command or after a power-up.

Application parameters stored in OTP Memory

Except for the physical address $PA[3:0]$ these parameters, although programmed in a non-volatile memory can still be overridden in RAM by a LIN writing operation.

PA[3:0] In combination with $HW[2:0]$ it forms the physical address $AD[6:0]$ of the stepper-motor. Up to 128 Stepper-motors can theoretically be connected to the same LIN bus

AbsThr[3:0] Absolute and Relative threshold used for the motion detection

Index	AbsThr			AbsThr level (V)
0	0	0	0	Disable
1	0	0	0	0.5
2	0	0	1	1.0
3	0	0	1	1.5
4	0	1	0	2.0
5	0	1	0	2.5
6	0	1	1	3.0
7	0	1	1	3.5
8	1	0	0	4.0
9	1	0	0	4.5
A	1	0	1	5.0
B	1	0	1	5.5
C	1	1	0	6.0
D	1	1	0	6.5
E	1	1	1	7.0
F	1	1	1	7.5

DelThr[3:0] Absolute and Relative threshold used for the motion detection

Index	DelThr			DelThr level (V)
0	0	0	0	Disable
1	0	0	0	0.25
2	0	0	1	0.50
3	0	0	1	0.75
4	0	1	0	1.00
5	0	1	0	1.25
6	0	1	1	1.50
7	0	1	1	1.75
8	1	0	0	2.00
9	1	0	0	2.25
A	1	0	1	2.50
B	1	0	1	2.75
C	1	1	0	3.00
D	1	1	0	3.25
E	1	1	1	3.50
F	1	1	1	3.75

Irun [3:0] Current amplitude value to be fed to each coil of the stepper-motor. The table below provides the 16 possible values for IRUN.

Index	Irun				Run current (mA)
0	0	0	0	0	59
1	0	0	0	1	71
2	0	0	1	0	84
3	0	0	1	1	100
4	0	1	0	0	119
5	0	1	0	1	141
6	0	1	1	0	168
7	0	1	1	1	200
8	1	0	0	0	238
9	1	0	0	1	283
A	1	0	1	0	336
B	1	0	1	1	400
C	1	1	0	0	476
D	1	1	0	1	566
E	1	1	1	0	673
F	1	1	1	1	800

Ihold [3:0] Hold current for each coil of the stepper-motor. The table below provides the 16 possible values for IHOLD.

Index	Ihold				Hold current (mA)
0	0	0	0	0	59
1	0	0	0	1	71
2	0	0	1	0	84
3	0	0	1	1	100
4	0	1	0	0	119
5	0	1	0	1	141
6	0	1	1	0	168
7	0	1	1	1	200
8	1	0	0	0	238
9	1	0	0	1	283
A	1	0	1	0	336
B	1	0	1	1	400
C	1	1	0	0	476
D	1	1	0	1	566
E	1	1	1	0	673
F	1	1	1	1	0

StepMode Indicator of stepping mode to be used.

StepMode	Step mode	
0	0	1/2 stepping
0	1	1/4 stepping
1	0	1/8 stepping
1	1	1/16 stepping

shaft Indicator of Reference Position. If *shaft* = '0', the reference position is the maximum inner position, whereas if *shaft* = '1', the reference position is the maximum outer position

SecPos [10:0] Secure Position of the stepper-motor. This is the position to which the motor is driven in case of a LIN communication loss or when the LIN error counter overflows. If *SecPos* [10:0] = "100 0000 0000", this means that Secure Position is disabled, e.g. the stepper-motor will be kept in the position occupied at the moment these events occur.

The Secure Position is coded on 11 bits only, providing actually the most significant bits of the position, the non coded least significant bits being set to '0'.

Vmax [3 : 0]

Maximum velocity

Index	Vmax				Vmax(full step/s)	Group
0	0	0	0	0	99	A
1	0	0	0	1	136	B
2	0	0	1	0	167	
3	0	0	1	1	197	
4	0	1	0	0	213	
5	0	1	0	1	228	
6	0	1	1	0	243	
7	0	1	1	1	273	C
8	1	0	0	0	303	
9	1	0	0	1	334	
A	1	0	1	0	364	
B	1	0	1	1	395	D
C	1	1	0	0	456	
D	1	1	0	1	546	
E	1	1	1	0	729	
F	1	1	1	1	973	

Vmin [3 : 0]

Minimum velocity.

Index	Vmin				Vmax factor
0	0	0	0	0	1
1	0	0	0	1	1/32
2	0	0	1	0	2/32
3	0	0	1	1	3/32
4	0	1	0	0	4/32
5	0	1	0	1	5/32
6	0	1	1	0	6/32
7	0	1	1	1	7/32
8	1	0	0	0	8/32
9	1	0	0	1	9/32
A	1	0	1	0	10/32
B	1	0	1	1	11/32
C	1	1	0	0	12/32
D	1	1	0	1	13/32
E	1	1	1	0	14/32
F	1	1	1	1	15/32

Acc [3 : 0]

Acceleration and deceleration between Vmax and Vmin.

Index	Acc				Acceleration (Full-step/s ²)
0	0	0	0	0	49 (*)
1	0	0	0	1	218 (*)
2	0	0	1	0	1004 .
3	0	0	1	1	3609 .
4	0	1	0	0	6228 .
5	0	1	0	1	8848 .
6	0	1	1	0	11409 .
7	0	1	1	1	13970 .
8	1	0	0	0	16531 .
9	1	0	0	1	19092 (*)
A	1	0	1	0	21886 (*)
B	1	0	1	1	24447 (*)
C	1	1	0	0	27008 (*)
D	1	1	0	1	29570 (*)
E	1	1	1	0	34925 (*)
F	1	1	1	1	40047 (*)

(*) restriction on speed

- SleepEn** IF SleepEn=1 -> AMIS-30623 always go to low-power sleep mode incase LIN timeout.
IF SleepEn=0 -> there is no more automatic transition to low-current sleep mode (i.e. stay in stop mode with applied hold current, unless there are failures).
- FailSafe** IF FailSafe=1 -> in case of LIN lost at POR start a motion to a safe position
IF FailSafe =0 -> no motion in case of LIN lost

15.2.9. RAM Registers

Table 19: RAM Registers

Register	Mnemonic	Length (bit)	Related commands	Comment	Reset state
Actual position	ActPos	16	GetActualPos GetFullStatus GotoSecurePos ResetPosition	16-bit signed	Note 1
Last programmed position	Pos/ TagPos	16/11	GetFullStatus GotoSecurePos ResetPosition SetPosition SetPositionShort	16-bit signed or 11-bit signed for half stepping (see Positioning)	
Acceleration shape	AccShape	1	GetFullStatus ResetToDefault² SetMotorParam	'0' ⇒ normal acceleration from Vmin to Vmax '1' ⇒ motion at Vmin without acceleration	'0'
Coil peak current	Irun	4	GetFullStatus ResetToDefault² SetMotorParam	Operating current See look-up table Irun	From OTP memory
Coil hold current	Ihold	4	GetFullStatus ResetToDefault² SetMotorParam	Standstill current See look-up table Ihold	
Minimum Velocity	Vmin	4	GetFullStatus ResetToDefault² SetMotorParam	See Section 13.3 Minimum Velocity See look-up table Vmin	
Maximum Velocity	Vmax	4	GetFullStatus ResetToDefault² SetMotorParam	See Section 13.2 Maximum Velocity See look-up table Vmax	
Shaft	Shaft	1	GetFullStatus ResetToDefault² SetMotorParam	Direction of movement for positive velocity	
Acceleration/ deceleration	Acc	4	GetFullStatus ResetToDefault² SetMotorParam	See Section 13.4 Acceleration See look-up table Acc	
Secure Position	SecPos	11	GetFullStatus ResetToDefault² SetMotorParam	Target position when LIN connection fails; 11 MSBs of 16-bit position (LSBs fixed to '0')	
Stepping mode	StepMode	2	GetFullStatus SetStallParam	See Section 13.1 Stepping Modes See look-up table StepMode	
Stall detection absolute threshold	AbsThr	4	GetFullStatus SetStallParam		
Stall detection delta threshold	DelThr	4	GetFullStatus SetStallParam		
Sleep Enable	SleepEn		SetOTPParam	Enables entering sleep mode after LIN lost See also 16.8 LIN lost behavior	
Fail Safe	FailSafe		SetOTPParam	Triggers autonomous motion after LIN lost at POR See also 16.8 LIN lost behavior	
Stall detection delay	FS2StallEn	3	GetFullStatus SetStallParam	Delays the stall detection after acceleration	'000'
Stall detection sampling	MinSamples	3	GetFullStatus SetStallParam		'000'
PWM Jitter	PWMJEn	1	GetFullStatus SetStallParam	'1' means jitter is added	'0'
100% duty cycle Stall Disable	DC100SDis	1	GetFullStatus SetStallParam	'1' means stall detection is disabled in case PWM regulator runs at $\delta = 100\%$	'0'
PWM frequency	PWMFreq	1	GetFullStatus SetMotorParam		'0'

Note 1: A `ResetToDefault` command will act as a reset of the RAM content, except for `ActPos` and `TagPos` registers that are not modified. Therefore, the application should not send a `ResetToDefault` during a motion, to avoid any unwanted change of parameter.

15.2.10. Flags Table

Table 20: Flags Table

Flag	Mnemonic	Length (bit)	Related Commands	Comment	Reset State
Charge pump failure	CPFail	1	GetFullStatus	'0' = charge pump OK '1' = charge pump failure reset only after GetFullStatus	'0'
Electrical defect	ElDef	1	GetActualPos GetStatus GetFullStatus	<OVC1> or <OVC2> or <open circuit 1> or <open circuit 2> or <CPFail> resets only after Get (Full) Status	'0'
External switch status	ESW	1	GetActualPos GetStatus GetFullStatus	'0' = open '1' = close	'0'
Electrical flag	HS	1	Internal use	<CPFail> or <UV2> or <ElDef> or <VDDreset>	'0'
Motion status	Motion	3	GetFullStatus	"x00" = Stop "001" = inner motion acceleration "010" = inner motion deceleration "011" = inner motion max. speed "101" = outer motion acceleration "110" = outer motion deceleration "111" = outer motion max. speed	"000"
Over current in coil X	OVC1	1	GetFullStatus	'1' = over current reset only after GetFullStatus	'0'
Over current in coil Y	OVC2	1	GetFullStatus	'1' = over current reset only after GetFullStatus	'0'
Secure position enabled	SecEn	1	Internal use	'0' if SecPos = "100 0000 0000" '1' otherwise	n.a.
Circuit going to Sleep mode	Sleep	1	Internal use	'1' = Sleep mode reset by LIN command	'0'
Step loss	StepLoss	1	GetActualPos GetStatus GetFullStatus	'1' = step loss due to under voltage, over current or open circuit	'1'
Delta High Stall	DelStallHi	1	GetFullStatus	'1' = $V_{bemf} > \bar{U}_{bemf} + \Delta_{thr}$	'0'
Delta Low Stall	DelStallLo	1	GetFullStatus	'1' = $V_{bemf} > \bar{U}_{bemf} - \Delta_{thr}$	'0'
Absolute Stall	AbsStall	1	GetFullStatus	'1' = $V_{bemf} > Abs_{thr}$	'0'
Stall	Stall	1	GetFullStatus GetStatus		'0'
Motor stop	Stop	1	Internal use		'0'
Temperature info	Tinfo	2	GetActualPos GetStatus GetFullStatus	"00" = normal temperature range "01" = low temperature warning "10" = high temperature warning "11" = motor shutdown	"00"
Thermal shutdown	TSD	1	GetActualPos GetStatus GetFullStatus	'1' = shutdown. (> 155°C typ.) reset only after Get (Full) Status and if <Tinfo> = "00"	'0'
Thermal warning	TW	1	GetActualPos GetStatus GetFullStatus	'1' = over temp. (> 145°C) reset only after Get (Full) Status and if <Tinfo> = "00"	'0'
Battery stop voltage	UV2	1	GetActualPos GetStatus GetFullStatus	'0' = $V_{bb} > UV2$ '1' = $V_{bb} \leq UV2$ reset only after Get (Full) Status	'0'
Digital supply reset	VddReset	1	GetActualPos GetStatus GetFullStatus	Set at '1' after power-up of the circuit. If this was due to a supply micro-cut, it warns that the RAM contents may have been lost; can be reset to '0' with a GetStatus or a GetFullStatus command.	'1'

15.2.10.1. Priority Encoder

The table below describes the state management performed by the main control block.

Table 21: Priority Encoder

State →	Stopped	GotoPos	DualPosition	SoftStop	HardStop	ShutDown	Sleep
Command ↓	motor stopped, lhold in coils	motor motion ongoing	no influence on RAM and TagPos	motor decelerating	motor forced to stop	motor stopped, H-bridges in Hi-Z	no power (note 1)
GetActualPos	LIN in-frame response	LIN in-frame response	LIN in-frame response	LIN in-frame response	LIN in-frame response	LIN in-frame response	
GetOTPparam	OTP refresh; LIN in-frame response	OTP refresh; LIN in-frame response	OTP refresh; LIN in-frame response	OTP refresh; LIN in-frame response	OTP refresh; LIN in-frame response	OTP refresh; LIN in-frame response	
GetFullStatus or GetStatus [attempt to clear <TSD> and <HS> flags]	LIN in-frame response	LIN in-frame response	LIN in-frame response	LIN in-frame response	LIN in-frame response	LIN in-frame response; if (<TSD> or <HS>) = '0' then → Stopped	
ResetToDefault [ActPos and TagPos are not altered]	OTP refresh; OTP to RAM; AccShape reset	OTP refresh; OTP to RAM; AccShape reset	OTP refresh; OTP to RAM; AccShape reset (note 3)	OTP refresh; OTP to RAM; AccShape reset	OTP refresh; OTP to RAM; AccShape reset	OTP refresh; OTP to RAM; AccShape reset	
SetMotorParam [Master takes care about proper update]	RAM update	RAM update	RAM update	RAM update	RAM update	RAM update	
ResetPosition	TagPos and ActPos reset					TagPos and ActPos reset	
SetPosition	TagPos updated; → GotoPos	TagPos updated	TagPos updated				
SetPositionShort [half-step mode only]	TagPos updated; → GotoPos	TagPos updated	TagPos updated				
GotoSecPosition	If <SecEn> = '1' then TagPos = SecPos; → GotoPos	If <SecEn> = '1' then TagPos = SecPos	If <SecEn> = '1' then TagPos = SecPos				
DualPosition	→ DualPosition						
HardStop		→ HardStop ; <StepLoss> = '1'	→ HardStop ; <StepLoss> = '1'	→ HardStop ; <StepLoss> = '1'			
SoftStop		→ SoftStop					
Sleep or LIN timeout [⇒ <Sleep> = '1', reset by any LIN command received later]	See note 9	If <SecEn> = '1' then TagPos = SecPos else → SoftStop	If <SecEn> = '1' then TagPos = SecPos; will be evaluated after DualPosition	No action; <Sleep> flag will be evaluated when motor stops	No action; <Sleep> flag will be evaluated when motor stops	→ Sleep	
HardStop [⇔ (<CPFail> or <UV2> or <ElDef>) = '1' ⇒ <HS> = '1']	→ Shutdown	→ HardStop	→ HardStop	→ HardStop			
Thermal shutdown [<TSD> = '1']	→ Shutdown	→ SoftStop	→ SoftStop				
Motion finished	n.a.	→ Stopped	→ Stopped	→ Stopped ; TagPos = ActPos	→ Stopped ; TagPos = ActPos	n.a.	n.a.

With the following color code:

	Command ignored
	Transition to another state
	Master is responsible for proper update (see note 7)

- Notes:**
- 1) Leaving sleep state is equivalent to power-on-reset.
 - 2) After power-on-reset, the shutdown state is entered. The shutdown state can only be left after [GetFullStatus](#) command (so that the master could read the <VddReset> flag).
 - 3) A DualPosition sequence runs with a separate set of RAM registers. The parameters that are not specified in a DualPosition command are loaded with the values stored in RAM at the moment the DualPosition sequence starts. AccShape is forced to '1' during second motion even if a ResetToDefault command is issued during a DualPosition sequence, in which case AccShape at '0' will be taken into account after the DualPosition sequence. A [GetFullStatus](#) command will return the default parameters for Vmax and Vmin stored in RAM.
 - 4) The <Sleep> flag is set to '1' when a LIN timeout or a Sleep command occurs. It is reset by the next LIN command (<Sleep> is cancelled if not activated yet).
 - 5) Shutdown state can be left only when <TSD> and <HS> flags are reset.
 - 6) Flags can be reset only after the master could read them via a [GetStatus](#) or [GetFullStatus](#) command, and provided the physical conditions allow for it (normal temperature, correct battery voltage and no electrical or charge pump defect).
 - 7) A SetMotorParam command sent while a motion is ongoing (state GotoPos) should not attempt to modify Acc and Vmin values. This can be done during a DualPosition sequence since this motion uses its own parameters, the new parameters will be taken into account at the next SetPosition or SetPositionShort command.
 - 8) Some transitions like GotoPos → Sleep are actually done via several states: GotoPos → SoftStop → Stopped → Sleep (see diagram below).
 - 9) Two transitions are possible from state Stopped when <Sleep> = '1':
 - 1) Transition to state Sleep if (<SecEn> = '0') or ((<SecEn> = '1') and (ActPos = SecPos)) or <Stop> = '1'
 - 2) Otherwise transition to state GotoPos, with TagPos = SecPos
 - 10) <SecEn> = '1' when register SecPos is loaded with a value different from the most negative value (i.e. different from 0x400 = "100 0000 0000")
 - 11) <Stop> flag allows to distinguish whether state stopped was entered after HardStop/SoftStop or not. <Stop> is set to '1' when leaving state HardStop or SoftStop and is reset during first clock edge occurring in state Stopped.
 - 12) Command for dynamic assignment of Ids is decoded in all states except sleep and has not effect on the current state
 - 13) While in state stopped, if ActPos → TagPos there is a transition to state GotoPos. This transition has the lowest priority, meaning that <Sleep>, <Stop>, <TSD>, etc. are first evaluated for possible transitions.
 - 14) If <StepLoss> is active, then SetPosition, SetPositionShort and GotoSecurePosition commands are ignored (they will not modify TagPos register whatever the state), and motion to secure position is forbidden after a Sleep command or a LIN timeout (the circuit will go into Sleep state immediately, without positioning to secure position). Other command like DualPosition or ResetPosition will be executed if allowed by current state. <StepLoss> can only be cleared by a [GetStatus](#) or [GetFullStatus](#) command.

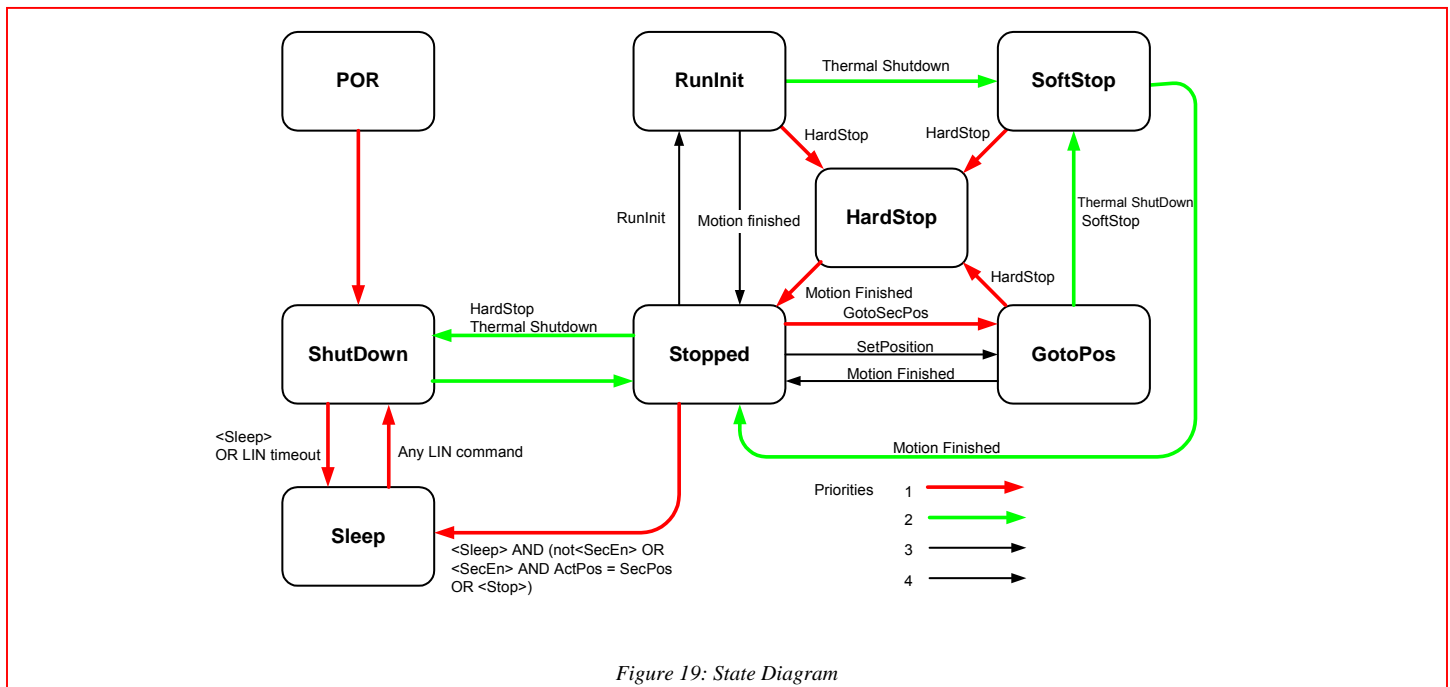

Figure 19: State Diagram

Remark: IF "SleepEn"=0, then the red arrow from stopped state to sleep state does not exist.

15.3 Motordriver

15.3.1. Current Waveforms in the Coils

The figure below illustrates the current fed to the motor coils by the motordriver in half-step mode.

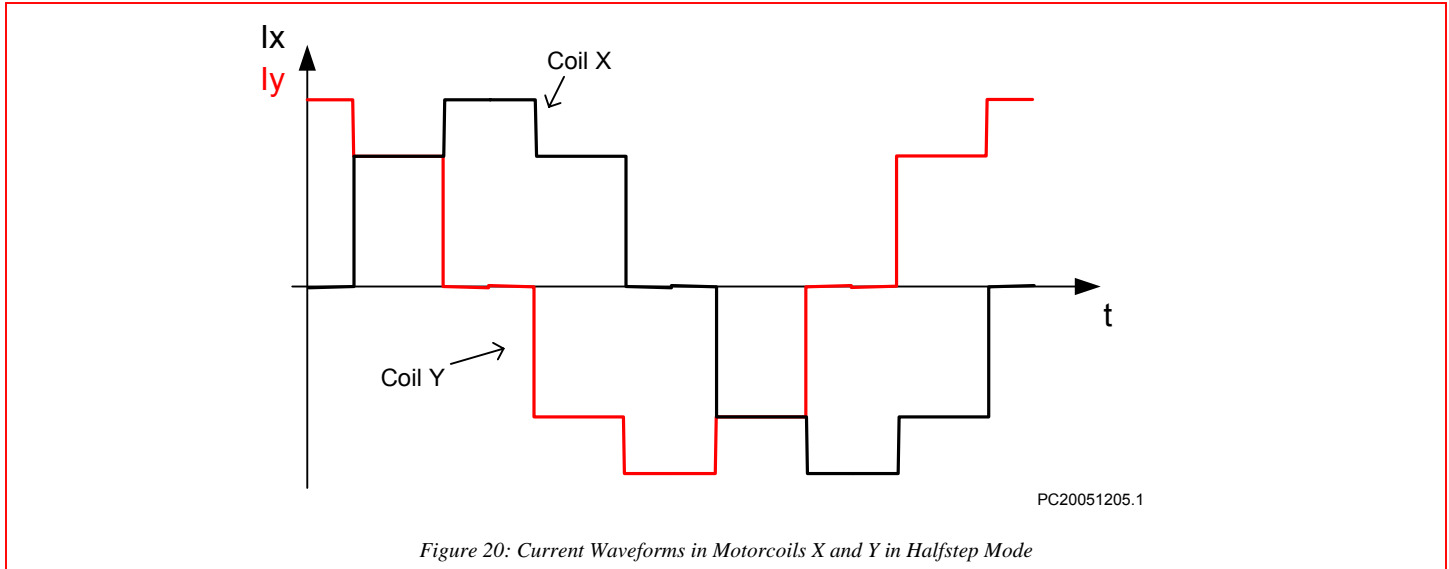

Whereas the figure below shows the current fed to one coil in 1/16th micro stepping (1 electrical period).

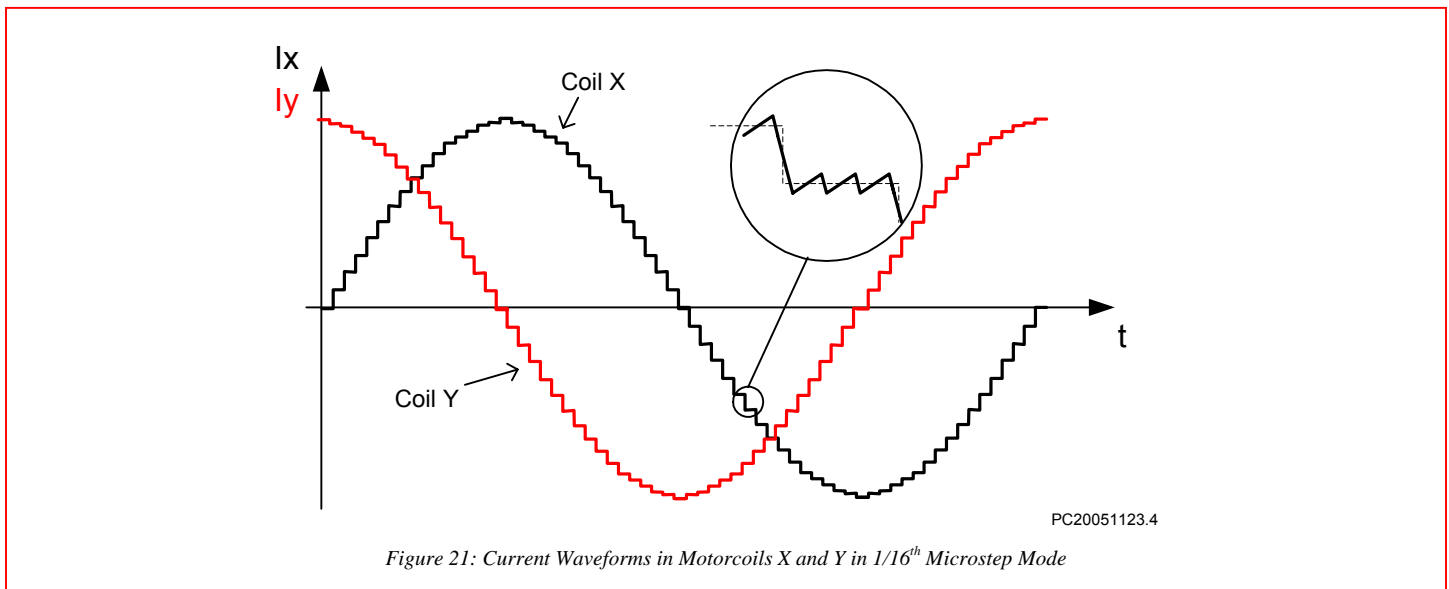

15.3.2. PWM Regulation

In order to force a given current (determined by I_{run} or I_{hold} and the current position of the rotor) through the motor coil while ensuring high energy transfer efficiency, a regulation based on PWM principle is used. The regulation loop performs a comparison of the sensed output current to an internal reference, and features a digital regulation generating the PWM signal that drives the output switches. The zoom over one micro-step in the figure above shows how the PWM circuit performs this regulation. To reduce the current ripple, a higher PWM frequency should be selectable. The RAM register PWMfreq is used for this (Bit 0 in Data 8 of [SetMotorParam](#)).

Table 22: PWM Frequency Selection

PWMfreq	Applied PWM Frequency
0	22,8 kHz
1	45,6 kHz

15.3.3. PWM Jitter

To lower the power spectrum for the fundamental and higher harmonics of the PWM frequency, jitter can be added to the PWM clock. The RAM register PWMJEn is used for this. (Bit 0 in Data 8 of [SetStallParam](#)). Readout with [GetFullStatus](#) (Bit 0 Data 8 IFR 2).

Table 23: PWM Jitter Selection

PWMJEn	Status
0	Single PWM frequency
1	Added jitter to PWM frequency

15.3.4. Motor Starting Phase

At motion start, the currents in the coils are directly switched from I_{hold} to I_{run} with a new sine/cosine ratio corresponding to the first half (or micro) step of the motion.

15.3.5. Motor Stopping Phase

At the end of the deceleration phase, the currents are maintained in the coils at their actual DC level (hence keeping the sine/cosine ratio between coils) during the stabilization time t_{stab} (see [AC Table](#)). The currents are then set to the hold values, respectively $I_{hold} \times \sin(TagPos)$ and $I_{hold} \times \cos(TagPos)$ as illustrated below. A new positioning order can then be executed.

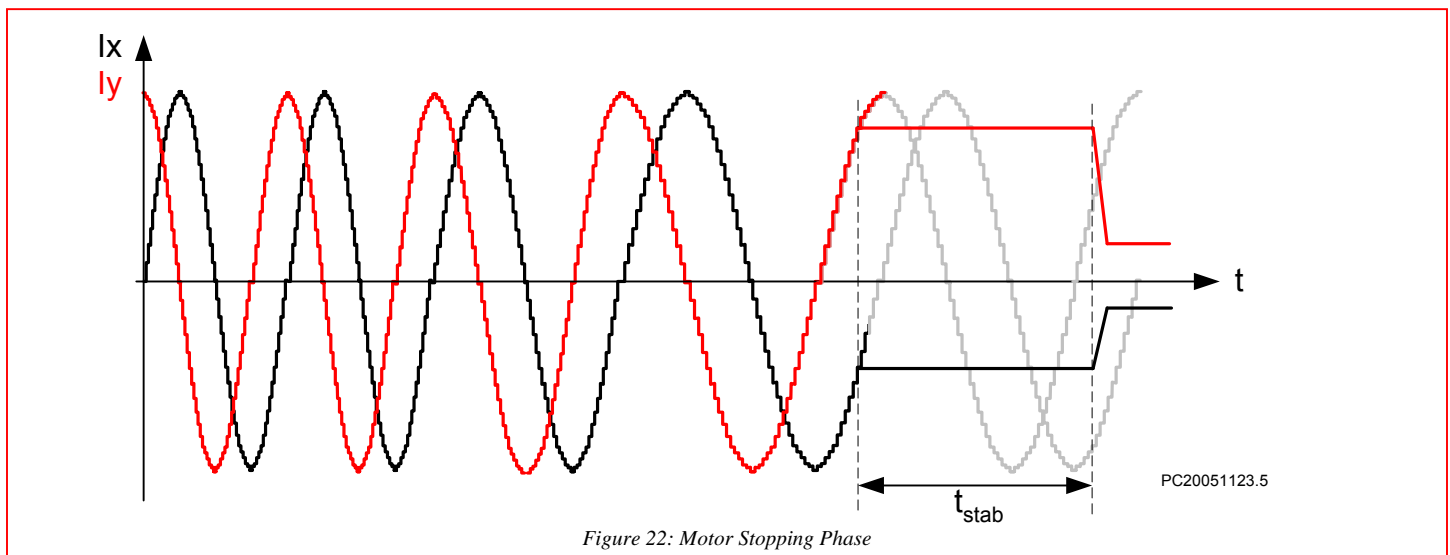

15.3.6. Charge Pump Monitoring

If the charge pump voltage is not sufficient for driving the high side transistors (due to a failure), an internal `HardStop` command is issued. This is acknowledged to the master by raising flag `<CPFail>` (available with command [GetFullStatus](#)).

In case this failure occurs while a motion is ongoing, the flag `<StepLoss>` is also raised.

15.3.7. Electrical Defect on Coils, Detection and Confirmation

The principle relies on the detection of a voltage drop on at least one transistor of the H-bridge. Then the decision is taken to open the transistors of the defective bridge.

This allow to detect the following short circuits:

- External coil short circuit
- Short between one terminal of the coil and Vbat or Gnd
- One cannot detect internal short in the motor

Open circuits are detected by 100% PWM duty cycle value during a long time

Table 24: Electrical Defect Detection

Pins	Fault mode
Yi or Xi	Short circuit to GND
Yi or Xi	Short circuit to Vbat
Yi or Xi	Open
Y1 and Y2	Short circuited
X1 and X2	Short circuited
Xi and Yi	Short circuited

15.3.8. Motor Shutdown Mode

A motor shutdown occurs when:

- The chip temperature rises above the thermal shutdown threshold T_{sd} (see [Thermal Shutdown Mode](#))
- The battery voltage goes below UV2 (see [Battery voltage management](#))
- Flag $\langle ElDef \rangle = '1'$, meaning an electrical problem is detected on one or both coils, e.g. a short circuit.
- Flag $\langle CPFail \rangle = '1'$, meaning there is a charge pump failure

A motor shutdown leads to the following:

- H-bridges in high impedance mode
- The $TagPos$ register is loaded with the $ActPos$ (to avoid any motion after leaving the motor shutdown mode)

The LIN interface remains active, being able to receive orders or send status.

The conditions to get out of a motor shutdown mode are:

- Reception of a [GetStatus](#) or [GetFullStatus](#) command AND
- The four above causes are no more detected

Which leads to H-bridges in Ihold mode. Hence, the circuit is ready to execute any positioning command.

This can be illustrated in the following sequence given as an application tip. The master can check whether there is a problem or not and decide which application strategy to adopt.

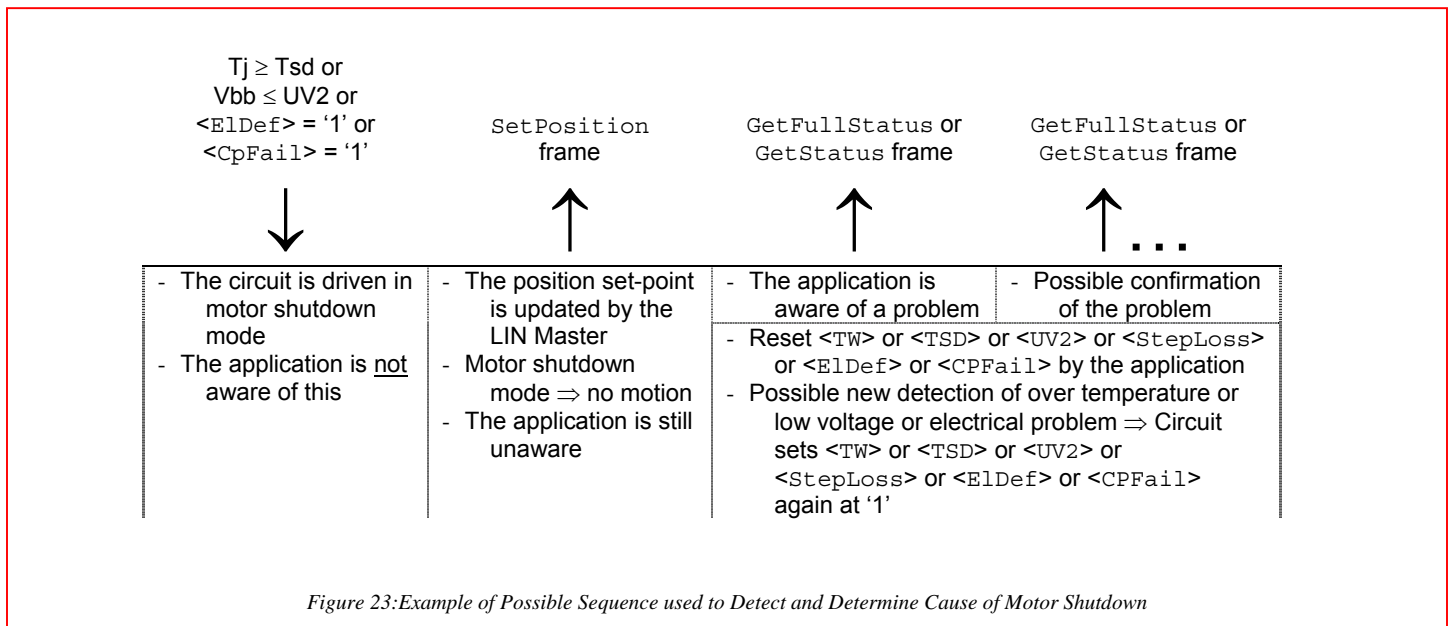

Important: While in shutdown mode, since there is no hold current in the coils, the mechanical load can cause a step loss, which indeed cannot be flagged by the AMIS-30623.

Warning: The application should limit the number of consecutive [GetStatus](#) or [GetFullStatus](#) commands to try to get the AMIS-30623 out of shutdown mode when this proves to be unsuccessful, e.g. there is a permanent defect. The reliability of the circuit could be altered since `Get (Full) Status` attempts to disable the protection of the H-bridges.

Notes

- (0) The [Priority Encoder](#) is describing the management of states and commands. The note below is to be considered illustrative.
- (1) If the LIN communication is lost while in shutdown mode, the circuit enters the sleep mode immediately

15.4 Motion Detection

Motion detection is based on the back emf generated internally in the running motor. When the motor is blocked, e.g. when it hits the end-position, the velocity and as a result also the generated back emf, is disturbed. The AMIS-30623 senses the back emf, calculates a moving average and compares the value with two independent threshold levels: Absolute threshold ([AbsThr\[3:0\]](#)) and Delta threshold ([DelThr\[3:0\]](#)). Instructions for correct use of these two levels in combination with three additional parameters (MinSamples, FS2StallEn and DC100SDis) are outside the scope of this datasheet. Detailed information is available in a dedicated white paper "Robust Motion Control with AMIS-3062x Stepper Motor Drivers", available on <http://www.amis.com/>.

If the motor is accelerated by a pulling or propelling force and the resulting back emf increases above the Delta threshold (+ ΔTHR), then `<DelStallHi>` is set. When the motor is slowing down and the resulting back emf decreases below the Delta threshold (- ΔTHR), then `<DelStallLo>` is set. When the motor is blocked and the velocity is zero after the acceleration phase, the back emf is low or zero. When this value is below the Absolute threshold, `<AbsStall>` is set. The `<Stall>` flag is the OR function of `<DelStallLo>` OR `<DelStallHi>` OR `<AbsStall>`.

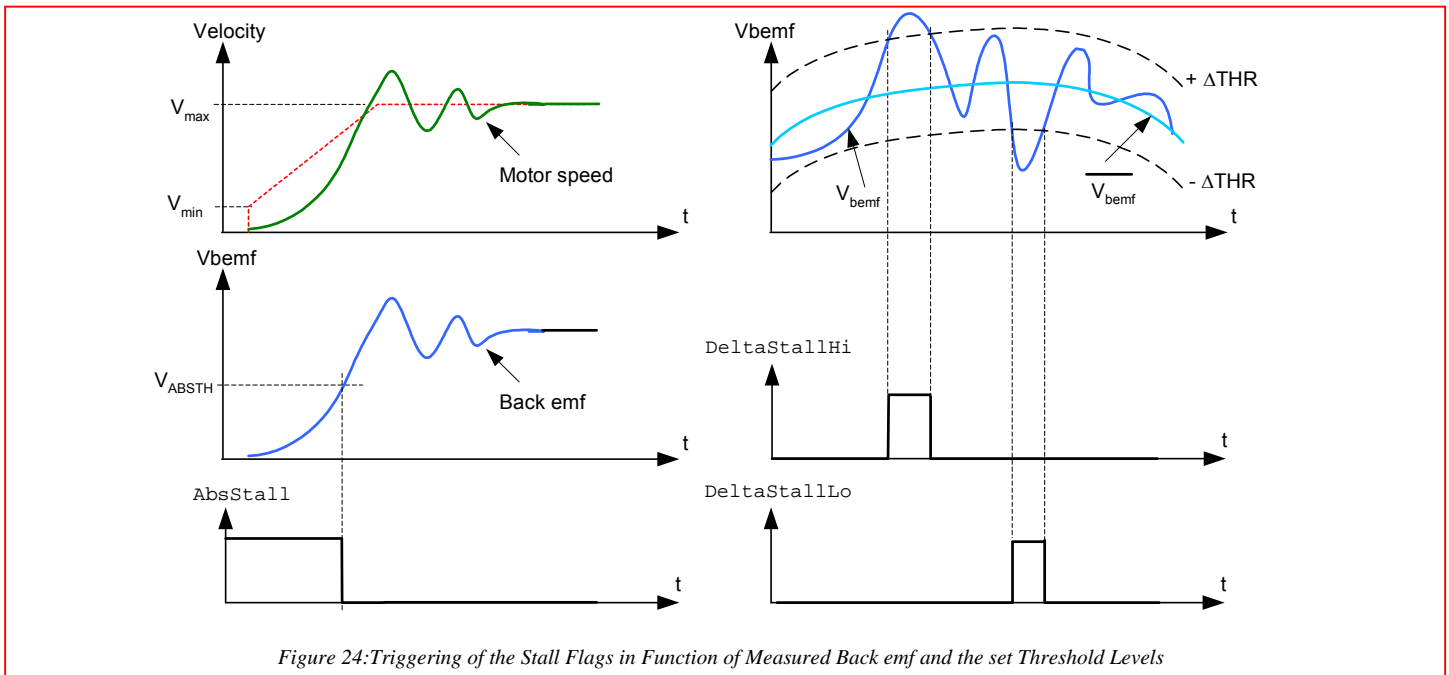

Figure 24: Triggering of the Stall Flags in Function of Measured Back emf and the set Threshold Levels

Table 25: Truth Table

Condition	<code><DelStallLo></code>	<code><DelStallHi></code>	<code><AbsStall></code>	<code><Stall></code>
$V_{bemf} < \text{Average} - \text{DelThr}$	1	0	0	1
$V_{bemf} > \text{Average} + \text{DelThr}$	0	1	0	1
$V_{bemf} < \text{AbsThr}$	0	0	1	1

The motion will only be detected when the motor is running at the maximum velocity, not during acceleration or deceleration.

If the motor is positioning when Stall is detected, an (internal) hardstop of the motor is generated and the `<StepLoss>` and `<Stall>` flags are set. These flags can only be reset by sending a [GetFullStatus](#) command.

If Stall appears during DualPosition then the first phase is cancelled (via internal Hardstop) and after timeout (26.6 ms) the second phase at v_{min} starts.

When the `<Stall>` flag is set the position controller will generate an internal HardStop. As a consequence also the Steploss flag will be set. The position in the internal counter will be copied to the ActPos register. All flags can be read out with the [GetStatus](#) or [GetFullStatus](#) command.

Important remark:

Using [GetFullStatus](#) will read **AND** clear the following flags: `<Steploss>`, `<Stall>`, `<AbsStall>`, `<DelStallLo>`, and `<DelStallHi>`. New positioning is possible and the ActPos register will be further updated.

Using [GetStatus](#) will read **AND** clear **ONLY** the `<Steploss>` flag. The `<Stall>`, `<AbsStall>`, `<DelStallLo>`, and `<DelStallHi>` flags are NOT cleared. New positioning is possible and the ActPos register will be further updated.

Motion detection is disabled when the RAM registers AbsThr[3:0] and DelThr[3:0] are empty or zero. Both levels can be programmed using the LIN command SetStallParam in the registers AbsThr[3:0] and DelThr[3:0]. Also in the OTP register AbsThr[3:0] and DelThr[3:0] can be set using the LIN command SetOTPParam. These values are copied in the RAM registers during power on reset. Value Table:

Table 26: Absolute Threshold Settings

AbsThr index	AbsThr level (V)
0	Disable
1	0.5
2	1.0
3	1.5
4	2.0
5	2.5
6	3.0
7	3.5
8	4.0
9	4.5
A	5.0
B	5.5
C	6.0
D	6.5
E	7.0
F	7.5

Table 27: Delta Threshold Settings

DelThr index	DelThr level (V)
0	Disable
1	0.25
2	0.50
3	0.75
4	1.00
5	1.25
6	1.50
7	1.75
8	2.00
9	2.25
A	2.50
B	2.75
C	3.00
D	3.25
E	3.50
F	3.75

MinSamples

MinSamples[2:0] is a Bemf sampling delay time expressed in number of PWM cycles, for more information please refer to the white paper “Robust Motion Control with AMIS-3062x Stepper Motor Drivers”,

Table 28: Back EMF Sample Delay Time

Index	MinSamples[2:0]	t _{DELAY} (µs)	
		PWMfreq = 0	PWMfreq = 1
0	000	87	43
1	001	130	65
2	010	174	87
3	011	217	109
4	100	261	130
5	101	304	152
6	110	348	174
7	111	391	196

FS2StallEn

If AbsThr or DelThr <>0 (i.e. motion detection is enabled), then stall detection will be activated AFTER the acceleration ramp + an additional number of full-steps, according to the following table :

Table 29: Activation Delay of Motion Detection

Index	FS2StallEn[2:0]	Delay (Full Steps)
0	000	0
1	001	1
2	010	2
3	011	3
4	100	4
5	101	5
6	110	6
7	111	7

For more information please refer to the white paper “Robust Motion Control with AMIS-3062x Stepper Motor Drivers”,

DC100SDis

When a motor with large bemf is operated at high speed and low supply voltage, then the PWM duty cycle can be as high as 100%. This indicates that the supply is too low to generate the required torque and might also result in erroneously triggering the stall detection. The bit “DC100SDis” disables stall detection when duty cycle is 100%. For more information please refer to the white paper “Robust Motion Control with AMIS-3062x Stepper Motor Drivers”,

Motion Qualification Mode

This mode is useful to debug motion parameters and to verify the stability of stepper motor systems. The motion qualification mode is entered by means of the LIN command [TestBemf](#). The SWI pin will be converted into an analogue output on which the Bemf integrator output can be measured. Once activated, it can only be stopped after a POR. During the Back emf observation, reading of the SWI state is internally forbidden.

More information is available in the white paper "Robust Motion Control with AMIS-3062x Stepper Motor Drivers".

16.0 Lin Controller

16.1 General Description

The LIN (local interconnect network) is a serial communications protocol that efficiently supports the control of mechatronic nodes in distributed automotive applications. The interface implemented in the AMIS-30623 is compliant with the LIN rev. 1.3 specifications. It features a slave node, thus allowing for:

- single-master / multiple-slave communication
- self synchronization without quartz or ceramics resonator in the slave nodes
- guaranteed latency times for signal transmission
- single-wire communication
- transmission speed of 19.2 kbit/s
- selectable length of Message Frame: 2, 4, and 8 bytes
- configuration flexibility
- data checksum security and error detection;
- detection of defective nodes in the network.

It includes the analog physical layer and the digital protocol handler.

The analog circuitry implements a low side driver with a pull-up resistor as a transmitter, and a resistive divider with a comparator as a receiver. The specification of the line driver/receiver follows the ISO 9141 standard with some enhancements regarding the EMI behavior.

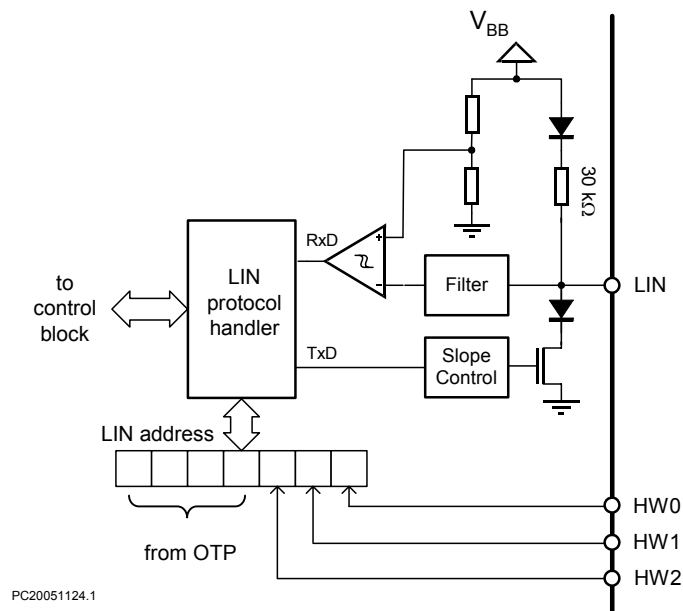

Figure 25:LIN Interface

16.2 Slave Operational Range for Proper Self Synchronization

The LIN interface will synchronize properly in the following conditions:

- $V_{bb} \geq 8\text{ V}$
- Ground shift between master node and slave node $< \pm 1\text{V}$

It is highly recommended to use the same type of reverse battery voltage protection diode for the Master and the Slave nodes.

16.3 Functional Description

16.3.1. Analog Part

The transmitter is a low-side driver with a pull-up resistor and slope control. [Figure 5](#) shows the characteristics of the transmitted signal, including the delay between internal TxD – and LIN signal. See [AC Parameters](#) for timing values.

The receiver mainly consists of a comparator with a threshold equal to $V_{bb}/2$. [Figure 5](#) also shows the delay between the received signal and the internal RXD signal. See also [AC Parameters](#) for timing values.

16.3.2. Protocol Handler

This block implements:

- bit synchronization
- bit timing
- the MAC layer
- the LLC layer
- the supervisor

16.3.3. Electro Magnetic Compatibility

EMC behavior fulfills requirements defined by LIN specification, rev. 1.3.

16.4 Error Status Register

The LIN interface implements a register containing an error status of the LIN communication. This register is as follows:

Table 30: LIN Error Register

Bit 7	Bit 6	Bit 5	Bit 4	Bit 3	Bit 2	Bit 1	Bit 0
Not used	Not used	Not used	Not used	Time out error	Data error Flag	Header error Flag	Bit error Flag

With:

Time out error:

Data error flag = Checksum error + StopBit error + Length error

Header error flag = Parity + SynchField error

Bit error flag :

A [GetFullStatus](#) frame will reset the error status register.

16.5 Physical Address of the Circuit

The circuit must be provided with a physical address in order to discriminate this circuit from other ones on the LIN bus. This address is coded on 7 bits, yielding the theoretical possibility of 128 different circuits on the same bus. It is a combination of 4 OTP memory bits and of the 3 hardwired address bits (pins HW[2:0]). However the maximum number of nodes in a LIN network is also limited by the physical properties of the bus line. It is recommended to limit the number of nodes in a LIN network to not exceed 16. Otherwise the reduced network impedance may prohibit a fault free communication under worst case conditions. Every additional node lowers the network impedance by approximately 3%.

AD6	AD5	AD4	AD3	AD2	AD1	AD0	Physical address
↑	↑	↑	PA3	PA2	PA1	PA0	OTP memory
HW0 HW1 HW2							Hardwired bits

Note:

Pins HW0 and HW1 are 5V digital inputs, whereas pin HW2 is compliant with a 12V level, e.g. it can be connected to Vbat or Gnd via a terminal of the PCB. To provide cleaning current for this terminal, the system used for pin SW1 is also implemented for pin HW2 (see [Hardwired Address HW2](#)).

16.6 LIN Frames

The LIN frames can be divided in writing and reading frames. A frame is composed of an 8-bit Identifier followed by 2, 4 or 8 data-bytes. Writing frames will be used to:

- Program the OTP Memory;
- Configure the component with the stepper-motor parameters (current, speed, stepping-mode, etc.);
- Provide set-point position for the stepper-motor.

Whereas reading frames will be used to:

- Get the actual position of the stepper-motor;
- Get status information such as error flags;
- Verify the right programming and configuration of the component.

16.6.1. Writing Frames

A writing frame is sent by the LIN master to send commands and/or information to the slave nodes. According to the LIN specification, identifiers are to be used to determine a specific action. If a physical addressing is needed, then some bits of the data field can be dedicated to this, as illustrated in the example below.

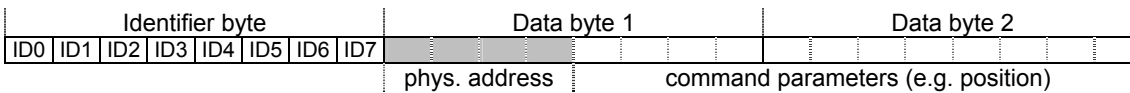

Another possibility is to determine the specific action within the data field in order to use less identifiers. One can for example use the reserved identifier 0x3C and take advantage of the 8 byte data field to provide a physical address, a command and the needed parameters for the action, as illustrated in the example below.

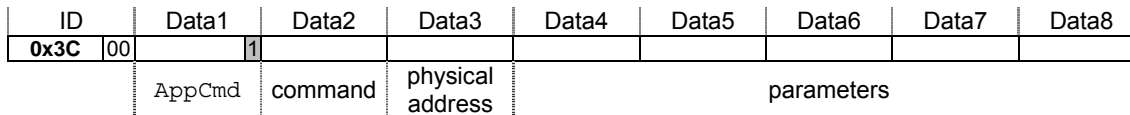

Note:
Bit 7 of byte Data1 must be at '1' since the LIN specification requires that contents from 0x00 to 0x7F must be reserved for broadcast messages (0x00 being for the "Sleep" message). See also LIN command [Sleep](#)

The writing frames used with the AMIS-30623 are the following:

- **Type #1:** General purpose 2 or 4 data bytes writing frame with a dynamically assigned identifier. This type is dedicated to short writing actions when the bus load can be an issue. They are used to provide direct command to one (Broad = '1') or all the slave nodes (Broad = '0'). If Broad = '1', the physical address of the slave node is provided by the 7 remaining bits of DATA2. DATA1 will contain the command code (see [Dynamic assignment of Identifiers](#)), while, if present, DATA3 to DATA4 will contain the command parameters, as shown below.



- **Type #2:** 2, 4 or 8 data bytes writing frame with an identifier dynamically assigned to an application command, regardless of the physical address of the circuit.
- **Type #3:** 2 data bytes writing frame with an identifier dynamically assigned to a particular slave node together with an application command. This type of frame requires that there are as many dynamically assigned identifiers as there are AMIS-30623 circuits using this command connected to the LIN bus.
- **Type #4:** 8 data bytes writing frame with 0x3C identifier.

16.6.2. Reading Frames

A reading frame uses an in-frame response mechanism. That is: the master initiates the frame (synchronization field + identifier field), and one slave sends back the data field together with the check field. Hence, two types of identifiers can be used for a reading frame:

- **Direct ID**, which points at a particular slave node, indicating at the same time which kind of information is awaited from this slave node, thus triggering a specific command. This ID provides the fastest access to a read command but is forbidden for any other action.
- **Indirect ID**, which only specifies a reading command, the physical address of the slave node that must answer having been passed in a previous writing frame, called a preparing frame. Indirect ID gives more flexibility than a direct one, but provides a slower access to a read command.

Notes

- (1) a reading frame with indirect ID must always be consecutive to a preparing frame. It will otherwise not be taken into account.
- (2) a reading frame will always return the physical address of the answering slave node in order to ensure robustness in the communication.

The reading frames used with the AMIS-30623 are the following:

- **Type #5:** 2, 4 or 8 Data bytes reading frame with a direct identifier dynamically assigned to a particular slave node together with an application command. A preparing frame is not needed.
- **Type #6:** 8 Data bytes reading frame with 0x3D identifier. This is intrinsically an indirect type, needing therefore a preparation frame. It has the advantage to use a reserved identifier.

16.6.3. Preparing Frames

A preparing frame is a writing frame that warns a particular slave node that it will have to answer in the next frame (hence a reading frame). A preparing frame is needed when a reading frame does not use a dynamically assigned direct ID. Preparing and reading frames must be consecutive. A preparing frame will contain the physical address of the LIN slave node that must answer in the reading frame, and will also contain a command indicating which kind of information is awaited from the slave.

The preparing frames used with the AMIS-30623 can be of type #7 or type #8 described below.

- **Type #7:** two data bytes writing frame with dynamically assigned identifier.

Preparing Frame									
Byte	Content	Structure							
		Bit 7	Bit 6	Bit 5	Bit 4	Bit 3	Bit 2	Bit 1	Bit 0
0	Identifier	*	*	0	ID4	ID3	ID2	ID1	ID0
1	Data 1	1	CMD [6:0]						
2	Data 2	1	AD [6:0]						

Where:

- (*) According to parity computation

- **Type #8:** eight data bytes writing frame with 0x3C identifier.

SetDualPositioning Writing Frame									
Byte	Content	Structure							
		Bit 7	Bit 6	Bit 5	Bit 4	Bit 3	Bit 2	Bit 1	Bit 0
0	Identifier	0	0	1	1	1	1	0	0
1	Data 1	AppCMD = 0x80							
2	Data 2	1	CMD [6:0]						
3	Data 3	1	AD [6:0]						
4	Data 4	Data4 [7:0]							
5	Data 5	Data5 [7:0]							
6	Data 6	Data6 [7:0]							
7	Data 7	Data7 [7:0]							
8	Data 8	Data8 [7:0]							

Where:

- AppCMD: If '0x80' this indicates that Data 2 contains an application command
 CMD[6:0]: Application Command "byte"
 AD[6:0]: Slave node physical address
 Data[n:0]: Data transmitted

16.6.4. Dynamic Assignment of Identifiers

The identifier field in the LIN datagram denotes the content of the message. Six identifier bits and two parity bits are used to represent the content. The identifiers 0x3C and 0x3F are reserved for command frames and extended frames. Slave nodes need to be very flexible to adapt itself to a given LIN network in order to avoid conflicts with slave nodes from different manufacturers. Dynamic assignment of the identifiers will fulfill this requirement by writing identifiers into the circuits RAM. ROM pointers are linking commands and dynamic identifiers together. A writing frame with identifier 0x3C issued by the LIN master will write dynamic identifiers into the RAM. One writing frame is able to assign 4 identifiers, therefore 3 frames are needed to assign all identifiers. Each ROM pointer ROMp_x [3:0] place the corresponding dynamic identifier Dyn_ID_x [5:0] at the correct place in the RAM (see Table 1: LIN – Dynamic Identifiers Writing Frame).

When setting <BROAD> to zero broadcasting is active and each slave on the LIN bus will store the same dynamic identifiers, otherwise only the slave with the corresponding slave address is programmed.

Dynamic Identifiers Writing Frame									
Byte	Content	Structure							
		Bit 7	Bit 6	Bit 5	Bit 4	Bit 3	Bit 2	Bit 1	Bit 0
0	Identifier	0x3C							
1	AppCmnd	0x80							
2	CMD	1	0x11						
3	Address	Broad	AD6	AD5	AD4	AD3	AD2	AD1	AD0
4	Data	DynID_1[3:0]				ROMp_1[3:0]			
5	Data	DynID_2[1:0]		ROMp_2[3:0]			DynID_1[5:4]		
6	Data	ROMp_3[3:0]				DynID_2[5:2]			
7	Data	ROMp_4[2:0]		DynID_3[5:0]					
8	Data	DynID_4[5:0]						ROMp_4[3:2]	

Where:

CMD[6:0]: 0x11, corresponding to dynamic assignment of four LIN identifiers

Broad: If broad = '0' all the circuits connected to the LIN bus will share the same dynamically assigned identifiers.

DynID_x[5:0]: Dynamically assigned LIN identifier to the application command which ROM pointer is ROMp_x[3:0]

One frame allows only to assign four identifiers. Therefore, additional frames could be needed in order to assign more identifiers (maximum three for the AMIS-30623).

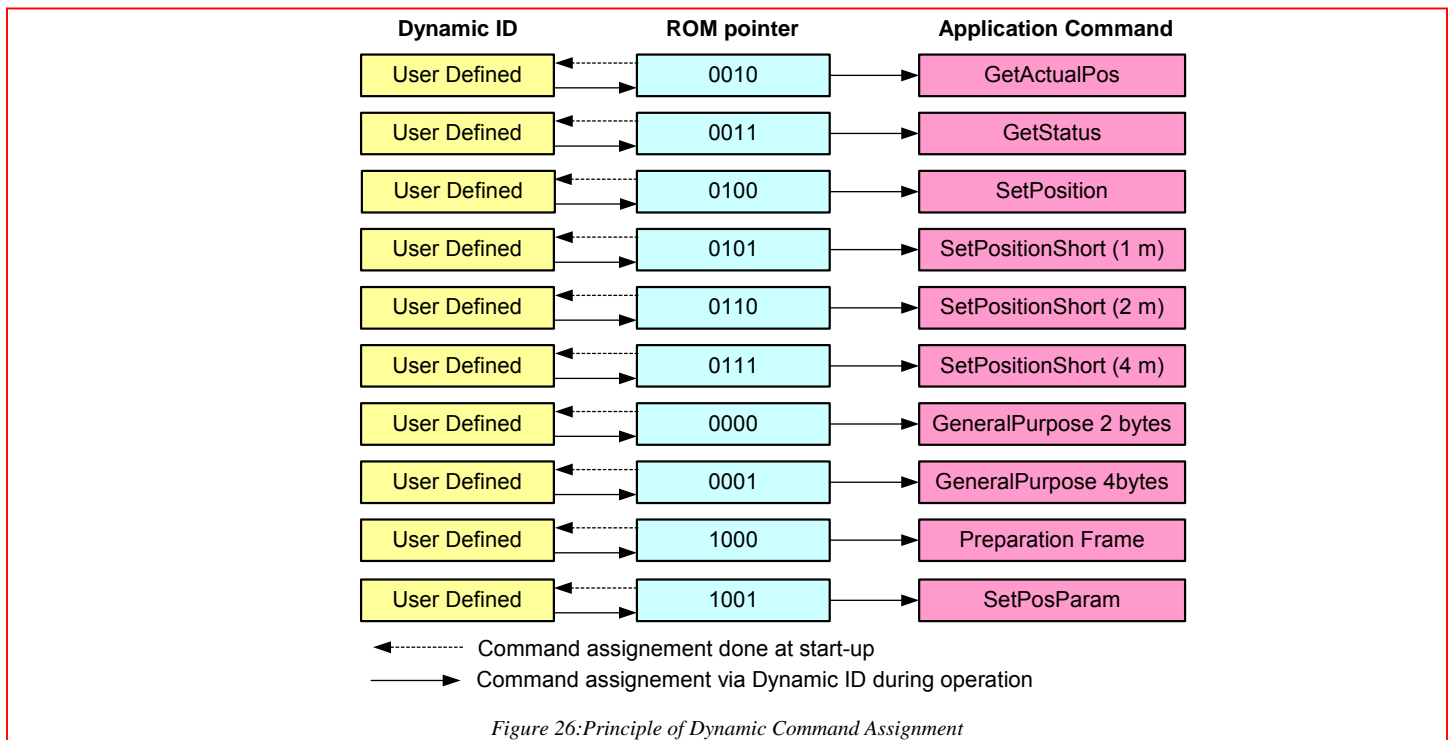

16.7 Commands Table

Table 31: LIN Commands with Corresponding ROM Pointer

Command mnemonic	Command byte (CMD)		Dynamic ID (example)	ROM pointer
GetActualPos	000000	0x00	100xxx	0010
GetFullStatus	000001	0x01	n.a.	
GetOTParam	000010	0x02	n.a.	
GetStatus	000011	0x03	000xxx	0011
GotoSecurePosition	000100	0x04	n.a.	
HardStop	000101	0x05	n.a.	
ResetPosition	000110	0x06	n.a.	
ResetToDefault	000111	0x07	n.a.	
RunVelocity	010111	0x17	n.a.	
SetDualPosition	001000	0x08	n.a.	
SetMotorParam	001001	0x09	n.a.	
SetOTParam	010000	0x10	n.a.	
SetStallparam	010110	0x16	n.a.	
SetPosition (16-bit)	001011	0x0B	010xxx	0100
SetPositionShort (1 motor)	001100	0x0C	001001	0101
SetPositionShort (2 motors)	001101	0x0D	101001	0110
SetPositionShort (4 motors)	001110	0x0E	111001	0111
SetPosParam				1001
Sleep	n.a.		n.a.	
SoftStop	001111	0x0F	n.a.	
TestBemf	011111	0x1F	n.a.	
Dynamic ID assignment	010001	0x11	n.a.	
General purpose 2 Data bytes			011000	0000
General purpose 4 Data bytes			101000	0001
Preparation frame			011010	1000

xxx allows to address physically a slave node. Therefore, these dynamic IDs cannot be used for more than eight stepper motors. Only ten ROM pointers are needed for the AMIS-30623.

16.8 LIN Lost Behavior

16.8.1. Introduction

When the LIN communication is broken for a duration of 25000 consecutive frames (= 1,30 s @ 19200 kbit/s) AMIS-30623 sets an internal flag called "LIN lost". The functional behavior depends on the state of OTP bits <SleepEn> and <FailSafe>, and if this loss in LIN communication occurred at (or before) power on reset or in normal powered operation.

16.8.2. Sleep Enable

The OTP bit <SleepEn> enables or disables the entering in low-power sleep mode in case of LIN time-out. Default the entering of the sleep-mode is disabled.

Table 32: Sleep Enable Selection

<SleepEn>	Behavior
0	Entering low-power sleepmode @ LIN – lost DISABLED
1	Entering low-power sleepmode @ LIN – lost ENABLED

16.8.3. Fail Safe Motion

The OTP bit <FailSafe> enables or disables an automatic motion to a predefined safe position. See also Autonomous Motion.

Table 33: Fail Safe Enable Selection

<FailSafe>	Behavior
0	NO motion in case of LIN – lost
1	ENABLES motion to a safe position in case of LIN – lost

16.8.4. Autonomous Motion

AMIS-30623 is able to perform an Autonomous Motion to a preferred position. This positioning starts after the detection of lost LIN communication and in case:

- the OTP bit <FailSafe> = 1.
- RAM register SecPos[10:0] ≠ 0x400

The functional behavior depends if LIN communication is lost during normal operation (see Figure 27 case A) or at (or before) start-up (See Figure 27 case B):

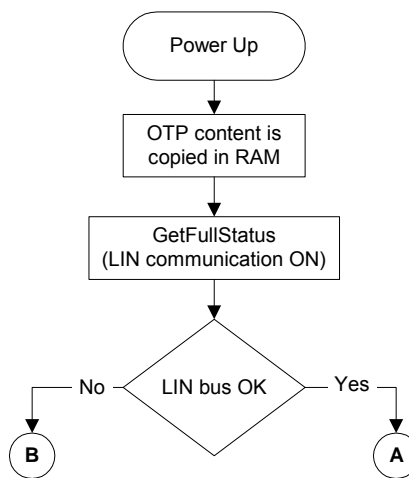

Figure 27: Flow chart power-up of AMIS-30623. 2 cases are illustrated; Case A: LIN lost during operation and Case B: LIN lost at start-up

LIN Lost During Normal Operation

If the LIN communication is lost during normal operation, it is assumed that AMIS-30623 is referenced. In other words the ActPos register contains the “real” actual position. At LIN – lost an absolute positioning to the stored secure position SecPos is done. This is further called Secure Positioning.

Following sequence will be followed. See also [Figure 28](#)

1. “SecPos[10:0]” from RAM register will be used. This can be different from OTP register if earlier LIN master communication has updated this. See also [Secure Position](#) and command [SetMotorParam](#).
2. If the LIN communication is lost AND FailSafe = 0 there will be no secure positioning. Depending on SleepEn AMIS-30623 will enter the STOP state or the SLEEP state. See [Table 32](#).
3. If the LIN communication is lost AND FailSafe = 1 there are 2 possibilities:
 - I. If SecPos[10:0] = 0x400:
no Secure Positioning will be performed
Depending on SleepEn AMIS-30623 will enter the STOP state or the SLEEP state. See [Table 32](#).
 - II. If SecPos[10:0] ≠ 0x400:
Perform a Secure Positioning. This is an absolute positioning (slave knows its ActPos. SecPos[10:0] will be copied in TagPos)

Important remarks:

- (1) The Secure Position has a resolution of 11 bit
- (2) Same behavior in case of HW2 float (= lost LIN address). See also [Hardwired Address HW2](#)

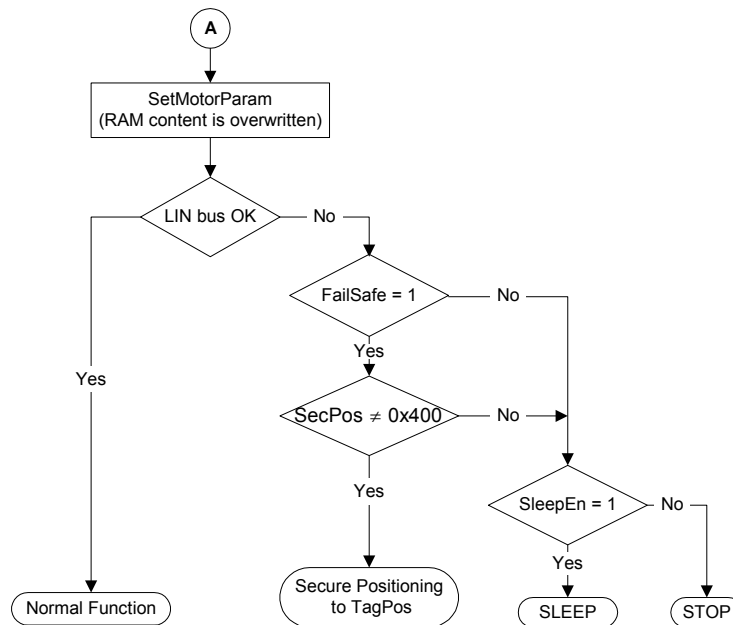

Figure 28: Case A: LIN Lost During Normal Operation

LIN Lost Before or at Power-on

If the LIN communication is lost before or at power on, the ActPos register does not reflect the “real” actual position. So at LIN – lost a referencing is started using DualPositioning. A first negative motion for half the positioner range is initiated until the stall position is reached. The motion parameters stored in OTP will be used for this. After this mechanical end position is reached ActPos will be reset to zero. A second motion will start to the Secure Position also stored in OTP. More details are given below.

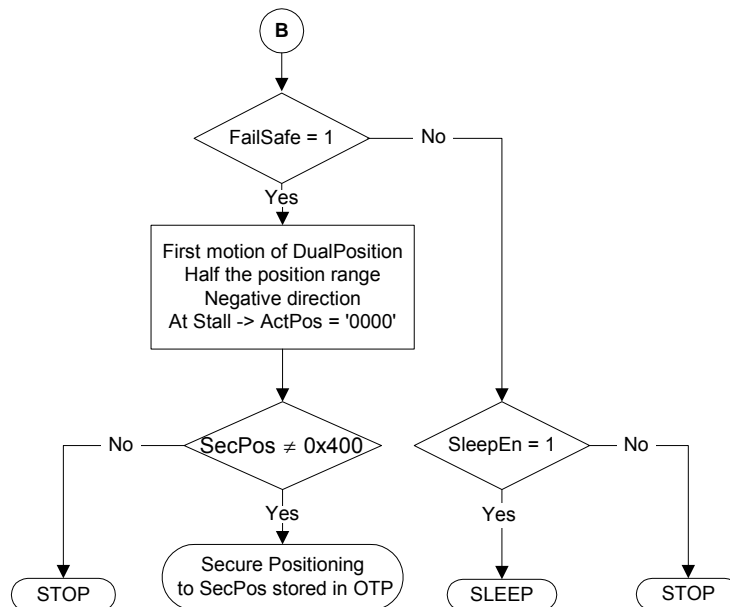

Figure 29: Case B: LIN Lost at or During Start-up

If LIN is lost before or at power on, following sequence will be followed. See also [Figure 29](#)

1. If the LIN communication is lost AND FailSafe = 0 there will be no secure positioning. Depending on SleepEn AMIS-30623 will enter the STOP state or the SLEEP state. See [Table 32](#).
2. If the LIN communication is lost AND FailSafe = 1 a referencing is started using DualPositioning. A negative motion for half the positioner range is initiated until the stall position is reached. The motion parameters stored in OTP will be used for this. After this mechanical end position is reached ActPos will be reset to zero. The direction of the motion is given by the [Shaft bit](#).
 - If SecPos[10:0] = 0x400:
no Second Motion will be performed.
Depending on SleepEn AMIS-30623 will enter the STOP state or the SLEEP state. See [Table 32](#).
 - If SecPos[10:0] ≠ 0x400:
A second motion to SecPos is performed. The direction is given by SecPos[10] in combination with Shaft. Motion is done with parameters from OTP.

Important remarks:

- (1) The Secure Position has only a resolution of 9 bit because only the 9 MSB's will be copied from OTP to RAM. See also [Secure Position](#)
- (2) The motion direction to SecPos is given by the [Shaft bit](#) in OTP
- (3) Same behavior in case of HW2 float (= lost LIN address). See also [Hardwired Address HW2](#)

17.0 LIN Application Commands

17.1 Introduction

The LIN Master will have to use commands to manage the different application tasks the AMIS-30623 can feature. The commands summary is given in the table below.

Table 34: Commands Summary

Command		Frames			Description
Mnemonic	Code	Prep	Read	Write	
Reading command					
GetActualPos	0x00	7, 8	5, 6		Returns the actual position of the motor
GetFullStatus	0x01	7, 8	6		Returns a complete status of the circuit
GetOTPparam	0x02	7, 8	6		Returns the OTP memory content
GetStatus	0x03		5		Returns a short status of the circuit
Writing commands					
GotoSecurePosition	0x04			1	Drives the motor to its secure position
HardStop	0x05			1	Immediate motor stop
ResetPosition	0x06			1	Actual position becomes the zero position
ResetToDefault	0x07				RAM content reset
RunVelocity	0x17			1	Drives motor continuously
SetDualPosition	0x08			4	Drives the motor to 2 different positions with different speeds
SetMotorParam	0x09			4	Programs the motion parameters and values for the current in the motor's coils
SetOTPparam	0x10				Programs (and zaps) a selected byte of the OTP memory
SetStallparam	0x16			4	Programs the motion detection parameters
SetPosition	0x0B			1, 3, 4	Drives the motor to a given position
SetPositionShort (1 m.)	0x0C			2	Drives the motor to a given position (half step mode only)
SetPositionShort (2 m.)	0x0D			2	Drives two motors to 2 given positions (half step only)
SetPositionShort (4 m.)	0x0E			2	Drives four motors to 4 given positions (half step only)
SetPosParam	0x2F			2	Drives the motor to a given position and programs some of the motion parameters.
Service commands					
Sleep				1	Drives circuit into sleep mode
SoftStop	0x0F			1	Motor stopping with a deceleration phase
TestBemf	0x1F			1	Outputs Bemf voltage on pin SW1

These commands are described hereafter, with their corresponding LIN frames. Refer to [LIN Frames](#) for more details on LIN frames, particularly for what concerns dynamic assignment of identifiers. A color coding is used to distinguish between master and slave parts within the frames and to highlight dynamic identifiers. An example is shown below.

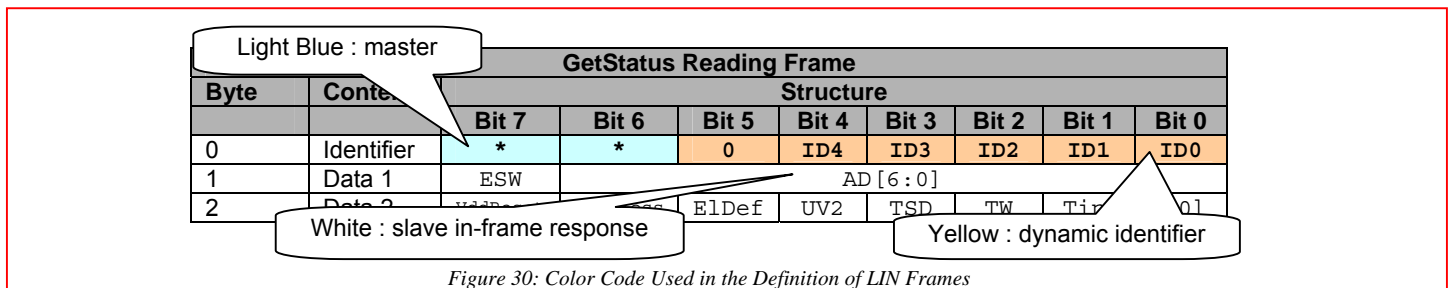

Usually, the AMIS-30623 makes use of dynamic identifiers for general-purpose 2, 4 or 8 bytes writing frames. If dynamic identifiers are used for other purpose, this is acknowledged.

Some frames implement a `Broad` bit that allows to address a command to all the AMIS-30623 circuits connected to the same LIN bus. `Broad` is active when at '0', in which case the physical address provided in the frame is thus not taken into account by the slave nodes.

17.2 Application Commands

GetActualPos

This command is provided to the circuit by the LIN master to get the actual position of the stepper-motor. This position (`ActPos[15:0]`) is returned in signed two's complement 16-bit format. One should note that according to the programmed stepping mode, the LSBs of `ActPos[15:0]` may have no meaning and should be assumed to be '0', as described in [Position Ranges](#). `GetActualPos` also provides a quick status of the circuit and the stepper-motor, identical to that obtained by command [GetStatus](#) (see further).

Note: A `GetActualPosition` command will not attempt to reset any flag. `GetActualPos` corresponds to the following LIN reading frames.

1.) 4 data bytes in-frame response with direct ID (type #5)

Reading Frame									
Byte	Content	Structure							
		Bit 7	Bit 6	Bit 5	Bit 4	Bit 3	Bit 2	Bit 1	Bit 0
0	Identifier	*	*	1	0	ID3	ID2	ID1	ID0
1	Data 1	ESW	AD[6:0]						
2	Data 2	ActPos[15:8]							
3	Data 3	ActPos[7:0]							
4	Data 4	VddReset	StepLoss	ElDef	UV2	TSD	TW	Tinfo[1:0]	

Where:

(*) According to parity computation

ID[5:0]: Dynamically allocated direct identifier. There should be as many dedicated identifiers to this `GetActualPos` command as there are stepper-motors connected to the LIN bus.

2.) One preparing frame prior 4 data bytes in-frame response with `0x3D` indirect ID

Preparing Frame									
Byte	Content	Structure							
		Bit 7	Bit 6	Bit 5	Bit 4	Bit 3	Bit 2	Bit 1	Bit 0
0	Identifier	*	*	0	ID4	ID3	ID2	ID1	ID0
1	Data 1	1	CMD[6:0] = 0x00						
2	Data 2	1	AD[6:0]						

Reading Frame									
Byte	Content	Structure							
		Bit 7	Bit 6	Bit 5	Bit 4	Bit 3	Bit 2	Bit 1	Bit 0
0	Identifier	0	1	1	1	1	1	0	1
1	Data 1	ESW	AD[6:0]						
2	Data 2	ActPos[15:8]							
3	Data 3	ActPos[7:0]							
4	Data 4	VddReset	StepLoss	ElDef	UV2	TSD	TW	Tinfo[1:0]	
5	Data 5	0xFF							
6	Data 6	0xFF							
7	Data 7	0xFF							
8	Data 8	0xFF							

Where:

(*) According to parity computation

GetFullStatus

This command is provided to the circuit by the LIN master to get a complete status of the circuit and the stepper-motor. Refer to [RAM Registers](#) and [Flags Table](#) to see the meaning of the parameters sent to the LIN master.

Note: A GetFullStatus command will attempt to reset flags <TW>, <TSD>, <UV2>, <ElDef>, <StepLoss>, <CPFail>, <OVC1>, <OVC2> and <VddReset>.

GetFullStatus corresponds to 2 successive LIN in-frame responses with 0x3D indirect ID.

Preparing Frame									
Byte	Content	Structure							
		Bit 7	Bit 6	Bit 5	Bit 4	Bit 3	Bit 2	Bit 1	Bit 0
0	Identifier	*	*	0	ID4	ID3	ID2	ID1	ID0
1	Data 1	1	CMD [6:0] = 0x01						
2	Data 1	1	AD [6:0]						

Reading Frame 1									
Byte	Content	Structure							
		Bit 7	Bit 6	Bit 5	Bit 4	Bit 3	Bit 2	Bit 1	Bit 0
0	Identifier	0	1	1	1	1	1	0	1
1	Data 1	1	AD [6:0]						
2	Data 2	Irun [3:0]				Ihold [3:0]			
3	Data 3	Vmax [3:0]				Vmin [3:0]			
4	Data 4	AccShape	StepMode [1:0]		Shaft	Acc [3:0]			
5	Data 5	VddReset	StepLoss	ElDef	UV2	TSD	TW	Tinfo [1:0]	
6	Data 6	Motion [2:0]			ESW	OVC1	OVC2	Stall	CPFail
7	Data 7	0	0	0	0	TimeE	DataE	HeadE	BitE
8	Data 8	AbsThr [3:0]				DelThr [3:0]			

Reading Frame 2										
Byte	Content	Structure								
		Bit 7	Bit 6	Bit 5	Bit 4	Bit 3	Bit 2	Bit 1	Bit 0	
0	Identifier	0	1	1	1	1	1	0	1	
1	Data 1	1	AD [6:0]							
2	Data 2	ActPos [15:8]								
3	Data 3	ActPos [7:0]								
4	Data 4	TagPos [15:8]								
5	Data 5	TagPos [7:0]								
6	Data 6	SecPos [7:0]								
7	Data 7	MinZCross [2:0]			1	DC100	SecPos [10:8]			
8	Data 8	AbsStall	DelStallLo	DelStallHi	MinSamples [2:0]			DC100StEn	PWMJEn	

Where:

(*) According to parity computation

Important: it is not mandatory for the LIN master to initiate the second in-frame response if ActPos, TagPos and SecPos are not needed by the application.

GetOTPparam

This command is provided to the circuit by the LIN master after a preparation frame (see [Preparing frames](#)) was issued, to read the content of an OTP memory segment which address was specified in the preparation frame.

GetOTPparam corresponds to a LIN in-frame response with **0x3D** indirect ID.

Preparing Frame									
Byte	Content	Structure							
		Bit 7	Bit 6	Bit 5	Bit 4	Bit 3	Bit 2	Bit 1	Bit 0
0	Identifier	*	*	0	ID4	ID3	ID2	ID1	ID0
1	Data 1	CMD[6:0] = 0x02							
2	Data 2	AD[6:0]							

Reading Frame									
Byte	Content	Structure							
		Bit 7	Bit 6	Bit 5	Bit 4	Bit 3	Bit 2	Bit 1	Bit 0
0	Identifier	0	1	1	1	1	1	0	1
1	Data 1	OTP byte @0x00							
2	Data 2	OTP byte @0x01							
3	Data 3	OTP byte @0x02							
4	Data 4	OTP byte @0x03							
5	Data 5	OTP byte @0x04							
6	Data 6	OTP byte @0x05							
7	Data 7	OTP byte @0x06							
8	Data 8	OTP byte @0x07							

Where:

(*) According to parity computation

GetStatus

This command is provided to the circuit by the LIN master to get a quick status (compared to that of [GetFullStatus](#) command) of the circuit and of the stepper-motor. Refer to [Flags Table](#) to see the meaning of the parameters sent to the LIN master.

Note: A GetStatus command will attempt to reset flags <TW>, <TSD>, <UV2>, <ElDef>, <StepLoss> and <VddReset>. GetStatus corresponds to a 2 data bytes LIN in-frame response with a direct ID (type #5).

GetStatus Reading Frame									
Byte	Content	Structure							
		Bit 7	Bit 6	Bit 5	Bit 4	Bit 3	Bit 2	Bit 1	Bit 0
0	Identifier	*	*	0	ID4	ID3	ID2	ID1	ID0
1	Data 1	AD[6:0]							
2	Data 2	VddReset	StepLoss	ElDef	UV2	TSD	TW	Tinfo[1:0]	

Where:

(*) According to parity computation

ID[5:0]: Dynamically allocated direct identifier. There should be as many dedicated identifiers to this GetStatus command as there are stepper-motors connected to the LIN bus.

GotoSecurePosition

This command is provided by the LIN master to one or all the stepper-motors to move to the secure position `SecPos[10:0]`. It can also be internally triggered if the LIN bus communication is lost, after an initialization phase, or prior to going into sleep mode. See the [priority encoder](#) description for more details. The priority encoder table also acknowledges the cases where a `GotoSecurePosition` command will be ignored.

`GotoSecurePosition` corresponds to the following LIN writing frame (type #1).

GotoSecurePosition Writing Frame									
Byte	Content	Structure							
		Bit 7	Bit 6	Bit 5	Bit 4	Bit 3	Bit 2	Bit 1	Bit 0
0	Identifier	*	*	0	ID4	ID3	ID2	ID1	ID0
1	Data	1	CMD[6:0] = 0x04						
2	Data	Broad	AD[6:0]						

Where:

(*) according to parity computation

Broad: If Broad = '0' all the stepper motors connected to the LIN bus will reach their secure position

HardStop

This command will be internally triggered when an electrical problem is detected in one or both coils, leading to shutdown mode. If this occurs while the motor is moving, the `<StepLoss>` flag is raised to allow warning of the LIN master at the next `GetStatus` command that steps may have been lost. Once the motor is stopped, `ActPos` register is copied into `TagPos` register to ensure keeping the stop position.

A `hardstop` command can also be issued by the LIN master for some safety reasons. It corresponds then to the following two data bytes LIN writing frame (type #1).

HardStop Writing Frame									
Byte	Content	Structure							
		Bit 7	Bit 6	Bit 5	Bit 4	Bit 3	Bit 2	Bit 1	Bit 0
0	Identifier	*	*	0	ID4	ID3	ID2	ID1	ID0
1	Data	1	CMD[6:0] = 0x05						
2	Data	Broad	AD[6:0]						

Where:

(*) according to parity computation

Broad: If broad = '0' stepper motors connected to the LIN bus will stop

ResetPosition

This command is provided to the circuit by the LIN master to reset `ActPos` and `TagPos` registers to zero. This can be helpful to prepare for instance a relative positioning.

`ResetPosition` corresponds to the following LIN writing frames (type #1).

ResetPosition Writing Frame									
Byte	Content	Structure							
		Bit 7	Bit 6	Bit 5	Bit 4	Bit 3	Bit 2	Bit 1	Bit 0
0	Identifier	*	*	0	ID4	ID3	ID2	ID1	ID0
1	Data	1	CMD[6:0] = 0x06						
2	Data	Broad	AD[6:0]						

Where:

(*) according to parity computation

Broad: If broad = '0' all the circuits connected to the LIN bus will reset their `ActPos` and `TagPos` registers

ResetToDefault

This command is provided to the circuit by the LIN master in order to reset the whole slave node into the initial state. `ResetToDefault` will, for instance, overwrite the RAM with the reset state of the registers parameters (See [RAM Registers](#)). This is another way for the LIN master to initialize a slave node in case of emergency, or simply to refresh the RAM content.

Note: `ActPos` and `TagPos` are not modified by a `ResetToDefault` command.

Important: Care should be taken not to send a `ResetToDefault` command while a motion is ongoing, since this could modify the motion parameters in a way forbidden by the position controller.

`ResetToDefault` corresponds to the following LIN writing frames (type #1).

ResetPosition Writing Frame									
Byte	Content	Structure							
		Bit 7	Bit 6	Bit 5	Bit 4	Bit 3	Bit 2	Bit 1	Bit 0
0	Identifier	*	*	0	ID4	ID3	ID2	ID1	ID0
1	Data	1	CMD[6:0] = 0x07						
2	Data	Broad	AD[6:0]						

Where:

(*) according to parity computation

Broad: If broad = '0' all the circuits connected to the LIN bus will reset to default

RunVelocity

This command is provided to the circuit by the LIN Master in order to put the motor in continuous motion state.

Note: Continuous LIN communication is required. If not Lost LIN is detected and an autonomous motion will start. See also [LIN lost behavior](#).

`RunVelocity` corresponds to the following LIN writing frames (type #1).

RunVelocity Writing Frame									
Byte	Content	Structure							
		Bit 7	Bit 6	Bit 5	Bit 4	Bit 3	Bit 2	Bit 1	Bit 0
0	Identifier	*	*	0	ID4	ID3	ID2	ID1	ID0
1	Data 1	1	CMD[6:0] = 0x17						
2	Data 2	Broad	AD[6:0]						

Where:

(*) according to parity computation

Broad: If broad = '0' all the stepper motors connected to the LIN bus will start continuous motion.

SetDualPosition

This command is provided to the circuit by the LIN master in order to perform a positioning of the motor using two different velocities. See Section [Dual Positioning](#).

Note1 : This sequence cannot be interrupted by another positioning command.

Important: If for some reason $ActPos$ equals $Pos1[15:0]$ at the moment the `SetDualPosition` command is issued, the circuit will enter in deadlock state. Therefore, the application should check the actual position by a `GetPosition` or a [GetFullStatus](#) command prior to start a dual positioning. Another solution may consist of programming a value out of the stepper motor range for $Pos1[15:0]$. For the same reason $Pos2[15:0]$ should not be equal to $Pos1[15:0]$.

`SetDualPosition` corresponds to the following LIN writing frame with **0x3C** identifier (type #4).

SetDualPositioning Writing Frame									
Byte	Content	Structure							
		Bit 7	Bit 6	Bit 5	Bit 4	Bit 3	Bit 2	Bit 1	Bit 0
0	Identifier	0	0	1	1	1	1	0	0
1	Data 1	AppCMD = 0x80							
2	Data 2	1	CMD[6:0] = 0x08						
3	Data 3	Broad	AD[6:0]						
4	Data 4	Vmax[3:0]				Vmin[3:0]			
5	Data 5	Pos1[15:8]							
6	Data 6	Pos1[7:0]							
7	Data 7	Pos2[15:8]							
8	Data 8	Pos2[7:0]							

Where:

Broad: If broad = '0' all the circuits connected to the LIN bus will run the dual positioning
 Vmax[3:0]: Max velocity for first motion
 Vmin[3:0]: Min velocity for first motion and velocity for the second motion
 Pos1[15:0]: First position to be reached during the first motion
 Pos2[15:0]: Relative position of the second motion

SetStallParam()

This commands sets the Motion Detection parameters, and the related Stepper Motor parameters such as the minimum and maximum velocity, the run- and hold current, acceleration and stepmode See [Motion detection](#) for the meaning of the parameters sent by the LIN Master

`SetStallParam` corresponds to a **0x3C** LIN command

SetStallParam Writing Frame									
Byte	Content	Structure							
		Bit 7	Bit 6	Bit 5	Bit 4	Bit 3	Bit 2	Bit 1	Bit 0
0	Identifier	0	0	1	1	1	1	0	0
1	Data 1	AppCMD = 0x80							
2	Data 2	1	CMD[6:0] = 0x16						
3	Data 3	Broad	AD[6:0]						
4	Data 4	Irun[3:0]				Ihold[3:0]			
5	Data 5	Vmax[3:0]				Vmin[3:0]			
6	Data 6	MinSamples[2:0]		Shaft		Acc[3:0]			
6	Data 7	AbsThr[3:0]				RelThr[3:0]			
8	Data 8	MinZCross[2:0]		AccShape	StepMode[1:0]		DC100StEn	PWMJEn	

Where:

Broad: If Broad = '0' all the circuits connected to the LIN bus will set the parameters in their RAMs as requested

SetMotorParam()

This command is provided to the circuit by the LIN master to set the values for the stepper motor parameters (listed below) in RAM. Refer to [RAM Registers](#) to see the meaning of the parameters sent by the LIN master.

Important: If a SetMotorParam occurs while a motion is ongoing, it will modify at once the motion parameters (see [Position Controller](#)). Therefore the application should not change other parameters than V_{max} and V_{min} while a motion is running, otherwise correct positioning cannot be guaranteed.

SetMotorParam corresponds to the following LIN writing frame with **0x3C** identifier (type #4).

SetMotorParam Writing Frame									
Byte	Content	Structure							
		Bit 7	Bit 6	Bit 5	Bit 4	Bit 3	Bit 2	Bit 1	Bit 0
0	Identifier	0	0	1	1	1	1	0	0
1	Data 1	AppCMD = 0x80							
2	Data 2	1	CMD [6:0] = 0x09						
3	Data 3	Broad	AD [6:0]						
4	Data 4	Irun [3:0]				Ihold [3:0]			
5	Data 5	Vmax [3:0]				Vmin [3:0]			
6	Data 6	SecPos [10:8]			Shaft	Acc [3:0]			
7	Data 7	SecPos [7:0]							
8	Data 8	1	PWMfreq	1	AccShape	StepMode [1:0]	1	PWMJEn	

Where:

Broad: If Broad = '0' all the circuits connected to the LIN bus will set the parameters in their RAMs as requested

SetOTPparam()

This command is provided to the circuit by the LIN master to program the content $D [7:0]$ of the OTP memory byte $OTPA [2:0]$, and to zap it.

Important: This command must be sent under a specific V_{bb} voltage value. See parameter V_{bbOTP} in [DC Parameters](#). This is a mandatory condition to ensure reliable zapping.

SetMotorParam corresponds to a **0x3C** LIN writing frames (type #4).

HardStop Writing Frame									
Byte	Content	Structure							
		Bit 7	Bit 6	Bit 5	Bit 4	Bit 3	Bit 2	Bit 1	Bit 0
0	Identifier	0	0	1	1	1	1	0	0
1	Data 1	AppCMD = 0x80							
2	Data 2	1	CMD [6:0] = 0x10						
3	Data 3	Broad	AD [6:0]						
4	Data 4	1	1	1	1	1	OTPA [2:0]		
5	Data 5	D [7:0]							
6	Data 6	0xFF							
7	Data 7	0xFF							
8	Data 8	0xFF							

Where:

Broad: If Broad = '0' all the circuits connected to the LIN bus will set the parameters in their OTP memories as requested

SetPosition()

This command is provided to the circuit by the LIN master to drive one or two motors to a given absolute position. See [Positioning](#) for more details.

The priority encoder table ([See Priority Encoder](#)) acknowledges the cases where a SetPosition command will be ignored.

SetPosition corresponds to the following LIN write frames.

1) Two (2) Data bytes frame with a direct ID (type #3)

SetPosition Writing Frame									
Byte	Content	Structure							
		Bit 7	Bit 6	Bit 5	Bit 4	Bit 3	Bit 2	Bit 1	Bit 0
0	Identifier	*	*	0	ID4	ID3	ID2	ID1	ID0
1	Data 1	Pos [15 :8]							
2	Data 2	Pos [7 :0]							

Where:

(*) According to parity computation

ID[5:0]: Dynamically allocated direct identifier. There should be as many dedicated identifiers to this SetPosition command as there are stepper-motors connected to the LIN bus.

2) Four (4) Data bytes frame with a general purpose identifier (type #1)

SetPosition Writing Frame									
Byte	Content	Structure							
		Bit 7	Bit 6	Bit 5	Bit 4	Bit 3	Bit 2	Bit 1	Bit 0
0	Identifier	*	*	1	0	ID3	ID2	ID1	ID0
1	Data 1	1	CMD [6 :0] = 0x0B						
2	Data 2	Broad	AD [6 :0]						
3	Data 3	Pos [15 :8]							
4	Data 4	Pos [7 :0]							

Where:

(*) According to parity computation

Broad: If broad = '0' all the stepper motors connected to the LIN will must go to Pos [15 :0].

3) Two (2) motors positioning frame with 0x3C identifier (type #4)

SetPosition Writing Frame									
Byte	Content	Structure							
		Bit 7	Bit 6	Bit 5	Bit 4	Bit 3	Bit 2	Bit 1	Bit 0
0	Identifier	0	0	1	1	1	1	0	0
1	Data 1	AppCMD = 0x80							
2	Data 2	1	CMD [6 :0] = 0x0B						
3	Data 3	1	AD1 [6 :0]						
4	Data 4	Pos1 [15 :8]							
5	Data 5	Pos1 [7 :0]							
6	Data 6	1	AD2 [6 :0]						
7	Data 7	Pos2 [15 :8]							
8	Data 8	Pos2 [7 :0]							

Where:

Adn[6:0] : Motor #n physical address (n ∈ {1,2}).

Posn[15:0] : Signed 16-bit position set-point for motor #n.

SetPositionShort()

This command is provided to the circuit by the LIN Master to drive one, two or four motors to a given absolute position. It applies only for half stepping mode ($StepMode[1:0] = "00"$) and is ignored when in other stepping modes. See [Positioning](#) for more details. The physical address is coded on 4 bits, hence `SetPositionShort` can only be used with a network implementing a maximum of 16 slave nodes. These 4 bits are corresponding to the bits $PA[3:0]$ in OTP memory (address $0x02$) See [Physical Address of the Circuit](#). The priority encoder table ([See Priority Encoder](#)) acknowledges the cases where a `SetPositionShort` command will be ignored.

`SetPositionShort` corresponds to the following LIN writing frames

1.) Two (2) data bytes frame for one (1) motor, with specific identifier (type #2)

SetPositionShort Writing Frame									
Byte	Content	Structure							
		Bit 7	Bit 6	Bit 5	Bit 4	Bit 3	Bit 2	Bit 1	Bit 0
0	Identifier	*	*	0	ID4	ID3	ID2	ID1	ID0
1	Data 1	Pos[10:8]			Broad	AD [3:0]			
2	Data 2	Pos [7:0]							

Where:

- (*) According to parity computation
- Broad: If broad = '0' all the stepper motors connected to the LIN bus will go to $Pos[10:0]$..
- ID[5:0]: Dynamically allocated identifier to two data bytes `SetPositionShort` command.

2.) Four (4) data bytes frame for two (2) motors, with specific identifier (type # 2)

SetPositionShort Writing Frame									
Byte	Content	Structure							
		Bit 7	Bit 6	Bit 5	Bit 4	Bit 3	Bit 2	Bit 1	Bit 0
0	Identifier	*	*	1	0	ID3	ID2	ID1	ID0
1	Data 1	Pos1[10:8]			1	AD1[3:0]			
2	Data 2	Pos1[7:0]							
3	Data 3	Pos2[10:8]			1	AD2[3:0]			
4	Data 4	Pos2[7:0]							

Where:

- (*) according to parity computation
- ID[5:0]: Dynamically allocated identifier to four data bytes `SetPositionShort` command.
- Adn[3:0]: Motor #n physical address least significant bits ($n \in [1,2]$).
- Posn[10:0]: Signed 11-bit position set point for Motor #n (see [RAM Registers](#))

3.) Eight (8) data bytes frame for four (4) motors, with specific identifier (type #2)

SetPositionShort Writing Frame									
Byte	Content	Structure							
		Bit 7	Bit 6	Bit 5	Bit 4	Bit 3	Bit 2	Bit 1	Bit 0
0	Identifier	*	*	1	1	ID3	ID2	ID1	ID0
1	Data 1	Pos1[10:8]			1	AD1[3:0]			
2	Data 2	Pos1[7:0]							
3	Data 3	Pos2[10:8]			1	AD2[3:0]			
4	Data 4	Pos2[7:0]							
5	Data 5	Pos3[10:8]			1	AD3[3:0]			
6	Data 6	Pos3[7:0]							
7	Data 7	Pos4[10:8]			1	AD4[3:0]			
8	Data 8	Pos4[7:0]							

Where:

- (*) according to parity computation
- ID[5:0]: Dynamically allocated identifier to eight data bytes `SetPositionShort` command.
- Adn[3:0]: Motor #n physical address least significant bits ($n \in [1,4]$).
- Posn[10:0]: Signed 11-bit position set point for Motor #n (see [RAM Registers](#))

SetPosParam()

This command is provided to the circuit by the LIN Master to drive one motor to a given absolute position. It also sets some of the values for the stepper motor parameters such as minimum and maximum velocity.

SetPosParam corresponds to a Four (4) Data bytes writing LIN frame with specific dynamically assigned identifier (type # 2).

SoftPosParam Writing Frame									
Byte	Content	Structure							
		Bit 7	Bit 6	Bit 5	Bit 4	Bit 3	Bit 2	Bit 1	Bit 0
0	Identifier	*	*	0	ID4	ID3	ID2	ID1	ID0
1	Data 1	Pos[15:8]							
2	Data 2	Pos[7:0]							
3	Data 3	Vmax[3:0]				Vmin[3:0]			
4	Data 4	AbsThr[3:0]				Acc[3:0]			

Where:

(*) according to parity computation

Broad: If broad = '0' all the stepper motors connected to the LIN bus will stop with deceleration.

ID[5:0]: Dynamically allocated direct identifier to 4 Data bytes SetPosParam command. There should be as many dedicated identifiers to this SetPosition command as there are stepper-motors connected to the LIN bus.

Pos [15:0] : Signed 16-bit position set-point.

Sleep

This command is provided to the circuit by the LIN master to put all the slave nodes connected to the LIN bus into sleep mode. If this command occurs during a motion of the motor, TagPos is reprogrammed to SecPos (provided SecPos is different from "100 0000 0000"), or a SoftStop is executed before going to sleep mode. See LIN 1.3 specification and [Sleep Mode](#). The corresponding LIN frame is a master request command frame (identifier **0x3C**) with data byte 1 containing 0x00 while the followings contain 0xFF.

Sleep Writing Frame									
Byte	Content	Structure							
		Bit 7	Bit 6	Bit 5	Bit 4	Bit 3	Bit 2	Bit 1	Bit 0
0	Identifier	0	0	1	1	1	1	0	0
1	Data 1	0x00							
2	Data 2	0xFF							

SoftStop

If a SoftStop command occurs during a motion of the stepper motor, it provokes an immediate deceleration to Vmin (see [Minimum Velocity](#)) followed by a stop, regardless of the position reached. Once the motor is stopped, TagPos register is overwritten with value in ActPos register to ensure keeping the stop position.

Note: a SoftStop command occurring during a DualPosition sequence is not taken into account.

Command SoftStop occurs in the following cases:

- The chip temperature rises above the thermal shutdown threshold (see [DC Parameters](#) and [Temperature Management](#));
- The LIN master requests a SoftStop. Hence SoftStop will correspond to the following two data bytes LIN writing frame (type #1).

SoftStop Writing Frame									
Byte	Content	Structure							
		Bit 7	Bit 6	Bit 5	Bit 4	Bit 3	Bit 2	Bit 1	Bit 0
0	Identifier	*	*	0	ID4	ID3	ID2	ID1	ID0
1	Data 1	1	CMD[6:0] = 0x0F						
2	Data 2	Broad	AD[6:0]						

Where:

(*) according to parity computation

Broad: If broad = '0' all the stepper motors connected to the LIN bus will stop with deceleration.

TestBemf

This command is provided to the circuit by the LIN Master in order to output the Bemf integrator output to the SWI output of the chip. Once activated, it can be stopped only after POR. During the Bemf observation, reading of the SWI state is internally forbidden.

TestBemf corresponds to the following LIN writing frames (type #1).

TestBemf Writing Frame									
Byte	Content	Structure							
		Bit 7	Bit 6	Bit 5	Bit 4	Bit 3	Bit 2	Bit 1	Bit 0
0	Identifier	*	*	0	ID4	ID3	ID2	ID1	ID0
1	Data 1	1	CMD[6:0] = 0x1F						
2	Data 2	Broad	AD[6:0]						

Where:

(*) according to parity computation

Broad: If broad = '0' all the stepper motors connected to the LIN bus will be affected.

18.0 Resistance to Electrical and Electromagnetic Disturbances

18.1 Electrostatic Discharges

Table 35: Absolute Maximum Ratings

Parameter		Min.	Max.	Unit
Vesd ¹	Electrostatic discharge voltage on LIN pin	-4	+4	kV
	Electrostatic discharge voltage on other pins	-2	+2	kV

Notes:

(1) Human body model (100 pF via 1.5 kΩ, according to MIL std. 883E, method 3015.7)

18.2 Electrical Transient Conduction Along Supply Lines

Test pulses are applied to the power supply wires of the equipment implementing the AMIS-30623 (see application schematic), according to ISO 7637-1 document. Operating Classes are defined in ISO 7637-2.

Table 36: Test Pulses and Test Levels According to ISO 7637-1

Pulse	Amplitude	Rise Time	Pulse Duration	Rs	Operating Class
#1	-100V	≤ 1μs	2ms	10Ω	C
#2a	+100V	≤ 1μs	50μs	2Ω	B
#3a	-150V (from +13.5V)	5ns	100ns (burst)	50Ω	A
#3b	+100V (from +13.5V)	5ns	100ns (burst)	50Ω	A
#5b (load dump)	+21.5V (from +13.5V)	≤ 10ms	400ms	≤ 1Ω	C

18.3 EMC

Bulk current injection (BCI), according to ISO 11452-4. Operating Classes are defined in ISO 7637-2.

Table 37: Bulk Current Injection Operation Classes

Current	Operating Class
60mA envelope	A
100mA envelope	B
200mA envelope	C

18.4 Power Supply Micro-interruptions

According to ISO 16750-2

Table 38: Immunity to Power Supply Micro-interruptions

Test	Operating Class
10μs micro-interruptions	A
100μs micro-interruptions	B
5ms micro-interruptions	B
50ms micro-interruptions	C
300ms micro-interruptions	C

19.0 Package Outline

19.1 SOIC-20: Plastic small outline; 20 leads; body width 300mil.

AMIS reference: SOIC300 20 300G

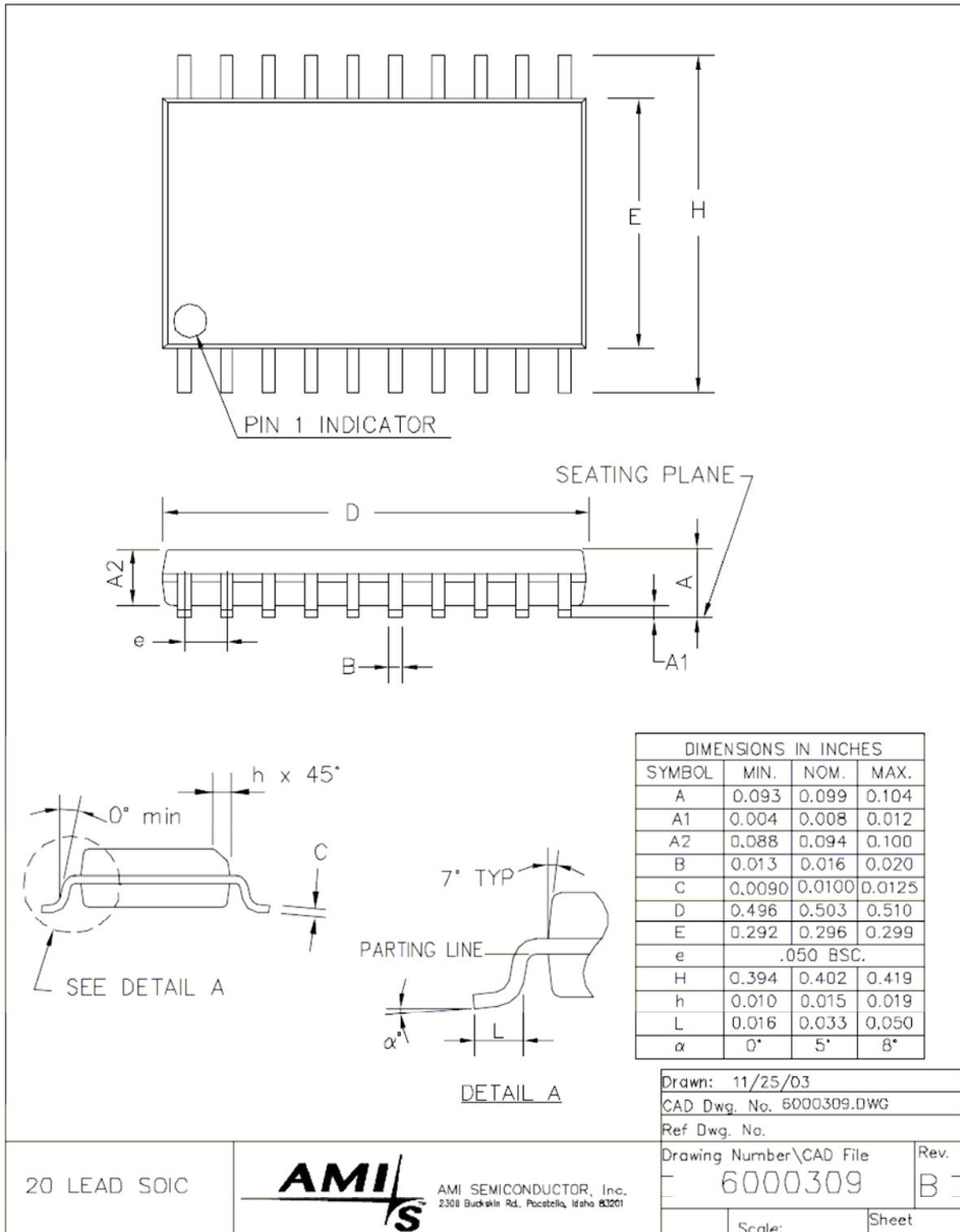

20 LEAD SOIC



AMI SEMICONDUCTOR, Inc.
 2300 Buckskin Rd., Pocatello, Idaho 83201

19.2 NQFP-32: No lead Quad Flat Pack; 32 pins; body size 7 x 7 mm.

AMIS reference: NQFP-32

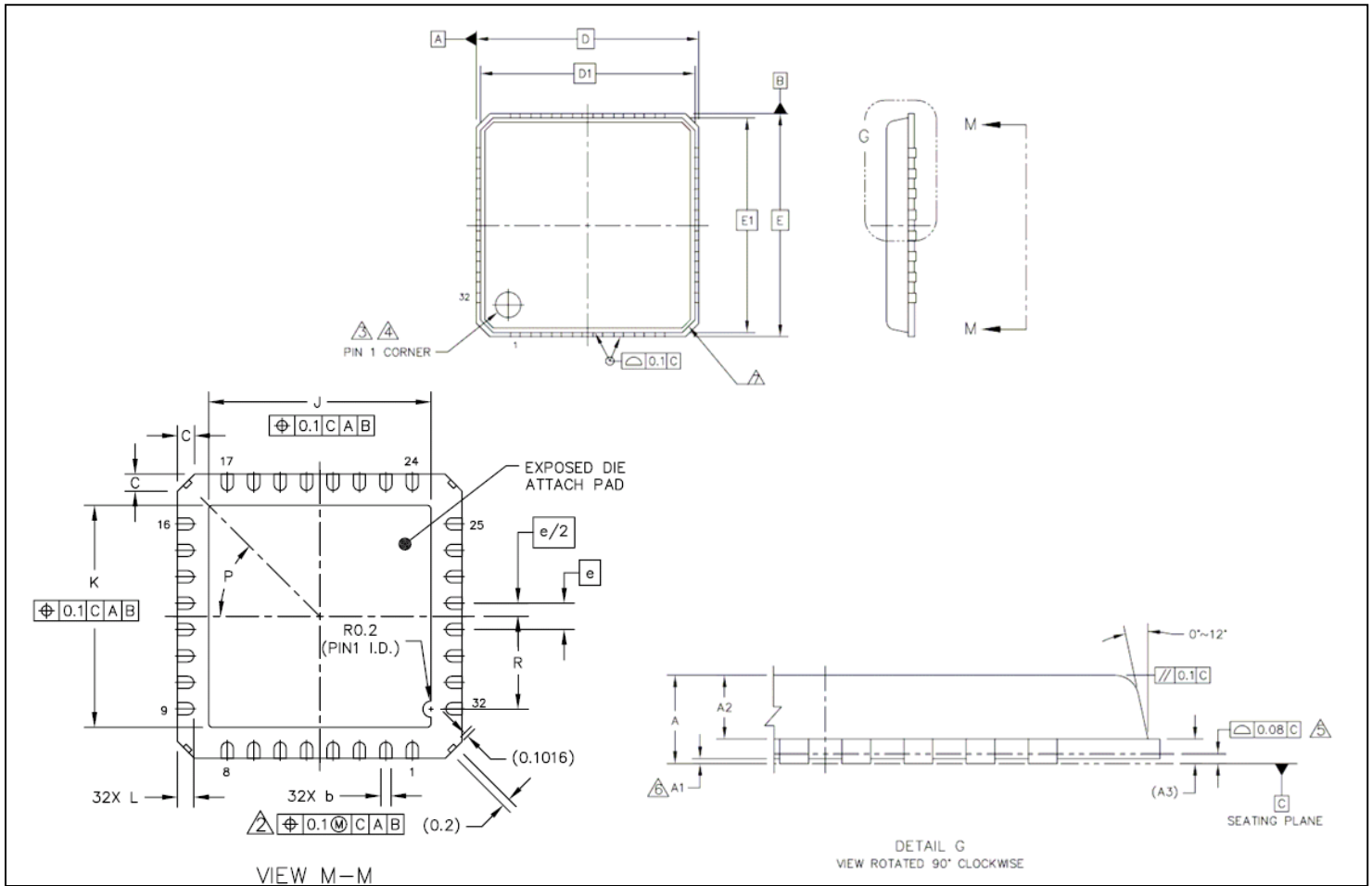

Dimensions:

Dim	Min	Nom	Max	Unit
A	0.8		0.9	mm
A1	0	0.02	0.05	mm
A2	0.576	0.615	0.654	mm
A3		0.203		mm
b	0.25	0.3	0.35	mm
C	0.24	0.42	0.6	mm
D		7		mm
D1		6.75		mm
E		7		mm
E1		6.75		mm
e		0.65		mm
J	5.37	5.47	5.57	mm
K	5.37	5.47	5.57	mm
L	0.35	0.4	0.45	mm
P		45		Degree
R	2.185		2.385	mm

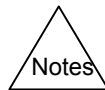

- 2) Dimensions applies to plated terminal and is measured between 0.2 and 0.25 mm from terminal tip.
- 3) The pin #1 indication must be placed on the top surface of the package by using indentation mark or other feature of package body.
- 4) Exact shape and size of this feature is optional
- 5) Applied for exposed pad and terminals. Exclude embedding part of exposed pad from measuring.
- 6) Applied only to terminals
- 7) Exact shape of each corner is optional

7x7 NQFP

20.0 Soldering

20.1 Introduction to Soldering Surface Mount Packages

This text gives a very brief insight to a complex technology. A more in-depth account of soldering ICs can be found in the AMIS “Data Handbook IC26; Integrated Circuit Packages” (document order number 9398 652 90011). There is no soldering method that is ideal for all surface mount IC packages. Wave soldering is not always suitable for surface mount ICs, or for printed-circuit boards with high population densities. In these situations reflow soldering is often used.

20.2 Re-flow Soldering

Re-flow soldering requires solder paste (a suspension of fine solder particles, flux and binding agent) to be applied to the printed-circuit board by screen printing, stencilling or pressure-syringe dispensing before package placement. Several methods exist for reflowing; for example, infrared/convection heating in a conveyor type oven. Throughput times (preheating, soldering and cooling) vary between 100 and 200 seconds depending on heating method. Typical re-flow peak temperatures range from 215 to 250°C. The top-surface temperature of the packages should preferably be kept below 230°C.

20.3 Wave Soldering

Conventional single wave soldering is not recommended for surface mount devices (SMDs) or printed-circuit boards with a high component density, as solder bridging and non-wetting can present major problems. To overcome these problems the double-wave soldering method was specifically developed.

If wave soldering is used the following conditions must be observed for optimal results:

- Use a double-wave soldering method comprising a turbulent wave with high upward pressure followed by a smooth laminar wave.
- For packages with leads on two sides and a pitch (e):
 - Larger than or equal to 1.27mm, the footprint longitudinal axis is preferred to be parallel to the transport direction of the printed-circuit board;
 - Smaller than 1.27mm, the footprint longitudinal axis must be parallel to the transport direction of the printed-circuit board. The footprint must incorporate solder thieves at the downstream end.
- For packages with leads on four sides, the footprint must be placed at a 45° angle to the transport direction of the printed-circuit board. The footprint must incorporate solder thieves downstream and at the side corners.

During placement and before soldering, the package must be fixed with a droplet of adhesive. The adhesive can be applied by screen printing, pin transfer or syringe dispensing. The package can be soldered after the adhesive is cured. Typical dwell time is four seconds at 250°C. A mildly-activated flux will eliminate the need for removal of corrosive residues in most applications.

20.4 Manual Soldering

Fix the component by first soldering two diagonally-opposite end leads. Use a low voltage (24V or less) soldering iron applied to the flat part of the lead. Contact time must be limited to 10 seconds at up to 300°C. When using a dedicated tool, all other leads can be soldered in one operation within two to five seconds between 270 and 320°C.

Table 39: Soldering Process

Package	Soldering Method	
	Wave	Reflow(1)
BGA, SQFP	Not suitable	Suitable
HLQFP, HSQFP, HSOP, HTSSOP, SMS	Not suitable (2)	Suitable
PLCC (3) , SO, SOJ	Suitable	Suitable
LQFP, QFP, TQFP	Not recommended (3)(4)	Suitable
SSOP, TSSOP, VSO	Not recommended (5)	Suitable

- Notes:**
- (1) All surface mount (SMD) packages are moisture sensitive. Depending upon the moisture content, the maximum temperature (with respect to time) and body size of the package, there is a risk that internal or external package cracks may occur due to vaporization of the moisture in them (the so called popcorn effect). For details, refer to the drypack information in the "Data Handbook IC26; Integrated Circuit Packages; Section: Packing Methods."
 - (2) These packages are not suitable for wave soldering as a solder joint between the printed-circuit board and heatsink (at bottom version) can not be achieved, and as solder may stick to the heatsink (on top version).
 - (3) If wave soldering is considered, then the package must be placed at a 45° angle to the solder wave direction. The package footprint must incorporate solder thieves downstream and at the side corners.
 - (4) Wave soldering is only suitable for LQFP, TQFP and QFP packages with a pitch (e) equal to or larger than 0.8mm; it is definitely not suitable for packages with a pitch (e) equal to or smaller than 0.65mm.
 - (5) Wave soldering is only suitable for SSOP and TSSOP packages with a pitch (e) equal to or larger than 0.65mm; it is definitely not suitable for packages with a pitch (e) equal to or smaller than 0.5mm.

21.0 Company or Product Inquiries

For more information about AMI Semiconductor, our technology and our product, visit our Web site at: <http://www.amis.com>.

North America
Tel: +1.208.233.4690
Fax : +1.208.234.6795

Europe
Tel : +32 (0) 55.33.22.11
Fax : +32 (0) 55.31.81.12

22.0 Document History

Table 40: Document history

Version	Date of Version	Modifications/Additions
1.0	July 16, 2002	First non-preliminary issue
2.1	December 5 th , 2005	Complete review
3.0	June 19, 2006	Public release

Devices sold by AMIS are covered by the warranty and patent indemnification provisions appearing in its Terms of Sale only. AMIS makes no warranty, express, statutory, implied or by description, regarding the information set forth herein or regarding the freedom of the described devices from patent infringement. AMIS makes no warranty of merchantability or fitness for any purposes. AMIS reserves the right to discontinue production and change specifications and prices at any time and without notice. AMI Semiconductor's products are intended for use in commercial applications. Applications requiring extended temperature range, unusual environmental requirements, or high reliability applications, such as military, medical life-support or life-sustaining equipment, are specifically not recommended without additional processing by AMIS for such applications. Copyright ©2006 AMI Semiconductor, Inc.