

Sensitive and Standard SCRs, 12A

Main Features

Symbol	Value	Unit
$I_{T(RMS)}$	12	A
V_{DRM}/V_{RRM}	600 to 1000	V
I_{GT}	0.2 to 15	mA

DESCRIPTION

Available either in sensitive or standard gate triggering levels, the 12A SCR series is suitable to fit all modes of control found in applications such as overvoltage crowbar protection, motor control circuits in power tools and kitchen aids, inrush current limiting circuits, capacitive discharge ignition and voltage regulation circuits.

Available in through-hole or surface-mount packages, they provide an optimized performance in a limited space.

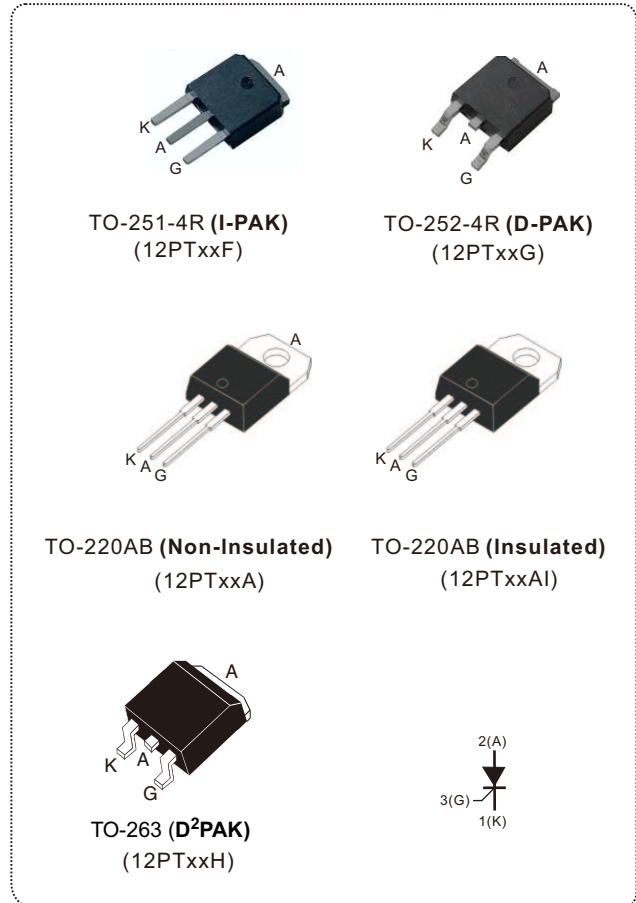

ABSOLUTE MAXIMUM RATINGS					
PARAMETER	SYMBOL	TEST CONDITIONS		VALUE	UNIT
RMS on-state current full sine wave (180° conduction angle)	$I_{T(RMS)}$	TO-251-4R/TO-252-4R/TO-220AB/TO-263	$T_C=105^{\circ}C$	12	A
		TO-220AB insulated	$T_C=90^{\circ}C$		
Average on-state current (180° conduction angle)	$I_{T(AV)}$	TO-251-4R/TO-252-4R/TO-220AB/TO-263	$T_C=105^{\circ}C$	8	A
		TO-220AB insulated	$T_C=90^{\circ}C$		
Non repetitive surge peak on-state current (full cycle, T_j initial = 25°C)	I_{TSM}	F = 50 Hz	t = 20 ms	140	A
		F = 60 Hz	t = 16.7 ms	145	
I ² t Value for fusing	I ² t	t _p = 10 ms		98	A ² s
Critical rate of rise of on-state current $I_G = 2 \times I_{GT}$, t _r ≤ 100ns	di/dt	F = 60 Hz	$T_j = 125^{\circ}C$	50	A/μs
Peak gate current	I _{GM}	T _p = 20 μs	$T_j = 125^{\circ}C$	4	A
Average gate power dissipation	P _{G(AV)}	$T_j = 125^{\circ}C$		1	W
Storage temperature range	T _{stg}			- 40 to + 150	°C
Operating junction temperature range	T _j			- 40 to + 125	

STANDARD ELECTRICAL SPECIFICATIONS (T _J = 25 °C unless otherwise specified)							
SYMBOL	TEST CONDITIONS			12PTxxxx		Unit	
				T	-		
I _{GT}	V _D = 12 V, R _L = 33Ω			Min.	0.5	2	mA
				Max.	5	15	
V _{GT}				Max.	1.3		V
V _{GD}	V _D = V _{DRM} , R _L = 3.3KΩ	T _J = 125°C		Min.	0.2		V
I _H	I _T = 500 mA, gate open			Max.	15	30	mA
I _L	I _G = 1.2 I _{GT}			Max.	30	60	mA
dV/dt	V _D = 67% V _{DRM} , gate open	T _J = 125°C		Min.	40	200	V/μs
V _{TM}	I _{TM} = 24A, t _p = 380 μs	T _J = 25°C		Max.	1.6		V
V _{to}	Threshold voltage			Max.	0.85		V
R _d	Dynamic resistance			Max.	30		mΩ
I _{DRM} I _{RDM}	V _{DRM} = V _{RRM}			Max.	T _J = 25°C	5	μA
					T _J = 125°C	2	mA

SENSITIVE ELECTRICAL CHARACTERISTICS (T _J = 25 °C unless otherwise specified)							
SYMBOL	TEST CONDITIONS			12PTxxxx-S		Unit	
				T	-		
I _{GT}	V _D = 12 V, R _L = 140Ω			Max.	200		μA
				V _{GT}	Max.	0.8	
V _{GD}	V _D = V _{DRM} , R _L = 3.3KΩ, R _{GK} = 220Ω	T _J = 125°C		Min.	0.1		V
V _{RG}	I _{RG} = 10 μA			Min.	8		V
I _H	I _T = 50 mA, R _{GK} = 1 KΩ			Max.	5		mA
I _L	I _G = 1 mA, R _{GK} = 1 KΩ			Max.	6		mA
dV/dt	V _D = 67% V _{DRM} , R _{GK} = 220Ω	T _J = 125°C		Min.	10		V/μs
V _{TM}	I _{TM} = 24A, t _p = 380 μs	T _J = 25°C		Max.	1.6		V
V _{to}	Threshold voltage			Max.	0.85		V
R _d	Dynamic resistance			Max.	30		mΩ
I _{DRM} I _{RDM}	V _{DRM} = V _{RRM} , R _{GK} = 220Ω			Max.	T _J = 25°C	5	μA
					T _J = 125°C	2	mA

DYNAMIC CHARACTERISTICS						
SYMBOL	PARAMETER	TEST CONDITIONS	VALUE			UNIT
			Min.	Typ.	Max.	
t _{gt}	Gate-controlled turn-on time	I _{TM} = 40A, V _D = V _{DRM} (Max.), I _G = 0.1A, dI _G /dt = 5A/μs, T _J = 25°C	-	2.0	-	μS
t _q	Commutated turn-off time	V _D = 67% V _{DRM} , I _{TM} = 20A, V _R = 25V, R _{GK} = 100Ω, dI _{TM} /dt = 30A/μs, dV _D /dt = 50V/μs, T _J = 125°C	-	70	-	μS

THERMAL RESISTANCE					
SYMBOL	Parameter			VALUE	UNIT
R _{th(j-c)}	Junction to case (DC)	IPAK/DPAK/TO-220AB/TO-263		1.3	°C/W
		TO-220AB insulated		4.6	
R _{th(j-a)}	Junction to ambient (DC)	S = 0.5 cm ²	D-PAK	70	°C/W
		S = 1 cm ²	D ² PAK	45	
			I-PAK	100	
			TO-220AB, TO-220AB insulated	60	

S=Copper surface under tab

PRODUCT SELECTOR					
PART NUMBER	VOLTAGE (xx)			SENSITIVITY	PACKAGE
	600 V	800 V	1000 V		
12PTxxA-S/12PTxxAI-S	V	V	V	200 μA	TO-220AB
12PTxxA-T/12PTxxAI-T	V	V	V	0.5~5 mA	TO-220AB
12PTxxA/12PTxxAI	V	V	V	2~15 mA	TO-220AB
12PTxxF-S	V	V	V	200 μA	I-PAK
12PTxxF-T	V	V	V	0.5~5 mA	I-PAK
12PTxxF	V	V	V	2~15 mA	I-PAK
12PTxxG-S	V	V	V	200 μA	D-PAK
12PTxxG-T	V	V	V	0.5~5 mA	D-PAK
12PTxxG	V	V	V	2~15 mA	D-PAK
12PTxxH-S	V	V	V	200 μA	D ² -PAK
12PTxxH-T	V	V	V	0.5~5 mA	D ² -PAK
12PTxxH	V	V	V	2~15 mA	D ² -PAK

ORDERING INFORMATION					
ORDERING TYPE	MARKING	PACKAGE	WEIGHT	BASE Q'TY	DELIVERY MODE
12PTxxA-y	12PTxxA-y	TO-220AB	2.0g	50	Tube
12PTxxAI-y	12PTxxAI-y	TO-220AB (insulated)	2.3g	50	Tube
12PTxxF-y	12PTxxF-y	TO-251-4R (I-PAK)	0.40g	80	Tube
12PTxxG-y	12PTxxG-y	TO-252-4R (D-PAK)	0.38g	80	Tube
12PTxxH-y	12PTxxH-y	TO-263(D ² -PAK)	2.0g	50	Tube

Note: xx = voltage, y = sensitivity

ORDERING INFORMATION SCHEME

12
PT
06
AI
-
S

Current
12 = 12A, $I_{T(RMS)}$

SCR series

Voltage Code
06 = 600V
08 = 800V
10 = 1000V

Package type
A = TO-220AB (non-insulated)
AI = TO-220AB (insulated)
F = TO-251-4R (I-PAK)
G = TO-252-4R (D-PAK)
H = TO-263 (D²PAK)

I_{GT} Sensitivity
S = 70~200 μ A
T = 0.5~5 mA
Blank = 2~15 mA

Fig.1 Maximum average power dissipation versus average on-state current

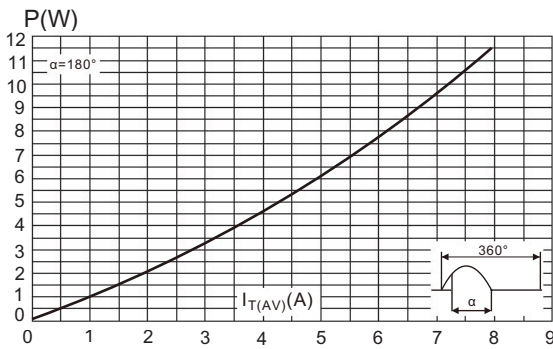

Fig.2 Average and DC on-state current versus case temperature

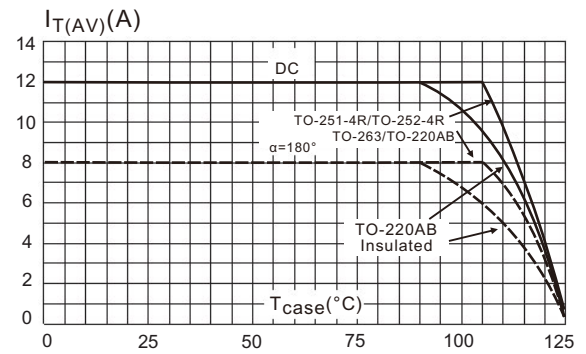

Fig.3 Average and DC on-state current versus ambient temperature (DPAK)

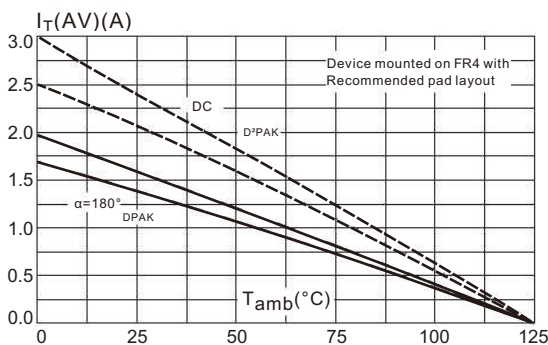

Fig.4 Relative variation of thermal impedance junction to case versus pulse duration

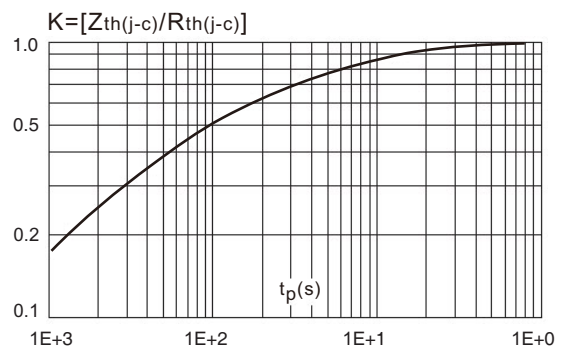

Fig.5 Relative variation of thermal impedance Junction to ambient versus pulse duration (DANK)

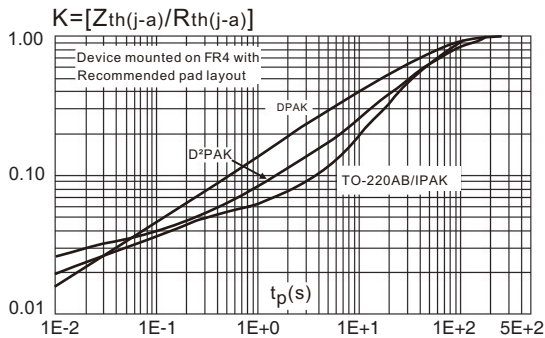

Fig.6 Relative variation of gate trigger and holding current versus junction temperature for $I_{GT}=200\mu A$

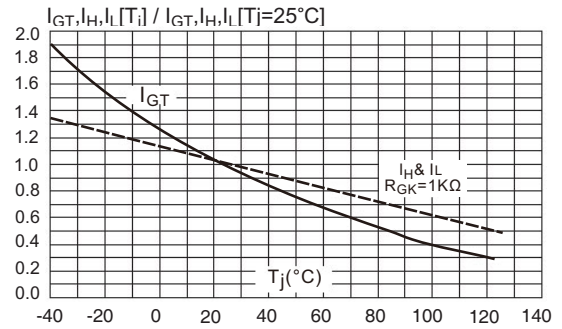

Fig.7 Relative variation of gate trigger and holding current versus junction temperature

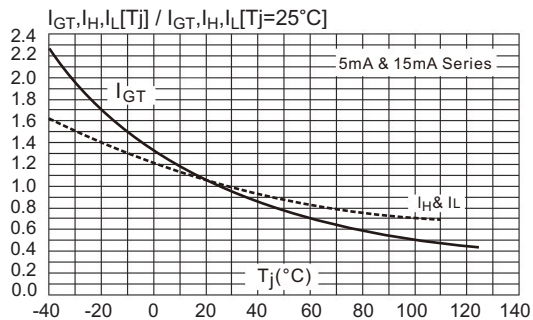

Fig.8 Relative variation of holding current versus gate-cathode resistance (typical values)

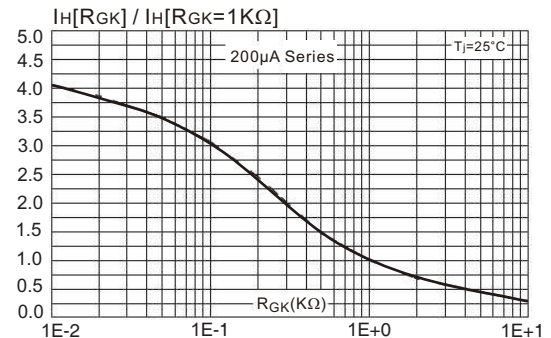

Fig.9 Relative variation of dV/dt immunity versus gate-cathode resistance (Typical values)

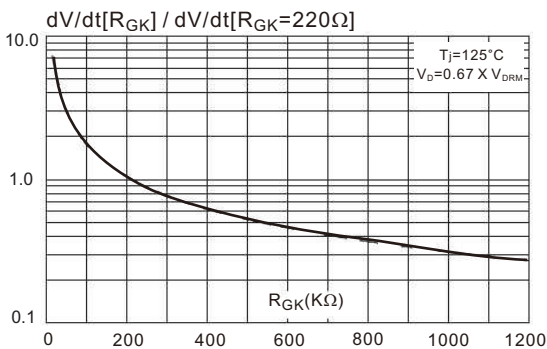

Fig.10 Relative variation of dV/dt immunity versus gate-cathode capacitance (typical values) for $I_{GT}=200\mu A$

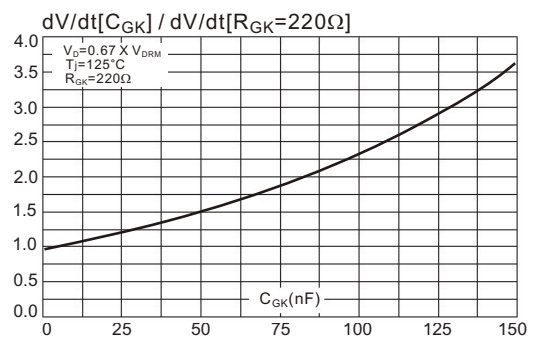

Fig.11 Surge peak on-state current versus number of cycles

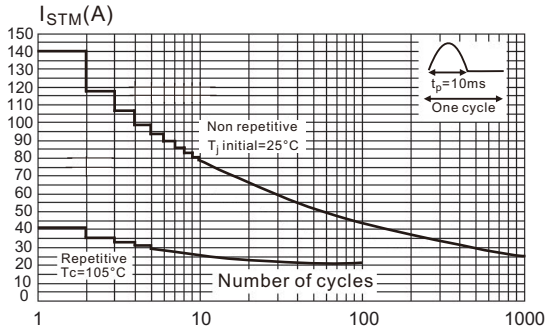

Fig.12 Non-repetitive surge peak on-state current and corresponding values of I²t versus sinusoidal pulse width

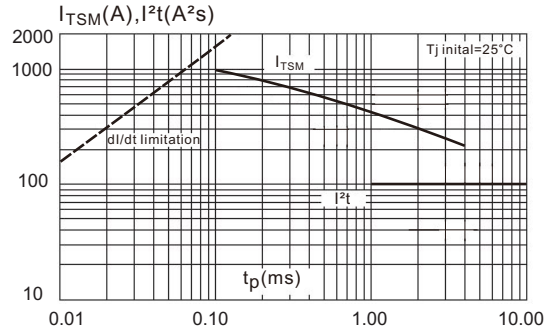

Fig.13 On-state characteristics (maximum values)

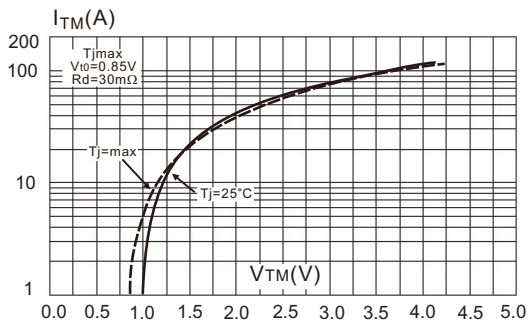
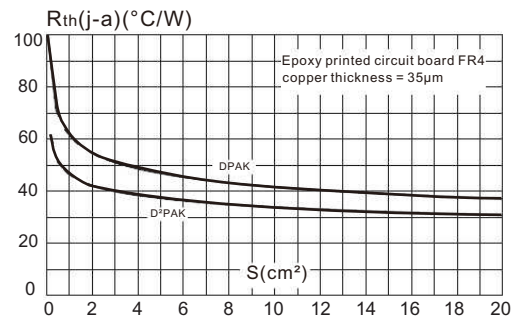
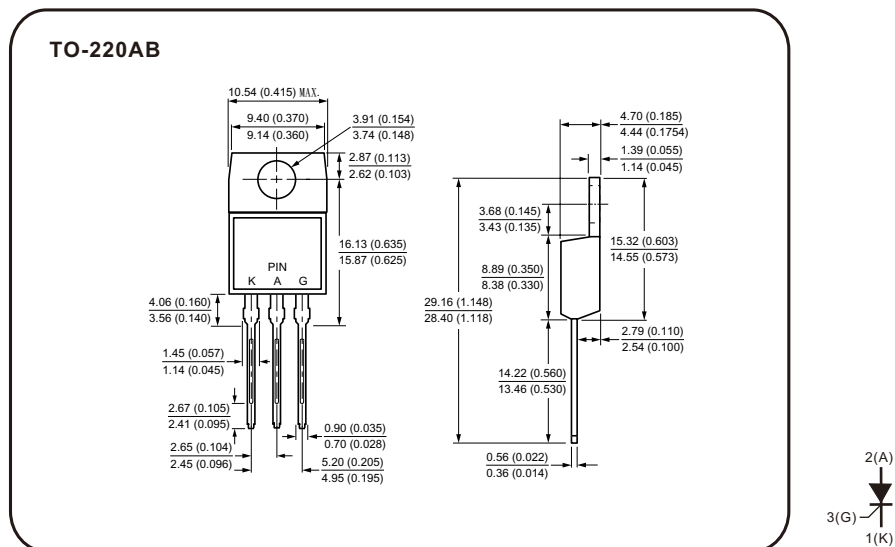

Fig.14 Thermal resistance junction to ambient versus copper surface under tab (D²PAK)



Case Style



All dimensions in millimeters(inches)

Case Style

**TO-251-4R
(I-PAK)**

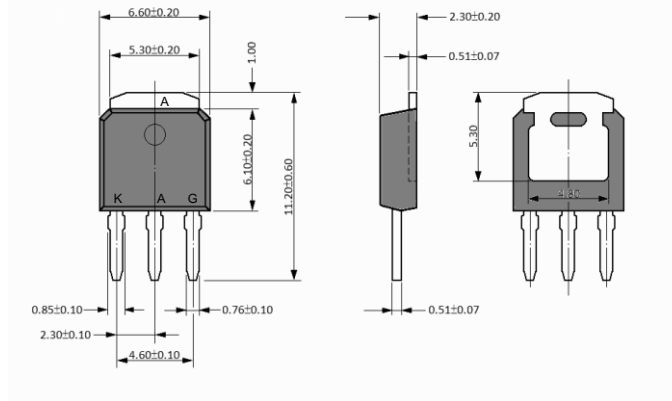

**TO-252-4R
(D-PAK)**

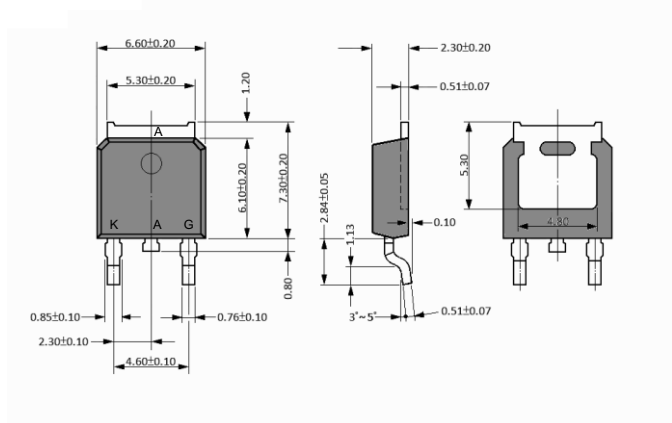

TO-263(D²PAK)

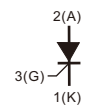
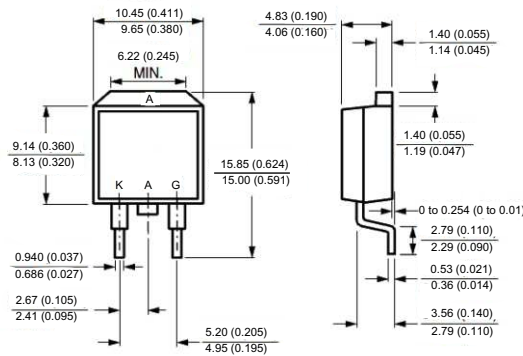

All dimensions in millimeters(inches)