

Dual Channel Input/Output Isolators 15-RACK

(Operational voltage range 24 V \pm 10 %, ripple 10 %p-p max.)

PT CONVERTER

(RMS sensing)

Functions & Features

- Converting an alternating voltage from a potential (voltage) transformer into a standard process signal
- Minimum ripple
- 2 channels available; accomplishing economical and space-saving multi-input processing

Typical Applications

- Centralized monitoring and control of power line and power supply voltages measured at switch boards
- Monitoring abnormal voltage drops for detecting overload

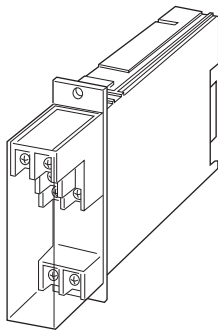

MODEL: 15PE-[1]6-R[2]

ORDERING INFORMATION

- Code number: 15PE-[1]6-R[2]

Specify a code from below for each [1] and [2].

(e.g. 15PE-16-R/Q)

- Specify the specification for option code /Q

(e.g. /C01)

[1] INPUT

Voltage

1: 0 - 110 V AC

5: 0 - 150 V AC

OUTPUT

Voltage

6: 1 - 5 V DC (Load resistance 5000 Ω min.)

POWER INPUT

DC Power

R: 24 V DC

[2] OPTIONS

blank: none

/Q: With options (specify the specification)

SPECIFICATIONS OF OPTION: Q

COATING (For the detail, refer to M-System's web site.)

/C01: Silicone coating

/C02: Polyurethane coating

/C03: Rubber coating

RELATED PRODUCTS

- EXTENDER CARD (model:10EC)

Necessary to adjust span.

GENERAL SPECIFICATIONS

Construction: Rack-mounted; terminal access via screw terminals at the front and via card-edge connector at the rear; terminal cover provided

Connection

Input: M3.5 screw terminals (torque 0.8 N·m)

Output: Card-edge connector and M3.5 screw terminals (torque 0.8 N·m)

Power input: Supplied from card-edge connector

Screw terminal: Nickel-plated steel

Housing material: Flame-resistant resin (black)

Isolation: Input to output or power; ch.1 input to ch.2 input

Input waveform: Up to 15 % of 3rd harmonic content

Overrange output: 0 to 120 %

Zero adjustment: -5 to +5 % (front)

Span adjustment: 95 to 105 % (top)

INPUT SPECIFICATIONS

Frequency: 50 or 60 Hz

Input burden: 0.5 VA max.

Overload capacity: 200 % of rating for 1 minute, 120 % continuous

Operational range: 0 - 120 % of rating

INSTALLATION

Power consumption: Approx. 10 mA

Operating temperature: -5 to +55°C (23 to 131°F)

Operating humidity: 30 to 90 %RH (non-condensing)

Mounting: Standard Rack 15BX

Weight: 180 g (0.40 lb)

PERFORMANCE in percentage of span

- Accuracy: $\pm 0.4\%$
- Temp. coefficient: $\pm 0.02\%/^{\circ}\text{C}$ ($\pm 0.01\%/^{\circ}\text{F}$)
- Response time: ≤ 0.5 sec. (0 - 90 %)
- Ripple: 0.5 %p-p max. (100/120 Hz)
- Line voltage effect: $\pm 0.1\%$ over voltage range
- Insulation resistance: $\geq 100\text{ M}\Omega$ with 500 V DC
- Dielectric strength: 2000 V AC @ 1 minute (input to output or power)
- 2000 V AC @1 minute (ch.1 to ch.2 input)

EXTERNAL DIMENSIONS & TERMINAL ASSIGNMENTS unit: mm (inch)

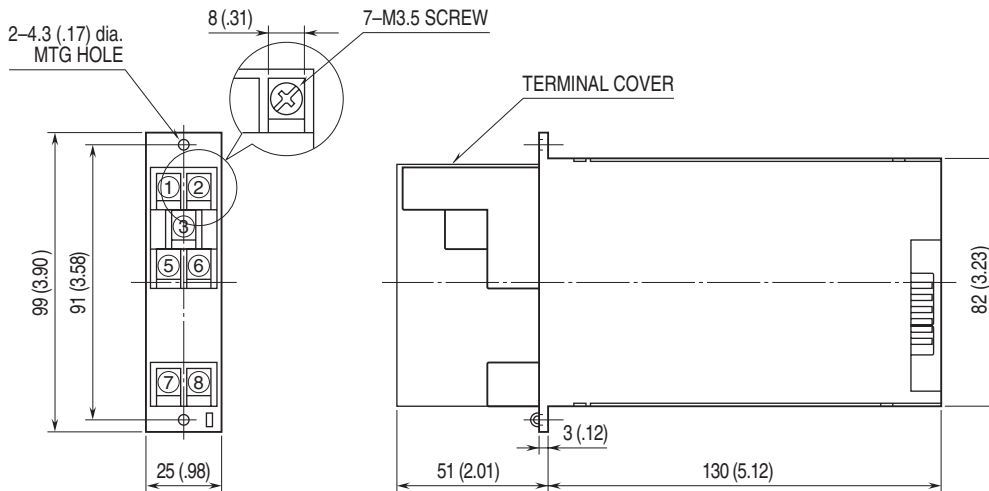

SCHEMATIC CIRCUITRY & CONNECTION DIAGRAM

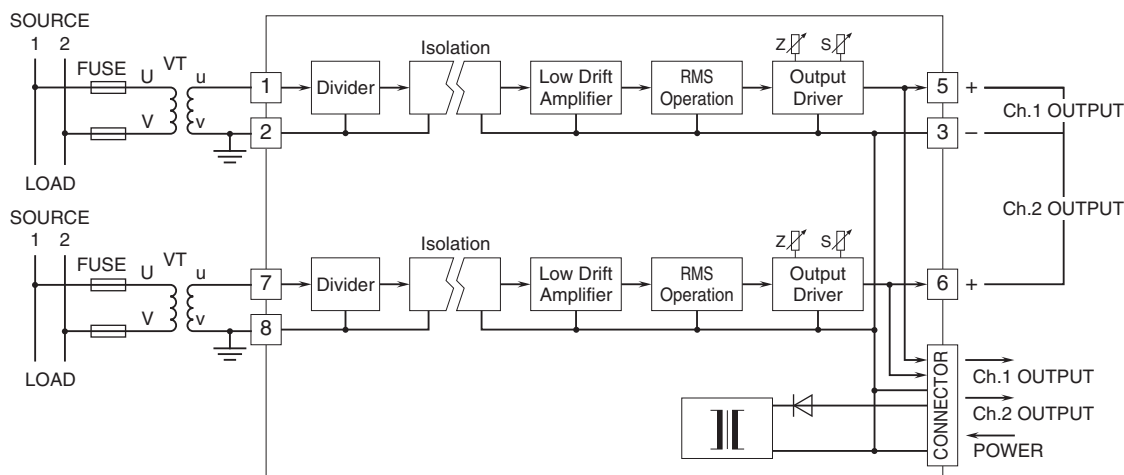

Specifications are subject to change without notice.