

|          |        |           |
|----------|--------|-----------|
| DASH NO. | M CODE | MADE FROM |
|----------|--------|-----------|

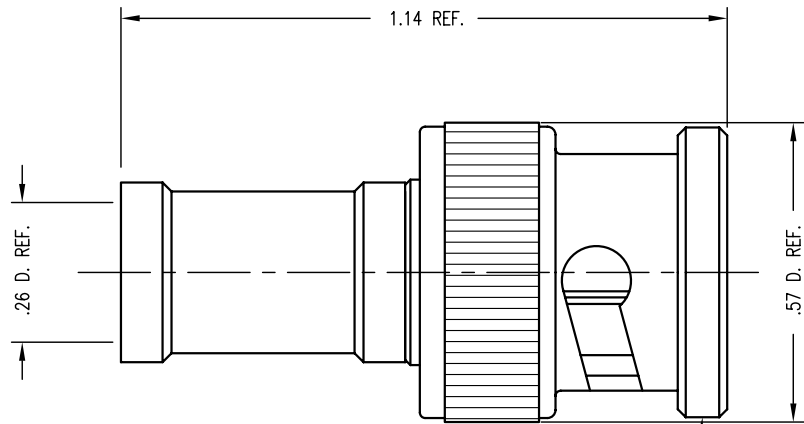

STAMP: KINGS KC-59-232  
YRWK (DATE CODE)

NOTES:

1. FOR USE WITH RG-59, 62 & 210/U CABLES.
2. FOR CABLING INSTRUCTIONS SEE CP-401.
3. FOR CRIMPING USE DIE KTH-2062.
4. INTERFACE PER MIL-STD-348, FIG. 301-1.
5. CENTER CONTACT TO BE SUPPLIED UNASSEMBLED.
6. MATERIALS:
  - INSULATOR-TEFLON, ASTM-D-1457
  - GASKET-SILICONE RUBBER, ZZ-R-765
  - K-GRIP SLEEVE-COMMERCIAL BRONZE, ALLOY 220
  - SPRING WASHER } BER. COP., ASTM-B-196
  - OUTER CONTACT } BER. COP., ASTM-B-196
  - ALL OTHER METAL PARTS-BRASS, ASTM-B16
7. FINISHES:
  - SPRING WASHER-SILVER PLATE PER QQ-S-365
  - CENTER CONTACT-GOLD PLATE PER MIL-G-45204
  - ALL OTHER METAL PARTS-KINGS TARNISH RESISTANT FINISH (TR-5)
8. ELECTRICAL CHARACTERISTICS:
  - NOMINAL IMPEDANCE-50 OHMS
  - WORKING VOLTAGE-500 VRMS
  - FREQUENCY RANGE-DC TO 4 GHZ

REVISIONS

| ISSUE | CHANGES                               |
|-------|---------------------------------------|
| 6     | CN 33552 C<br>REDRAWN<br>JCA 11/22/91 |
| 7     | CN 36876 D<br>MJB 03/22/96            |
| 8     | CN 37798 E<br>TML 03/18/99            |
| K     | REVISED PER ER21926<br>GGR 02/16/2010 |

KC-59-232

JCA2236

CUSTOMER  
SALES DRAWING

SCALE 4:1

APPROX SURFACE AREA

USED ON

REF:

PLUG, BNC

|        |     |      |          |
|--------|-----|------|----------|
| DRAWN  | JCA | DATE | 11/22/91 |
| DESIGN | KAM | DATE | 11/25/91 |
| APPR.  |     | DATE |          |

**KINGS**  
by WINCHESTER

Winchester Electronics  
82 Barnes Industrial  
Road North  
Wallingford, CT 06492

KC-59-232