

TOSHIBA Transistor Silicon NPN Epitaxial Planar Type

# 2SC5090

## VHF~UHF Band Low Noise Amplifier Applications

- Low noise figure, high gain.
- $NF = 1.1\text{dB}$ ,  $|S_{21e}|^2 = 13\text{dB}$  ( $f = 1\text{GHz}$ )

### Absolute Maximum Ratings ( $T_a = 25^\circ\text{C}$ )

Characteristics	Symbol	Rating	Unit
Collector-base voltage	$V_{CBO}$	20	V
Collector-emitter voltage	$V_{CEO}$	10	V
Emitter-base voltage	$V_{EBO}$	1.5	V
Base current	$I_B$	20	mA
Collector current	$I_C$	40	mA
Collector power dissipation	$P_C$	100	mW
Junction temperature	$T_j$	125	$^\circ\text{C}$
Storage temperature range	$T_{stg}$	-55~125	$^\circ\text{C}$

Note: Using continuously under heavy loads (e.g. the application of high temperature/current/voltage and the significant change in temperature, etc.) may cause this product to decrease in the reliability significantly even if the operating conditions (i.e. operating temperature/current/voltage, etc.) are within the absolute maximum ratings. Please design the appropriate reliability upon reviewing the Toshiba Semiconductor Reliability Handbook ("Handling Precautions"/"Derating Concept and Methods") and individual reliability data (i.e. reliability test report and estimated failure rate, etc).

Unit: mm

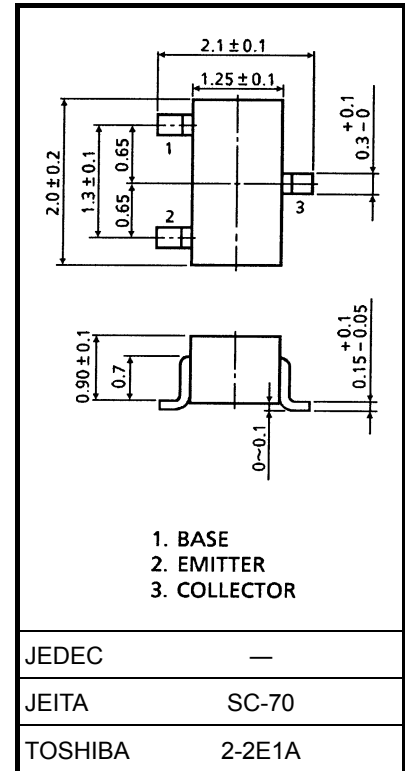

Weight: 0.006 g (typ.)

### Microwave Characteristics ( $T_a = 25^\circ\text{C}$ )

Characteristics	Symbol	Test Condition	Min	Typ.	Max	Unit
Transition frequency	$f_T$	$V_{CE} = 8\text{V}$ , $I_C = 20\text{mA}$	7	10	—	GHz
Insertion gain	$ S_{21e} ^2$ (1)	$V_{CE} = 8\text{V}$ , $I_C = 20\text{mA}$ , $f = 1\text{GHz}$	10	13	—	dB
	$ S_{21e} ^2$ (2)	$V_{CE} = 8\text{V}$ , $I_C = 20\text{mA}$ , $f = 2\text{GHz}$	—	7	—	
Noise figure	NF (1)	$V_{CE} = 8\text{V}$ , $I_C = 5\text{mA}$ , $f = 1\text{GHz}$	—	1.1	2.5	dB
	NF (2)	$V_{CE} = 8\text{V}$ , $I_C = 5\text{mA}$ , $f = 2\text{GHz}$	—	1.7	—	

### Electrical Characteristics ( $T_a = 25^\circ\text{C}$ )

Characteristics	Symbol	Test Condition	Min	Typ.	Max	Unit
Collector cut-off current	$I_{CBO}$	$V_{CB} = 10\text{V}$ , $I_E = 0$	—	—	1	$\mu\text{A}$
Emitter cut-off current	$I_{EBO}$	$V_{EB} = 1\text{V}$ , $I_C = 0$	—	—	1	$\mu\text{A}$
DC current gain	$h_{FE}$ (Note 1)	$V_{CE} = 8\text{V}$ , $I_C = 20\text{mA}$	50	—	160	
Output capacitance	$C_{ob}$	$V_{CB} = 10\text{V}$ , $I_E = 0$ , $f = 1\text{MHz}$ (Note 2)	—	0.7	—	pF
Reverse transfer capacitance	$C_{re}$		—	0.5	0.95	pF

Note 1:  $h_{FE}$  classification R: 50~100, O: 80~160

Note 2:  $C_{re}$  is measured by 3 terminal method with capacitance bridge.

## Marking

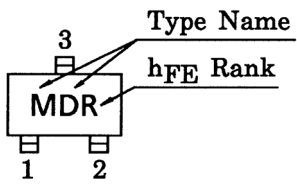

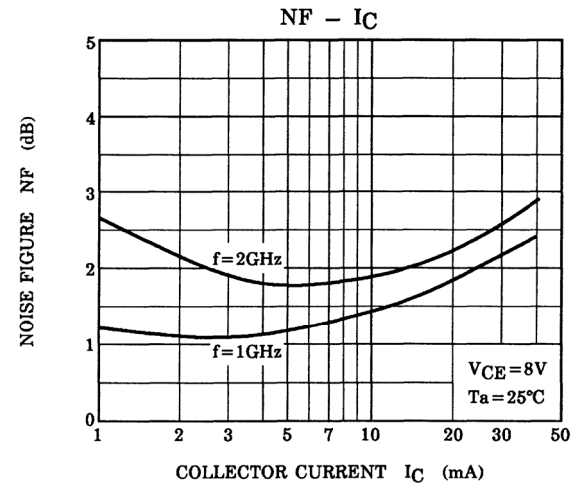
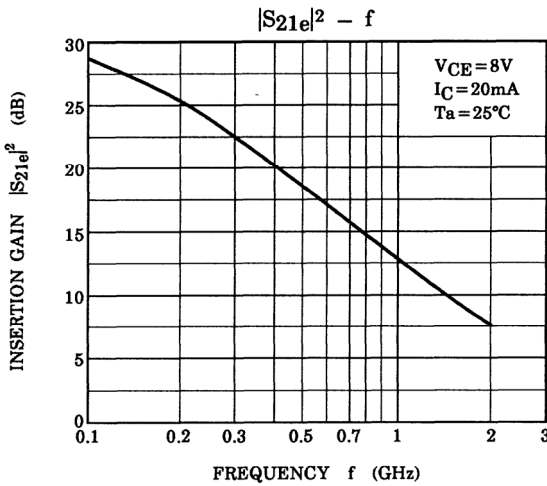
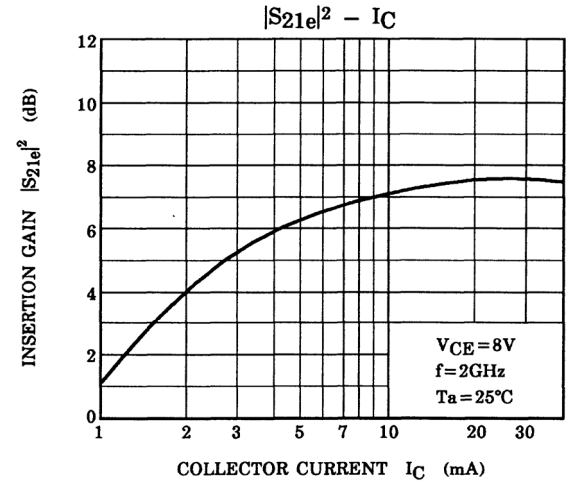
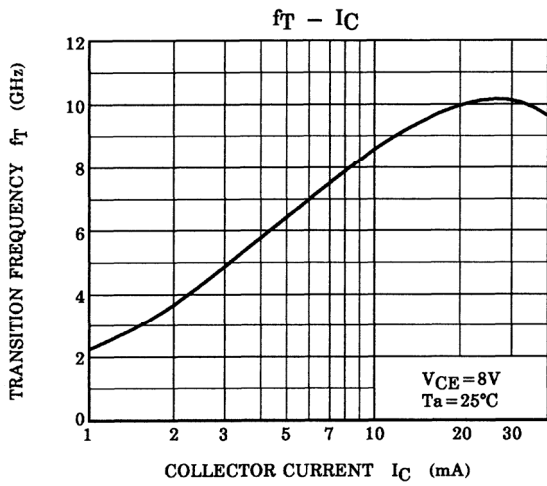
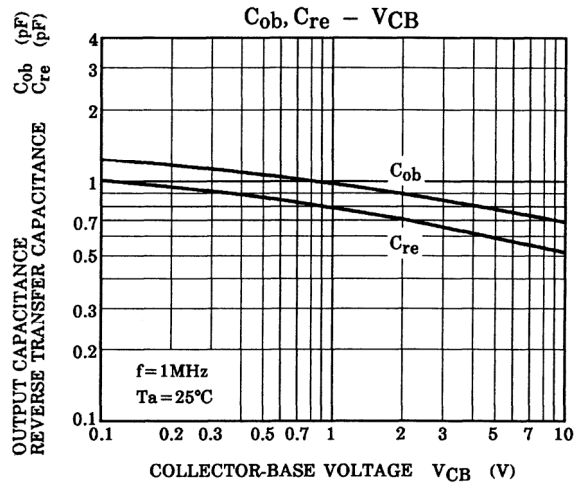
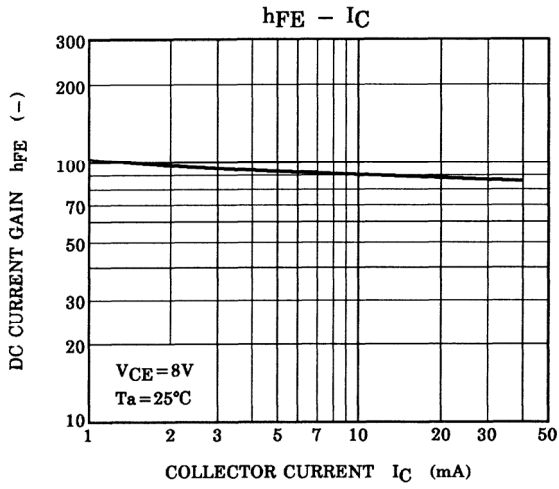

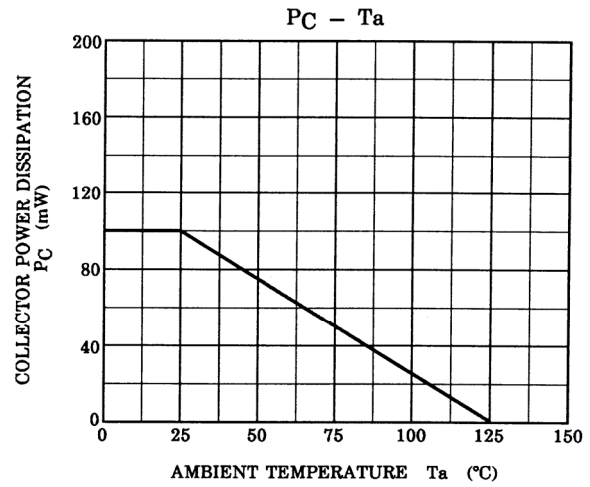
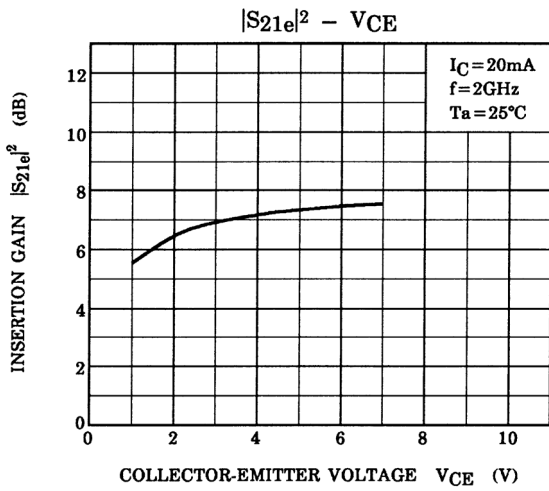

**S-Parameter  $Z_O = 50 \Omega, T_a = 25^\circ C$**

**$V_{CE} = 8 V, I_C = 5 mA$**

Frequency (MHz)	S11		S21		S12		S22	
	Mag.	Ang.	Mag.	Ang.	Mag.	Ang.	Mag.	Ang.
200	0.683	-50.1	10.186	138.3	0.049	62.0	0.773	-30.0
400	0.462	-86.9	7.472	114.6	0.071	54.3	0.556	-39.6
600	0.343	-113.1	5.618	100.9	0.086	53.8	0.448	-41.7
800	0.282	-133.6	4.407	91.7	0.101	55.3	0.392	-41.6
1000	0.249	-151.0	3.663	84.7	0.115	57.2	0.360	-41.7
1200	0.236	-166.6	3.128	78.7	0.131	58.9	0.339	-41.7
1400	0.233	179.7	2.759	73.1	0.150	60.1	0.330	-42.8
1600	0.234	168.3	2.457	68.2	0.168	60.0	0.319	-45.0
1800	0.238	158.6	2.224	63.4	0.185	60.0	0.311	-47.9
2000	0.251	149.6	2.038	59.4	0.203	60.4	0.302	-50.2

**$V_{CE} = 8 V, I_C = 20 mA$**

Frequency (MHz)	S11		S21		S12		S22	
	Mag.	Ang.	Mag.	Ang.	Mag.	Ang.	Mag.	Ang.
200	0.319	-91.9	18.338	116.7	0.033	65.3	0.494	-43.5
400	0.213	-134.2	10.303	99.2	0.054	68.9	0.312	-42.4
600	0.185	-160.0	7.111	90.3	0.076	70.8	0.258	-37.6
800	0.176	-178.2	5.415	84.3	0.098	71.2	0.236	-34.3
1000	0.174	167.8	4.400	79.2	0.120	71.1	0.228	-32.0
1200	0.178	156.8	3.712	74.8	0.143	70.3	0.226	-31.5
1400	0.186	147.5	3.236	70.3	0.168	68.7	0.226	-32.8
1600	0.194	139.7	2.874	66.3	0.190	66.6	0.223	-35.9
1800	0.199	133.7	2.583	62.6	0.211	64.9	0.216	-39.0
2000	0.215	127.8	2.369	58.8	0.232	63.5	0.211	-41.9

**S<sub>11e</sub>**  
**V<sub>CE</sub> = 8V**  
**I<sub>C</sub> = 5mA**  
**T<sub>a</sub> = 25°C**  
 (UNIT : Ω)

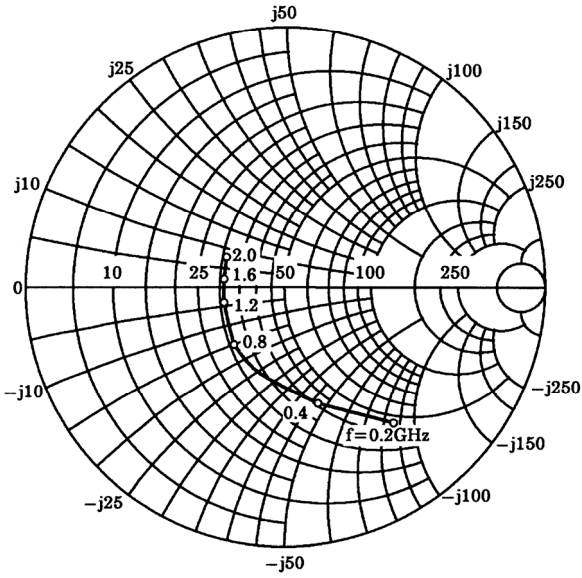

**S<sub>21e</sub>**  
**V<sub>CE</sub> = 8V**  
**I<sub>C</sub> = 5mA**  
**T<sub>a</sub> = 25°C**

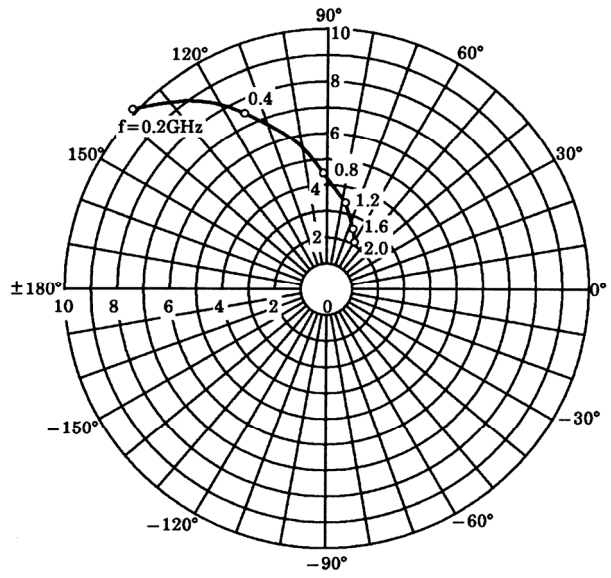

**S<sub>12e</sub>**  
**V<sub>CE</sub> = 8V**  
**I<sub>C</sub> = 5mA**  
**T<sub>a</sub> = 25°C**

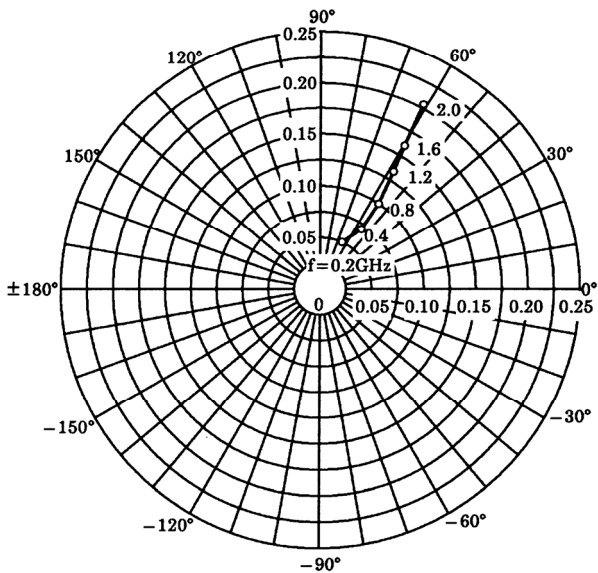

**S<sub>22e</sub>**  
**V<sub>CE</sub> = 8V**  
**I<sub>C</sub> = 5mA**  
**T<sub>a</sub> = 25°C**  
 (UNIT : Ω)

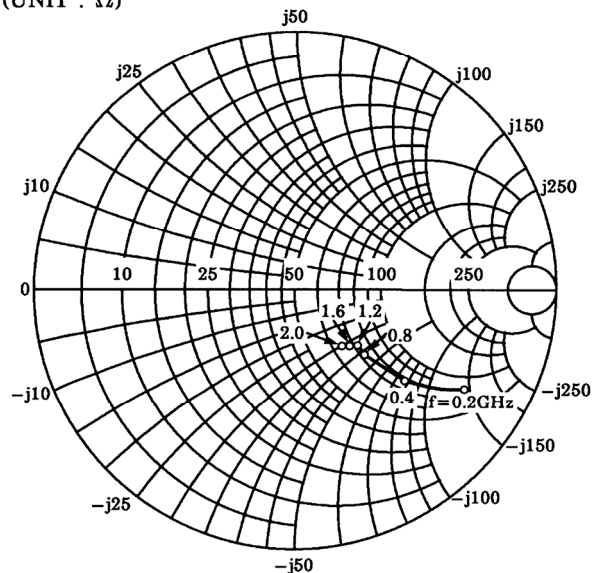

S11e  
 VCE=8V  
 IC=20mA  
 Ta=25°C  
 (UNIT : Ω)

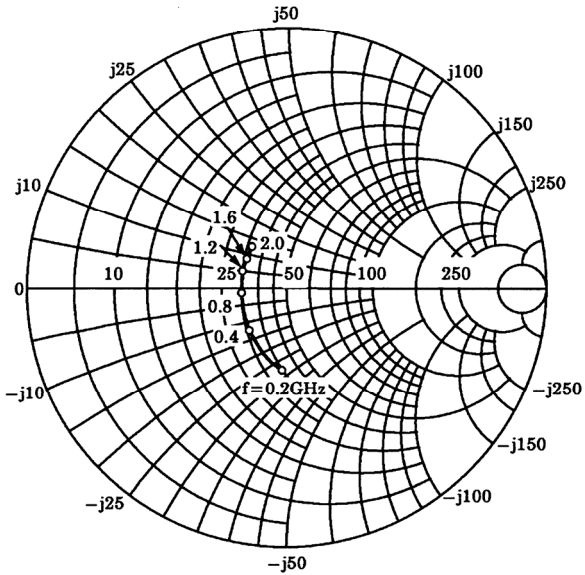

S21e  
 VCE=8V  
 IC=20mA  
 Ta=25°C

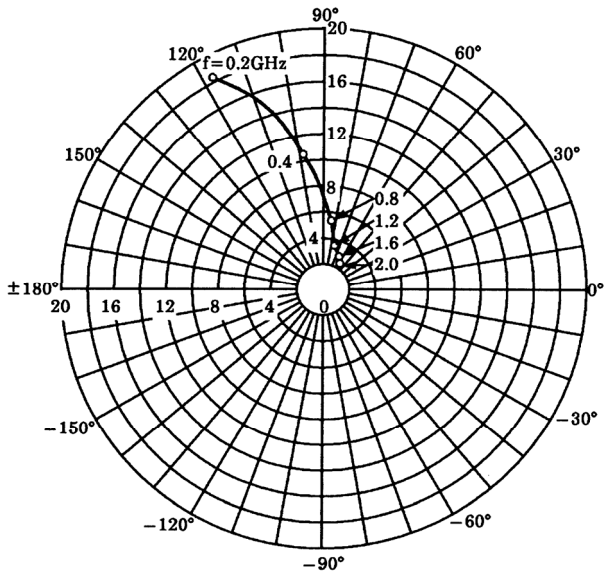

S12e  
 VCE=8V  
 IC=20mA  
 Ta=25°C

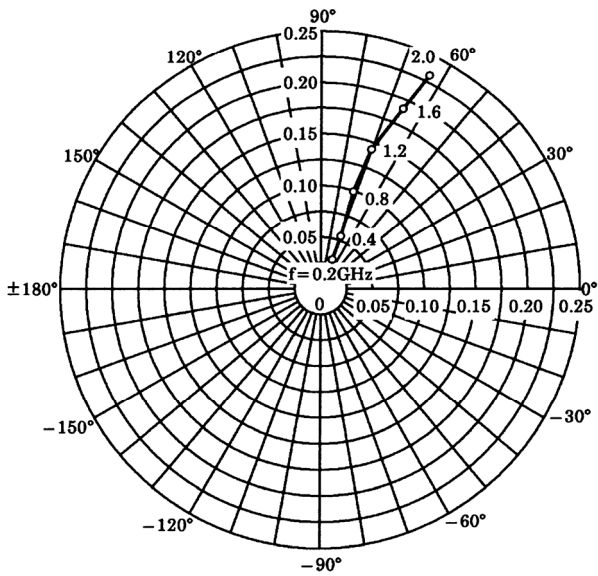

S22e  
 VCE=8V  
 IC=20mA  
 Ta=25°C  
 (UNIT : Ω)

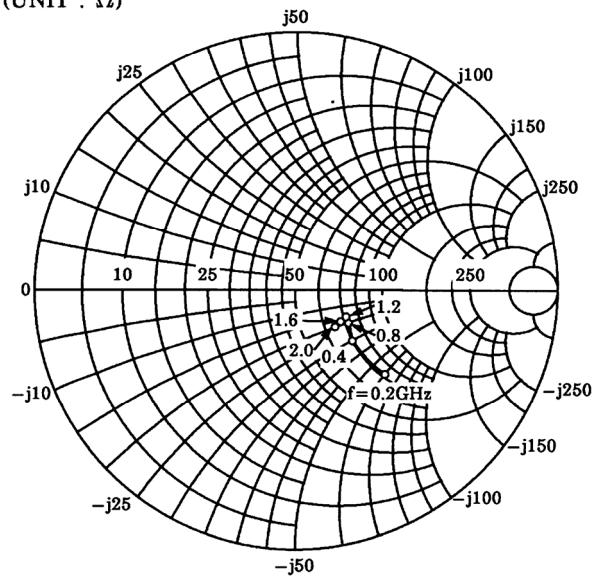

**RESTRICTIONS ON PRODUCT USE**

20070701-EN GENERAL

- The information contained herein is subject to change without notice.
- TOSHIBA is continually working to improve the quality and reliability of its products. Nevertheless, semiconductor devices in general can malfunction or fail due to their inherent electrical sensitivity and vulnerability to physical stress. It is the responsibility of the buyer, when utilizing TOSHIBA products, to comply with the standards of safety in making a safe design for the entire system, and to avoid situations in which a malfunction or failure of such TOSHIBA products could cause loss of human life, bodily injury or damage to property.  
In developing your designs, please ensure that TOSHIBA products are used within specified operating ranges as set forth in the most recent TOSHIBA products specifications. Also, please keep in mind the precautions and conditions set forth in the "Handling Guide for Semiconductor Devices," or "TOSHIBA Semiconductor Reliability Handbook" etc.
- The TOSHIBA products listed in this document are intended for usage in general electronics applications (computer, personal equipment, office equipment, measuring equipment, industrial robotics, domestic appliances, etc.). These TOSHIBA products are neither intended nor warranted for usage in equipment that requires extraordinarily high quality and/or reliability or a malfunction or failure of which may cause loss of human life or bodily injury ("Unintended Usage"). Unintended Usage include atomic energy control instruments, airplane or spaceship instruments, transportation instruments, traffic signal instruments, combustion control instruments, medical instruments, all types of safety devices, etc.. Unintended Usage of TOSHIBA products listed in this document shall be made at the customer's own risk.
- The products described in this document shall not be used or embedded to any downstream products of which manufacture, use and/or sale are prohibited under any applicable laws and regulations.
- The information contained herein is presented only as a guide for the applications of our products. No responsibility is assumed by TOSHIBA for any infringements of patents or other rights of the third parties which may result from its use. No license is granted by implication or otherwise under any patents or other rights of TOSHIBA or the third parties.
- Please contact your sales representative for product-by-product details in this document regarding RoHS compatibility. Please use these products in this document in compliance with all applicable laws and regulations that regulate the inclusion or use of controlled substances. Toshiba assumes no liability for damage or losses occurring as a result of noncompliance with applicable laws and regulations.