



## TSC-75W Series

### Dimmable LED Drivers

### Constant Current

### Aluminum Housing

#### Electrical Specifications

Input Voltage Range:	277 - 480 Nom. Vac (249 - 528 V Min/Max)
Frequency:	50/60 Hz Nom. (47-63 Hz Min/Max)
Power Factor:	>0.90 @ full load, 277V through 480V
Inrush Current:	135.0 Amps max @ 480 Vac, cold start 25°C
Input AC Current:	0.34 A max 277VAC, 0.21 A max 480Vac
Maximum Power:	75W
Line Regulation:	± 1%
Load Regulation:	± 3%
THD:	≤ 20% @ full load
Leakage Current:	0.7 mA 480 Vac 50Hz
Typical Efficiency	85-87% at 480Vac
Turn-on Delay:	1 S typical
Output Current Ripple:	20%
Output Protection:	Over-Voltage, Over-Temperature, and Short Circuit Protection

#### Environmental Specifications

Minimum Starting Temp:	-40°C
Maximum Case Temp.	90°C
Storage Temperature:	-40°C to +85°C
Humidity:	5% to 100%
Cooling:	Convection
Sound Rating:	Class A
MTBF:	380,000 Hours (700 mA model) at 480Vac input, 80% load and 25°C ambient conditions per MIL-HDBK-217F
Lifetime:	50,000 Hours @ Case Temperature = 60°C
Weight:	2.2 lbs. (1.0 kg)



- Total Power: 75 Watts
- Input Voltage: 277-480 Vac Nom.
- UL Dry, Damp & Wet Location Rated
- IP67
- High Power Factor
- UL Type HL Rated
- \* UL8750

#### Constant Current - Product Specifications

Model Number	Output Current (mA ±5%)	Output Voltage Range (Vdc)	Max. Output Power (W)	Typical Efficiency
TSC-075S035ST	350	107-214	75	87%
TSC-075S070ST	700	53-107	75	86%
TSC-075S105ST	1050	36-72	75	87%
TSC-075S140ST	1400	26-53	75	87%
TSC-075S210ST	2100	18-36	75	86%
TSC-075S315ST	3150	12-24	75	85%

#### Dimming Versions - Product Specifications

Model Number	Output Current (mA ±5%)	Output Voltage Range (Vdc)	Max. Output Power (W)	Typical Efficiency
TSC-075S035DT	350	107-214	75	87%
TSC-075S070DT	700	53-107	75	86%
TSC-075S105DT	1050	36-72	75	87%
TSC-075S140DT	1400	26-53	75	87%
TSC-075S210DT	2100	18-36	75	86%
TSC-075S315DT	3150	12-24	75	85%

The output current is adjustable at factory from 50% to 100%.

Class 2: US/Canada US Only



**Note:**

LED drivers are designed and intended to operate LED loads only. Non-LED loading may be outside the specified design limits of our LED drivers, and therefore cannot be covered by any warranty. If you desire to use our LED drivers to operate non-LED loads please contact us to discuss compatibility.

Specifications subject to change without notice.

Rev 8-31-15

**Dimensions - mm**

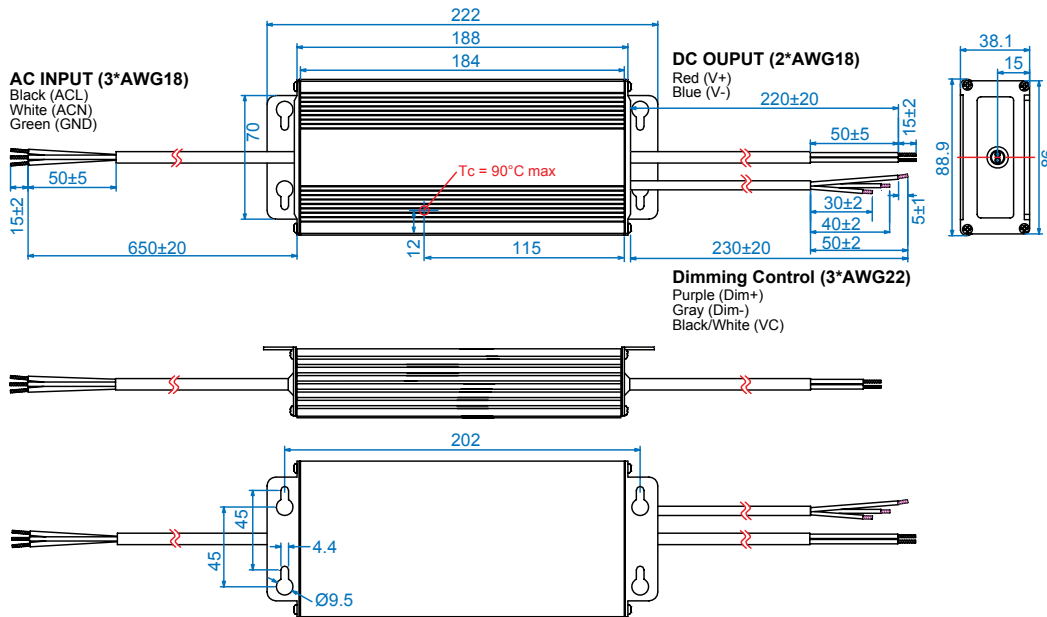

**Derating Curve**

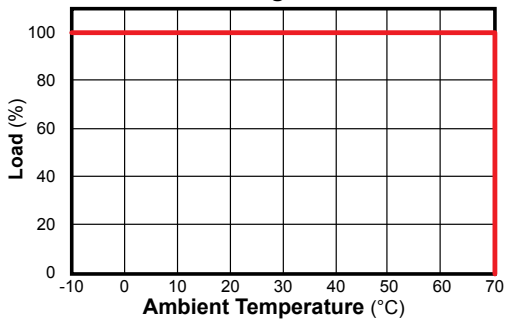

**Lifetime / Case Temperature**

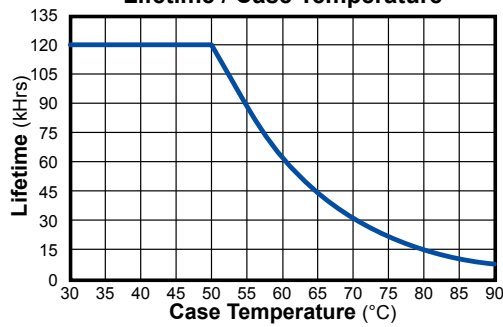

**Power Factor / Output Voltage**

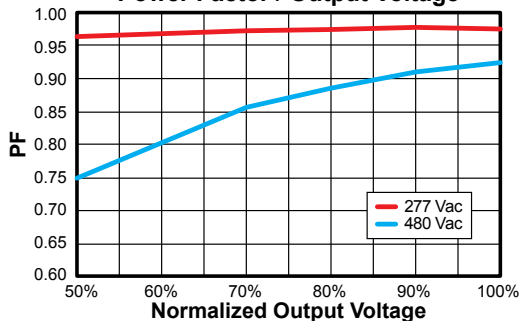

**Efficiency / Load**

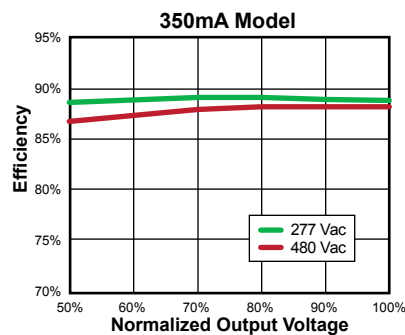

## Dimming Control

Parameters	Minimum	Typical	Maximum
12V output voltage	10.8 V	12 V	13.2 V
Vc source current	10 mA	15 mA	20 mA
Absolute maximum voltage on the 0~10V input pin	-2 V	—	15 V
Source current on 0~10V input pin	150 $\mu$ A	200 $\mu$ A	250 $\mu$ A

The dimmer control is operated from an input signal of 1 – 10 Vdc.

### Implementation with 0-10V Dimming

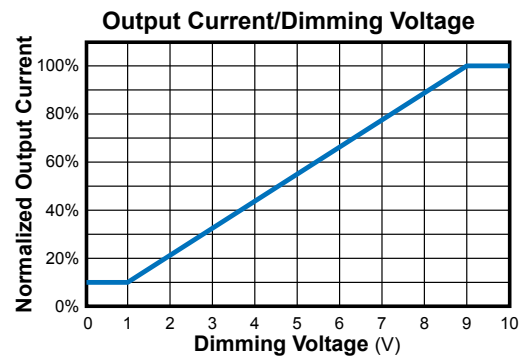
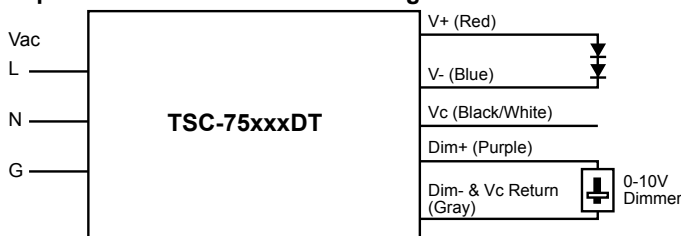

### Notes:

1. The dimmer can also be replaced by an active 0-10V voltage source signal or passive components like resistors and zener.
2. The dimming signal is allowed to be less than 1V, when it is between 0 and 1V, the output level is 10%.
3. Do NOT connect the Gray Wire (Vdim-) to Blue Wire (V-) together.
4. The dimming section is not isolated from the output.
5. Vc is an auxiliary 12V/15mA output.
6. If 0-10V dimming is not used, Dim+ can be either capped-off or connected to Vc.

Safety Certification	Standard
UL/CUL	UL8750, UL1310, UL1012, CAN/CSA-C22.2 No. 223-M91, CSA-C22.2 No. 107.1-01
CE	EN 61347-1, EN61347-2-13
EMC Standard	Notes
EN 55015	Conducted emission Test & Radiated emission Test with 6 dB margin
EN 61000-3-2	Harmonic current emissions: Class C
EN 61000-3-3	Voltage fluctuations & flicker
EN 61000-4-2	Electrostatic Discharge (ESD): 8 kV air discharge, 4 kV contact discharge Level 3, Criteria A
EN 61000-4-3	Radio-Frequency Electromagnetic Field Susceptibility Test-RS Level 3, Criteria A
EN 61000-4-4	Electrical Fast Transient / Burst-EFT Level 3, Criteria A
EN 61000-4-5	Surge Immunity Test: AC Power Line: line to line 4kV, line to earth 6 kV
EN 61000-4-6	Conducted Radio Frequency Disturbances Test-CS Level 3, Criteria A
EN 61000-4-8	Power Frequency Magnetic Field Test 3A/m , Criteria A
EN 61000-4-11	Voltage Dips Criteria B
EN 61547	Electromagnetic Immunity Requirements Applies To Lighting Equipment

### Note:

Disconnect power to LED driver for at least 30 seconds before connecting or disconnecting Driver output and LED Engine. This prevents potential arcing transients that can damage the Engine and Driver. See Hot Plugging in our Driver Application Guide for more information.