

10T6AW4_1.5 Series

10W - Dual/Single Output - 4:1 Wide Input - Isolated & Regulated DC-DC Converter

DC-DC Converter

10 Watt

- ⊕ 4:1 wide input voltage range
- ⊕ Efficiency up to 88%
- ⊕ 1500VDC/500VAC Isolation
- ⊕ Short circuit protection (SCP)
- ⊕ Input under-voltage, over-current, over-voltage protection
- ⊕ Operating temperature: -40°C to +85°C
- ⊕ Industry standard pinout
- ⊕ RoHS compliance
- ⊕ No-load power consumption as low as 0.096W

The 10T6AW4_1.5 series are isolated 10W DC-DC products with 4:1 input voltage, 500VAC/1500VDC isolation, input under-voltage protection, output over-voltage, over-current and short circuit protection, which make them widely applied in industrial control, electricity, instruments and communication fields.



Common specifications

Short circuit protection:	Continuous, automatic recovery
Temperature rise at full load:	40°C TYP
Cooling:	Free air convection
Operation temperature range:	-40°C~+85°C
Storage temperature range:	-55°C ~+125°C
Pin welding resistance temperature:	300°C MAX, 1.5mm from case for 10 sec
Reflow soldering temperature: (Only for models with housing)	Peak temp. ≤245°C, maximum duration time ≤60s at 217°C. For actual application, please refer to IPC/JEDEC J-STD-020D.1.
Vibration:	10-55Hz, 10G, 30 Min. along X, Y and Z
Storage humidity range:	< 95%
Case material:	Aluminium Alloy
MTBF:	>1,000,000 hours
Weight:	6.7g /5.7g (without case)

Input specifications

Item	Test condition	Min	Typ	Max	Units
Input current (full load / no load)	Nominal input voltage				
	• 5VDC input		496/4	508/40	mA
	• 12VDC input		479/3	490/12	mA
	• 15VDC input		474/4	485/15	mA
Reflected ripple current	Nominal input voltage		40		mA
Surge voltage	1sec. max.	-0.7		50	VDC
Starting voltage				9	VDC
Shutdown voltage		5.5	6.5		VDC
Input filter	Pi				
Hot plug	unavailable				
Ctrl* (operating temperature range)	• Models ON	Ctrl pin connected to GND or low level (0-1.2VDC)			
	• Models OFF	Ctrl pin suspended or connected to High level (2.4-12VDC)			
	• Input current when switched off (@25°C)	6mA (TYP)			

* The voltage of Ctrl pin is relative to input pin GND.

Output specifications

Item	Test condition	Min	Typ	Max	Units
Output voltage accuracy			±1	±3	%
Line regulation	Full load, input voltage from low to high		±0.2	±0.5	%
Load regulation	5% to 100% load		±0.5	±1.0	%
Transient recovery time	25% load step change		300	500	µs
Transient response deviation	25% load step change		±3	±5	%
Temperature coefficient	100% load			±0.03	%/°C
Ripple & Noise*	20MHz Bandwidth		50	100	mVp-p
Trim	Nominal input voltage		±5		%Vo
Over Voltage Protection	Input voltage range	110		160	%Vo
Over Voltage Protection	Input voltage range	110	140	200	%Io
Switching frequency**	PWM mode		350		KHz

* Test ripple and noise by "parallel cable" method. See detailed operation instructions at Testing of Power Converter section, application notes.

** This series of products using reduced frequency technology, the switching frequency is test value of full load. When the load is reduced to below 50%, the switching frequency decreases with decreasing load.

Isolation specifications

Item	Test condition	Min	Typ	Max	Units
Isolation voltage (Tested for 1 minute and leakage current less than 5mA)	• Input-output	1500			VDC
	• Input/Output-case (for models with case)	1500			VDC
Isolation resistance (Test at 500VDC)	• Input-output	500			VAC
	• Input/Output-case (for models with case)	500			VAC
Isolation resistance (Test at 500VDC)	• Input-output	1000			MΩ
Isolation capacitance	• Input-output		1000		pF
	• Input/Output-case (for models with case)		1000		pF

Example:

10T6AW4_2405S1.5

10= 10Watt; T6= SMT6; A= series; W4= wide input (4:1) 9-36Vin; 5Vout; S= Single output; 1.5= 1500VDC

10T6W4_1.5 Series

10W - Dual/Single Output - 4:1 Wide Input - Isolated & Regulated
DC-DC Converter

EMC specifications				
EMI	CE	CISPR22/EN55022	CLASS A (bare component) CLASS B (see EMC recommended circuit ①)	
EMI	RE	CISPR22/EN55022	CLASS A (Without External Circuit) CLASS B (see EMC recommended circuit ②)	
EMS	ESD	IEC/EN61000-4-2	Contact ±4KV	perf. Criteria B
EMS	RS	IEC/EN61000-4-3	10V/m	perf. Criteria A
EMS	EFT	IEC/EN61000-4-4	±2KV (see EMC recommended circuit ①)	perf. Criteria B
EMS	Surge	IEC/EN61000-4-5	line to line ±2KV (see EMC recommended circuit ①)	perf. Criteria B
EMS	CS	IEC/EN61000-4-6	3 Vr.m.s	perf. Criteria A

Part Number	Input Voltage [VDC]			Output Voltage [VDC]	Output Current [mA]		Capacitive load [μF, max.]	Efficiency** [%, Typ.]
	Nominal	Range	Max*		Max	Min		
10T6AW4_2405S1.5	24	9-36	40	5	2000	0	2200	84
10T6AW4_2412S1.5	24	9-36	40	12	833	0	680	87
10T6AW4_2415S1.5	24	9-36	40	15	667	0	470	88

* Absolute maximum rating without damage on the converter, but it isn't recommended;

** Efficiency is measured in nominal input voltage and rated output load.

Notes: SMD package without housing: 10TF6AW_xxyyS1.5RP

Typical characteristics

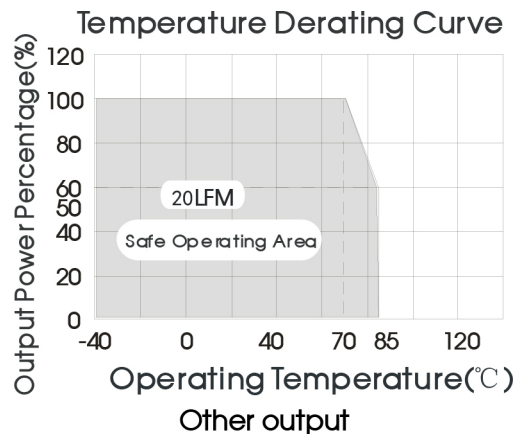
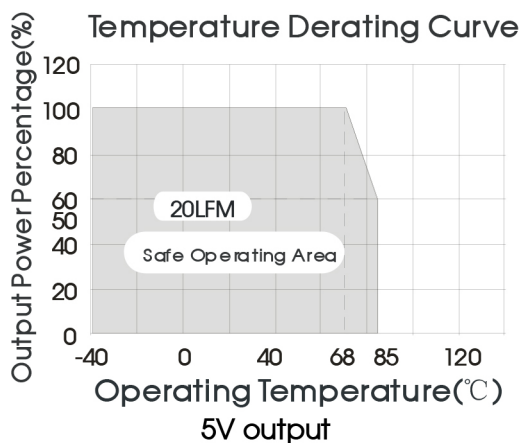

10T6W4_1.5 Series

10W - Dual/Single Output - 4:1 Wide Input - Isolated & Regulated DC-DC Converter

Efficiency

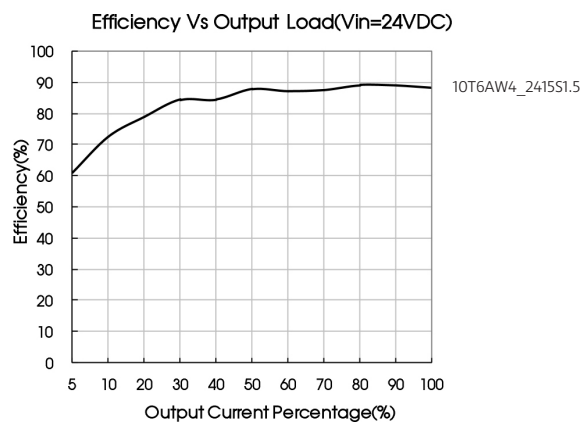
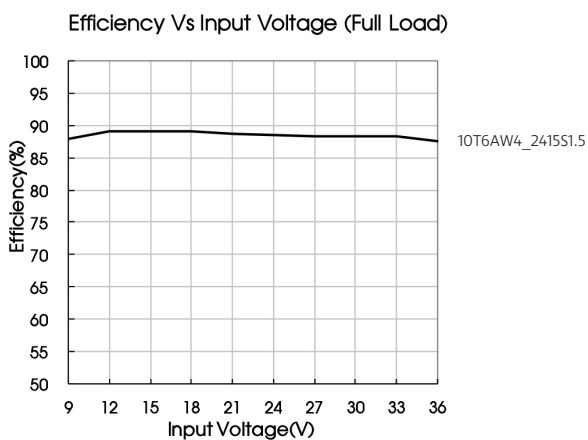
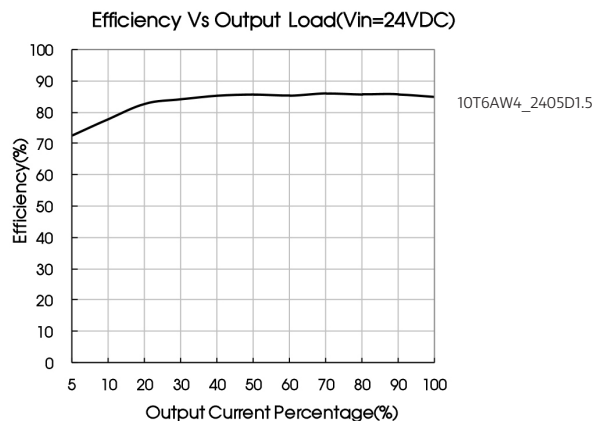
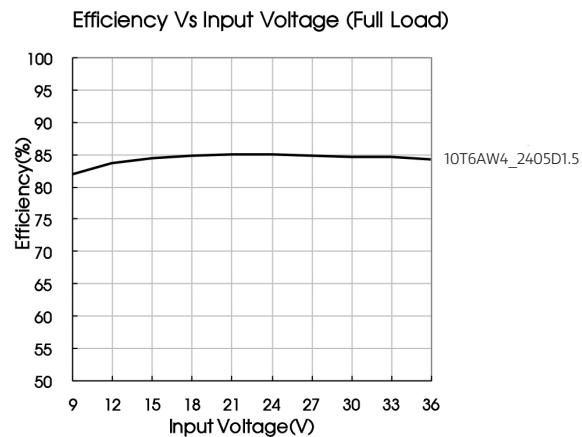

Recommended circuit

Recommended Circuit

All the DC/DC converters of this series are tested according to the recommended circuit (see Fig. 1) before delivery.

If it is required to further reduce input and output ripple, properly increase the input & output of additional capacitors C_{in} and C_{out} or select capacitors of low equivalent impedance provided that the capacitance is no larger than the max. capacitive load of the product.

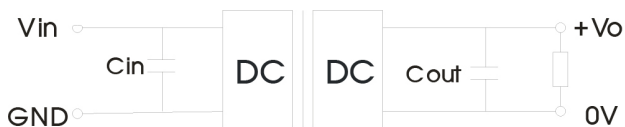

Figure 1

Single output voltage (VDC)	C_{in} (μ F)	C_{out} (μ F)
5/12/15	10	100

10T6W4_1.5 Series

10W - Dual/Single Output - 4:1 Wide Input - Isolated & Regulated DC-DC Converter

EMC solution-recommended circuit

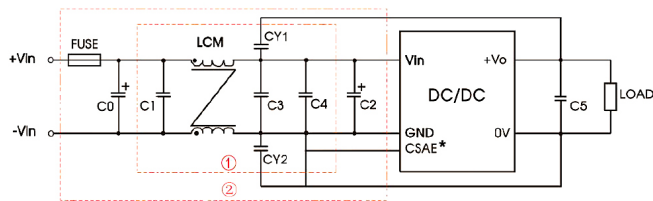

Figure 2

Model	Vin: 24V
FUSE	Choose according to actual input current
C0	680μF/100V
C1/C3/C4	4.7μF/50V
C2	470μF/100V
C5	10μF/25V
LCM	3.3μH
CY1, CY2	1000pF/≥2000VDC

Note:

Part ① in the Fig. 2 is used for EMI test and part ② for EMC filtering; selected based on needs.

For models with housing: the housing should be connected to input pin GND when testing EMC performance.

Trim

Application of Trim and calculation of Trim resistance

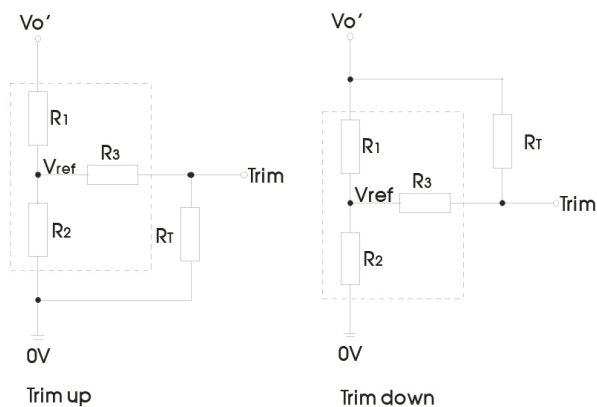

Applied circuits of Trim (Part in broken line is the interior of models)

Calculation formula of Trim resistance:

$$\begin{aligned} \text{up: } R_T &= \frac{\alpha R_2}{R_2 - \alpha} R_3 & \alpha &= \frac{V_{ref}}{V_{o'} - V_{ref}} R_1 \\ \text{down: } R_T &= \frac{\alpha R_1}{R_1 - \alpha} R_3 & \alpha &= \frac{V_{o'} - V_{ref}}{V_{ref}} R_2 \end{aligned}$$

R_T is Trim resistance, α is a self-defined parameter, with no real meaning.
 $V_{o'}$ for the actual needs of the up or down regulated voltage

Vout(VDC)	R1(KΩ)	R2(KΩ)	R3(KΩ)	Vref(V)
5	2.94	2.87	15	2.5
12	11	2.87	33	2.5
15	14.5	2.87	15	2.5

It is not allowed to connect modules output in parallel to enlarge the power.

10T6W4_1.5 Series

10W - Dual/Single Output - 4:1 Wide Input - Isolated & Regulated
DC-DC Converter

Mechanical dimensions with housing

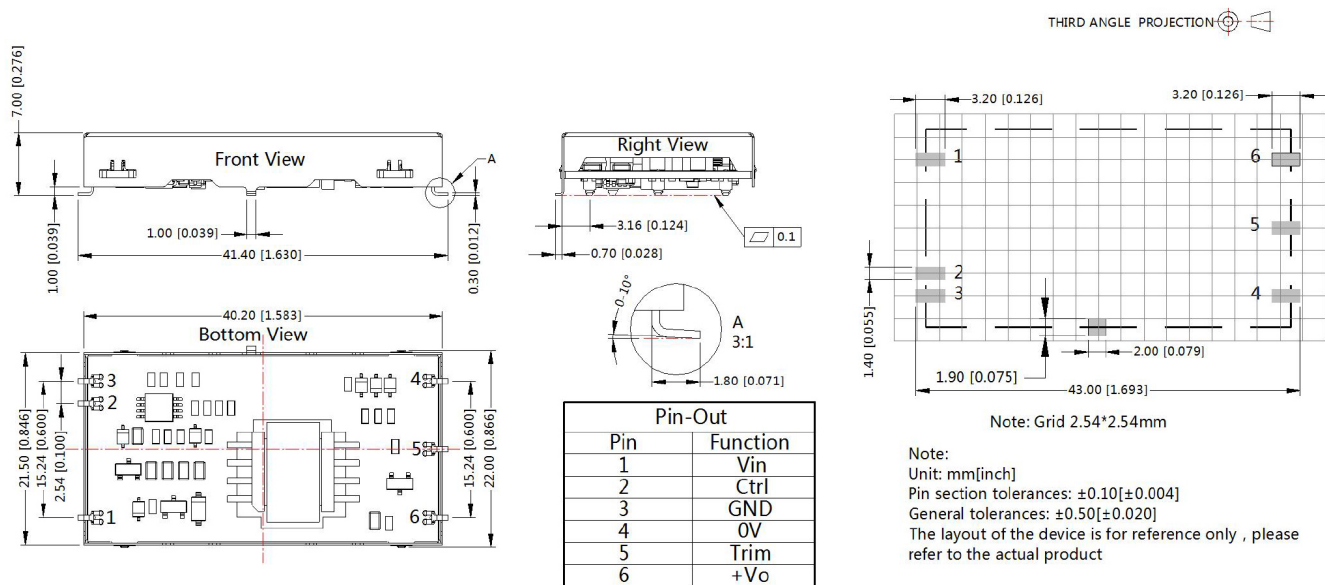

Mechanical dimensions without housing

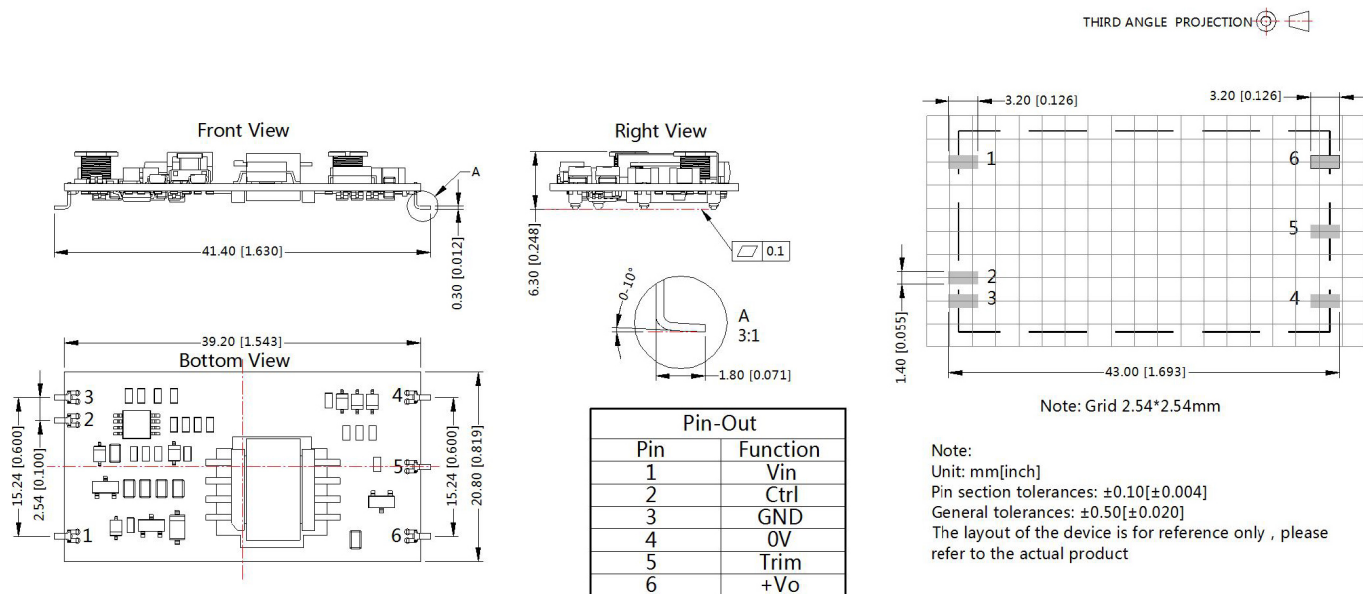

Note:

1. The maximum capacitive load offered were tested at input voltage range and full load.
2. Unless otherwise specified, parameters in this datasheet were measured under the conditions of $T_a=25^\circ\text{C}$, humidity<75%RH with nominal input voltage and rated output load.
3. All index testing methods in this datasheet are based on Company's corporate standards.
4. We can provide product customization service, please contact our technicians directly for specific information.
5. Products are related to laws and regulations
6. Our products shall be classified according to ISO14001 and related environmental laws and regulations, and shall be handled by qualified units.