

## LP3981 Micropower, 300mA Ultra Low-Dropout CMOS Voltage Regulator

Check for Samples: [LP3981](#)

### FEATURES

- Small, Space Saving VSSOP-8
- Low Thermal Resistance in WSON-6 Package Gives Excellent Power Capability
- Logic Controlled Enable
- Stable with Ceramic and High Quality Tantalum Capacitors
- Fast Turn-On
- Thermal Shutdown and Short-Circuit Current Limit

### KEY SPECIFICATIONS

- 2.5 to 6.0V Input Range
- 300mA Output
- 60dB PSRR at 1kHz
- $\leq 1\mu\text{A}$  Quiescent Current when Shut Down
- Fast Turn-On Time: 120  $\mu\text{s}$  (Typ.) with  $C_{\text{BYPASS}} = 0.01\mu\text{F}$
- 132mV Typ Dropout with 300mA Load
- 35 $\mu\text{V}_{\text{rms}}$  Output Noise over 10Hz to 100kHz
- $-40$  to  $+125^\circ\text{C}$  Junction Temperature Range for Operation
- 2.5V, 2.7V, 2.8V, 2.83V, 3.0V, 3.03V, and 3.3V Outputs Standard

### APPLICATIONS

- CDMA Cellular Handsets
- Wideband CDMA Cellular Handsets
- GSM Cellular Handsets
- Portable Information Appliances
- Tiny 3.3V  $\pm 5\%$  to 2.5V, 300mA Converter

### DESCRIPTION

The LP3981's performance is optimized for battery powered systems to deliver ultra low noise, extremely low dropout voltage and low quiescent current. Regulator ground current increases only slightly in dropout, further prolonging the battery life.

Power supply rejection is better than 60 dB at low frequencies. This high power supply rejection is maintained down to lower input voltage levels common to battery operated circuits.

The device is ideal for mobile phone and similar battery powered wireless applications. It provides up to 300 mA, from a 2.5V to 6V input, consuming less than 1 $\mu\text{A}$  in disable mode.

The LP3981 is available in VSSOP-8 package. For LP3981 in WSON-6 package, contact TI sales offices. Performance is specified for  $-40^\circ\text{C}$  to  $+125^\circ\text{C}$  temperature range. The device available in the following output voltages; 2.5V, 2.7V, 2.8V, 2.83V, 3.0V, 3.03V and 3.3V as standard. Other output options can be made available, please contact your local TI sales office.

### Typical Application Circuit

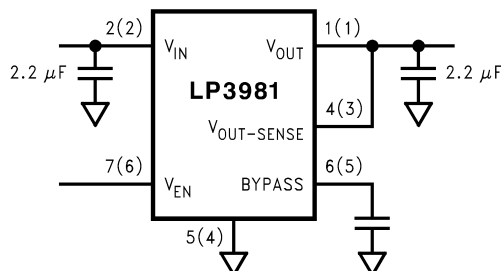

Note: Pin Numbers in parenthesis indicate WSON-6 package.



Please be aware that an important notice concerning availability, standard warranty, and use in critical applications of Texas Instruments semiconductor products and disclaimers thereto appears at the end of this data sheet.

All trademarks are the property of their respective owners.

**Block Diagram**

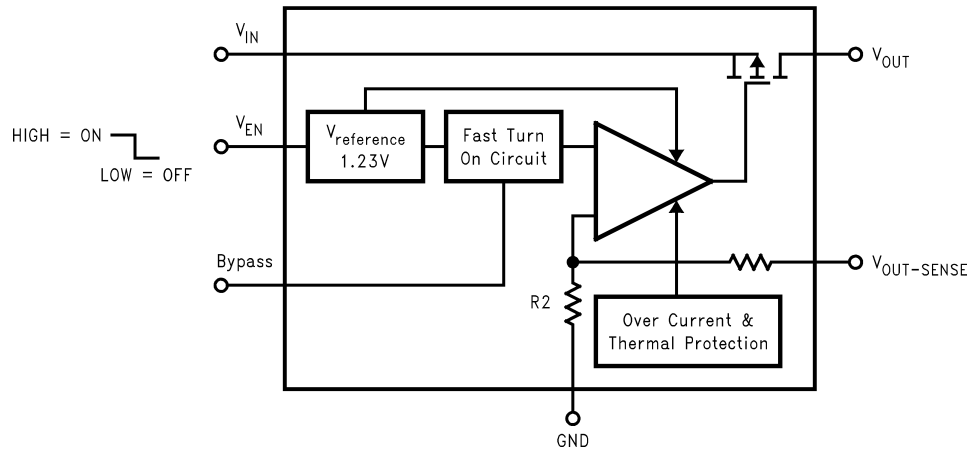

**PIN DESCRIPTIONS**

Name	VSSOP-8	WSON-6	Function
V <sub>EN</sub>	7	6	Enable Input Logic, Enable High.
GND	5	4	Common Ground. Connect to PAD.
V <sub>OUT</sub>	1	1	Output Voltage of the LDO.
V <sub>IN</sub>	2	2	Input Voltage of the LDO.
Bypass	6	5	Optional bypass capacitor for noise reduction.
V <sub>OUT-SENSE</sub>	4	3	Output. Voltage Sense Pin. Should be connected to V <sub>OUT</sub> for proper operation.
N.C.	3, 8		
GND		PAD	Common Ground. Connect to pin 4.

**Connection Diagrams**

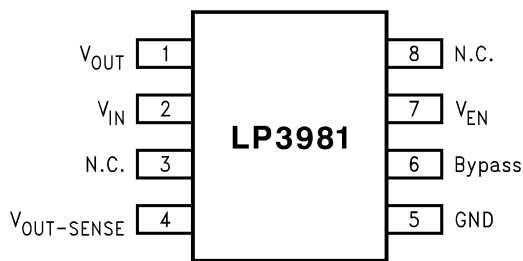

**Figure 1. Top View  
VSSOP-8 Package  
See Package Number DGK**

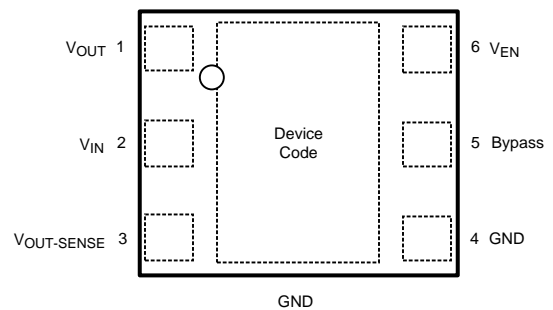

**Figure 2. Top View  
WSO-6 Package  
See Package Number NGC0006D**

**ORDERING INFORMATION<sup>(1)(2)</sup>**

<b>WS0N-6</b>				
<b>Output Voltage</b>	<b>Grade</b>	<b>LP3981 Supplied as 1000 Units Tape and Reel</b>	<b>LP3981 Supplied as 4500 Units Tape and Reel</b>	<b>Package Marking</b>
2.5V	STD	LP3981ILD-2.5	LP3981ILD-2.5	LO1UB
2.7V		LP3981ILD-2.7	LP3981ILD-2.7	LO1VB
2.8V		LP3981ILD-2.8	LP3981ILD-2.8	LO1ZB
2.83V		LP3981ILD-2.83	LP3981ILD-2.83	L01SB
3.0V		LP3981ILD-3.0	LP3981ILD-3.0	L017B
3.03V		LP3981ILD-3.03	LP3981ILD-3.03	LO1YB
3.3V		LP3981ILD-3.3	LP3981ILD-3.3	LO1XB
3.3V		LP3981ILD-3.3	LP3981ILD-3.3	LP3981ILD-3.3
<b>VSSOP-8 Package</b>				
<b>Output Voltage</b>	<b>Grade</b>	<b>LP3981 Supplied as 1000 Units Tape and Reel</b>	<b>LP3981 Supplied as 3500 Units Tape and Reel</b>	<b>Package Marking</b>
2.5V	STD	LP3981IMM-2.5	LP3981IMM-2.5	LFKB
2.7V		LP3981IMM-2.7	LP3981IMM-2.7	LFLB
2.8V		LP3981IMM-2.8	LP3981IMM-2.8	LFTB
2.83V		LP3981IMM-2.83	LP3981IMM-2.83	LDUB
3.0V		LP3981IMM-3.0	LP3981IMM-3.0	LF3B
3.03V		LP3981IMM-3.03	LP3981IMM-3.03	LFPB
3.3V		LP3981IMM-3.3	LP3981IMM-3.3	LFNB
3.3V		LP3981IMM-3.3	LP3981IMM-3.3	LP3981IMM-3.3

- (1) For the most current package and ordering information, see the Package Option Addendum at the end of this document, or see the TI web site at [www.ti.com](http://www.ti.com).
- (2) Package drawings, thermal data, and symbolization are available at [www.ti.com/packaging](http://www.ti.com/packaging).



These devices have limited built-in ESD protection. The leads should be shorted together or the device placed in conductive foam during storage or handling to prevent electrostatic damage to the MOS gates.

**Absolute Maximum Ratings**<sup>(1)(2)(3)</sup>

V <sub>IN</sub> , V <sub>EN</sub>	-0.3 to 6.5V
V <sub>OUT</sub> , V <sub>OUT-SENSE</sub>	-0.3 to V <sub>IN</sub> + 0.3, Max 6.5V
Junction Temperature	150°C
Storage Temperature	-65°C to +150°C
Lead Temp.	
Pad Temp.	
Power Dissipation <sup>(4)</sup> θ <sub>JA</sub> (VSSOP-8) θ <sub>JA</sub> (WSO-6)	210°C/W 50°C/W
Maximum Power Dissipation at 25°C VSSOP-8 WSO-6	595mW 2.5W
ESD Rating <sup>(5)</sup> Human Body Model Machine Model	2kV 200V

- (1) Stresses beyond those listed under absolute maximum ratings may cause permanent damage to the device. These are stress ratings only, and functional operation of the device at these or any other conditions beyond those indicated under recommended operating conditions is not implied. Exposure to absolute-maximum-rated conditions for extended periods may affect device reliability.
- (2) All voltages are with respect to the potential at the GND pin.
- (3) If Military/Aerospace specified devices are required, please contact the TI Sales Office/Distributors for availability and specifications.
- (4) The figures given for Absolute Maximum Power dissipation for the device are calculated using the following equations:
 
$$P_D = \frac{(T_{J(MAX)} - T_A)}{\theta_{JA}}$$
 where T<sub>J(MAX)</sub> is the maximum junction temperature, T<sub>A</sub> is the ambient temperature, and θ<sub>JA</sub> is the junction-to-ambient thermal resistance. E.g. for the WSO package θ<sub>JA</sub>=50°C/W, T<sub>J(MAX)</sub>=150°C and using T<sub>A</sub>=25°C the maximum power dissipation is found to be 2.5W. The derating factor (-1/θ<sub>JA</sub>) = -20mW/°C, thus below 25°C the power dissipation figure can be increased by 20 mW per degree, and similarly decreased by this factor for temperatures above 25°C
- (5) The human body model is 100pF discharged through 1.5kΩ resistor into each pin. The machine model is a 200 pF capacitor discharged directly into each pin.

**Operating Ratings**<sup>(1)(2)</sup>

V <sub>IN</sub>	2.7 to 6V
V <sub>EN</sub>	0 to V <sub>IN</sub>
Junction Temperature	-40°C to +125°C
Maximum Power Dissipation <sup>(3)</sup> VSSOP-8 WSO-6	476mW 2.0W

- (1) Stresses beyond those listed under absolute maximum ratings may cause permanent damage to the device. These are stress ratings only, and functional operation of the device at these or any other conditions beyond those indicated under recommended operating conditions is not implied. Exposure to absolute-maximum-rated conditions for extended periods may affect device reliability.
- (2) All voltages are with respect to the potential at the GND pin.
- (3) As for the Maximum Power dissipation, the maximum power in operation is dependant on the ambient temperature. This can be calculated in the same way using T<sub>J</sub>=125°C, giving 2W as the maximum power dissipation for the WSO package in operation. The same derating factor applies.

## Electrical Characteristics

Unless otherwise specified:  $V_{EN} = 1.2V$ ,  $V_{IN} = V_{OUT} + 0.5V$ ,  $C_{IN} = 2.2 \mu F$ ,  $C_{BP} = 0.033 \mu F$ ,  $I_{OUT} = 1mA$ ,  $C_{OUT} = 2.2 \mu F$ . Typical values and limits appearing in standard typeface are for  $T_J = 25^\circ C$ . Limits appearing in **boldface type** apply over the entire junction temperature range for operation,  $-40^\circ C$  to  $+125^\circ C$ .<sup>(1)(2)</sup>

Symbol	Parameter	Conditions	Typ	Limit		Units
				Min	Max	
$\Delta V_{OUT}$	Output Voltage Tolerance			-2 <b>-3</b>	2 <b>3</b>	% of $V_{OUT(nom)}$
	Line Regulation Error	$V_{IN} = V_{OUT} + 0.5V$ to $6.0V$ , $T_A < +85^\circ C$	0.005	-0.1	0.1	%/V
		$V_{IN} = V_{OUT} + 0.5V$ to $6.0V$ , $T_J \leq 125^\circ C$		<b>-0.2</b>	<b>0.2</b>	%/V
Load Regulation Error <sup>(3)</sup>	$I_{OUT} = 1mA$ to $300mA$	0.0003			<b>0.005</b>	%/mA
PSRR	Power Supply Rejection Ratio <sup>(4)</sup>	$V_{IN} = V_{OUT(nom)} + 1V$ , $f = 1kHz$ , $I_{OUT} = 50mA$ (Figure 4)	50			dB
		$V_{IN} = V_{OUT(nom)} + 1V$ , $f = 10kHz$ , $I_{OUT} = 50mA$ (Figure 4)	55			
$I_Q$	Quiescent Current	$V_{EN} = 1.2V$ , $I_{OUT} = 1mA$	70		<b>120</b>	$\mu A$
		$V_{EN} = 1.2V$ , $I_{OUT} = 1$ to $300mA$ , $V_{OUT} = 2.5V$ <sup>(5)</sup>	170		<b>210</b>	
		$V_{EN} = 0.4V$	0.003		<b>1.5</b>	
	Dropout Voltage <sup>(6)</sup>	$I_{OUT} = 1mA$	0.5		<b>5</b>	mV
		$I_{OUT} = 200mA$	88		<b>133</b>	
		$I_{OUT} = 300mA$	132		<b>200</b>	
$I_{SC}$	Short Circuit Current Limit	Output Grounded (Steady State)	600			mA
$e_n$	Output Noise Voltage	BW = 10 Hz to 100 kHz, $C_{BP} = 0.033\mu F$	35			$\mu V_{rms}$
TSD	Thermal Shutdown Temperature		160			$^\circ C$
	Thermal Shutdown Hysteresis		20			$^\circ C$
$I_{OUT(PK)}$	Peak Output Current	$V_{OUT} \geq V_{OUT(nom)} - 5\%$	455	300		
$I_{EN}$	Maximum Input Current at $V_{EN}$	$V_{EN} = 0$ and $V_{IN}$	0.001			$\mu A$
$V_{IL}$	Logic Low Input threshold	$V_{IN} = 2.7$ to $6.0V$			<b>0.4</b>	V
$V_{IH}$	Logic High Input threshold	$V_{IN} = 2.7$ to $6.0V$		<b>1.4</b>		V
$T_{ON}$	Turn-On Time <sup>(4)(7)</sup>	$C_{BYPASS} = 0.033 \mu F$	240		<b>350</b>	$\mu s$

- (1) Min and Max Limits are specified by design, test, or statistical analysis. Typical (Typ.) numbers are not verified, but do represent the most likely norm.
- (2) The target output voltage, which is labeled  $V_{OUT(nom)}$ , is the desired voltage option.
- (3) An increase in the load current results in a slight decrease in the output voltage and vice versa.
- (4) Specified by design. Not production tested.
- (5) For  $V_{OUT} > 2.5V$ , Increase  $I_{Q(MAX)}$  by  $2.5\mu A$  for every  $0.1V$  increase in  $V_{OUT(NOM)}$ . i.e.  $I_{Q(MAX)} = 210 + ((V_{OUT(NOM)} - 2.5) * 25)\mu A$
- (6) Dropout voltage is the input-to-output voltage difference at which the output voltage is  $100mV$  below its nominal value. This specification does not apply for input voltages below  $2.5V$ .
- (7) Turn-on time is time measured between the enable input just exceeding  $V_{IH}$  and the output voltage just reaching 95% of its nominal value.

**Electrical Characteristics Output Capacitor, Recommended Specification**

Symbol	Parameter	Conditions	Typ	Limit		Units
				Min	Max	
C <sub>OUT</sub>	Output Capacitor	Capacitance		2.2	22	μF
		ESR		5	500	mΩ

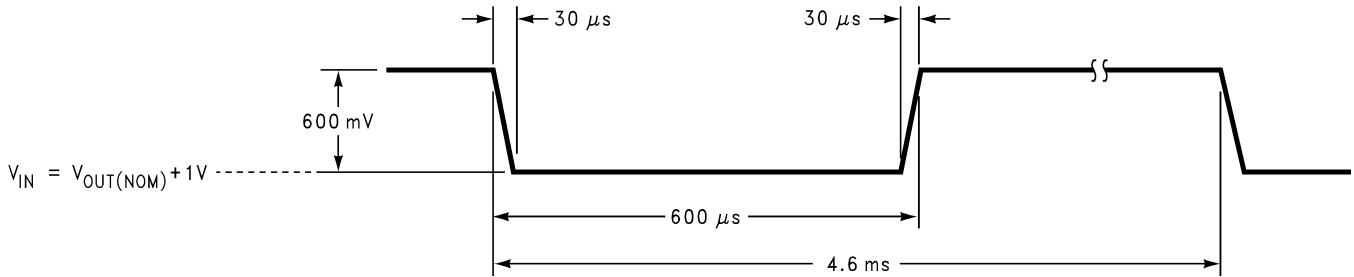

**Figure 3. Line Transient Response Input Perturbation**

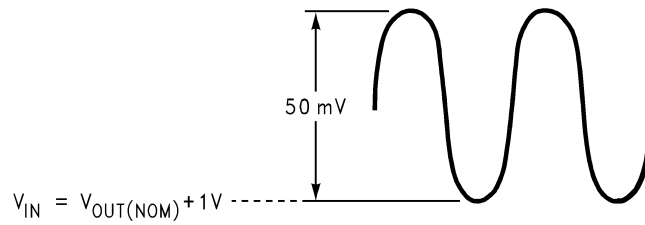

**Figure 4. PSRR Input Perturbation**

### Typical Performance Characteristics

Unless otherwise specified,  $C_{IN} = C_{OUT} = 2.2 \mu\text{F}$  Ceramic,  $C_{BP} = 0.033 \mu\text{F}$ ,  $V_{IN} = V_{OUT} + 0.5\text{V}$ ,  $T_A = 25^\circ\text{C}$ , Enable pin is tied to  $V_{IN}$ .

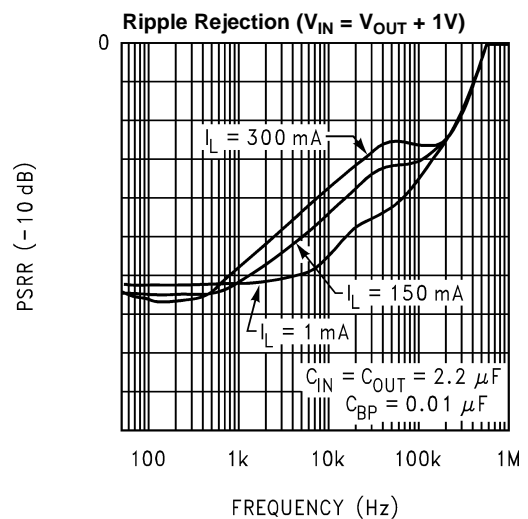
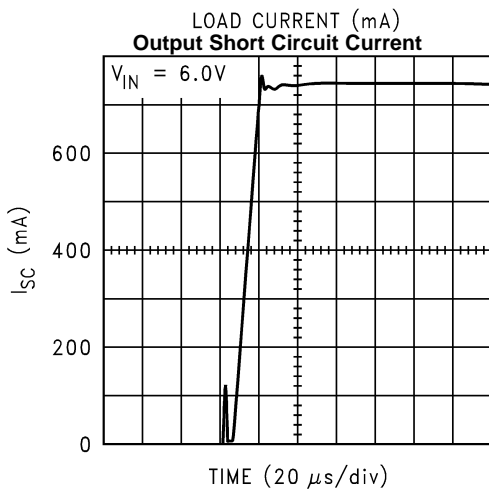
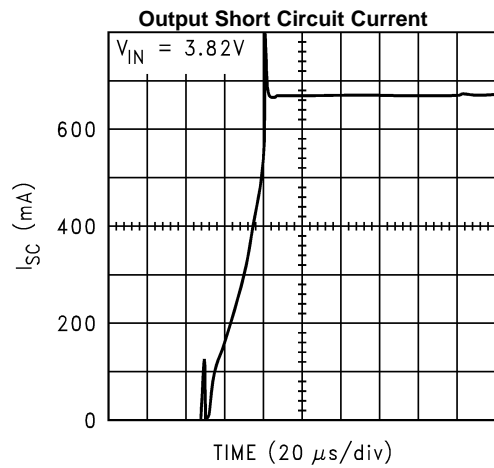
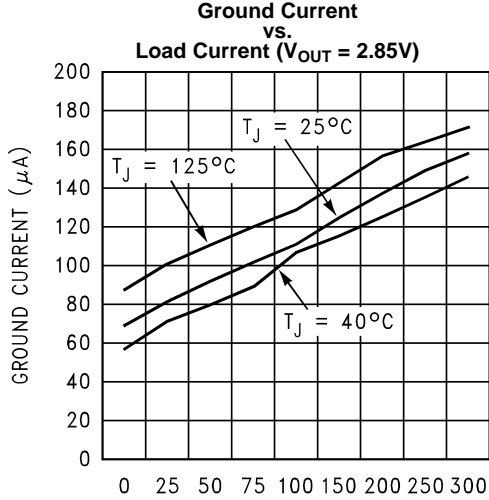
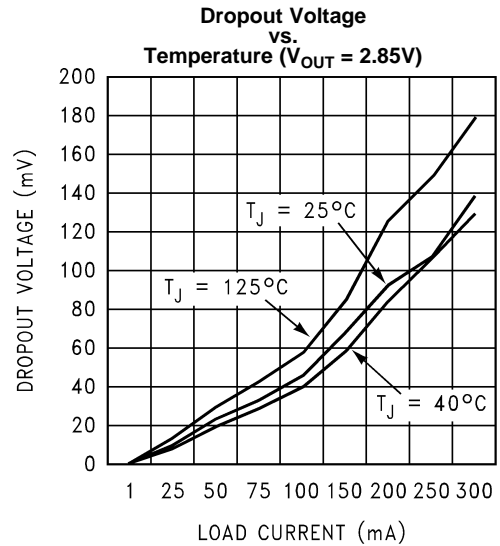
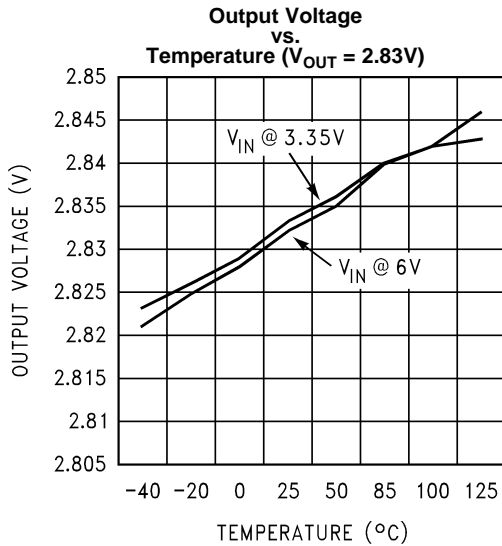

### Typical Performance Characteristics (continued)

Unless otherwise specified,  $C_{IN} = C_{OUT} = 2.2 \mu\text{F}$  Ceramic,  $C_{BP} = 0.033 \mu\text{F}$ ,  $V_{IN} = V_{OUT} + 0.5\text{V}$ ,  $T_A = 25^\circ\text{C}$ , Enable pin is tied to  $V_{IN}$ .

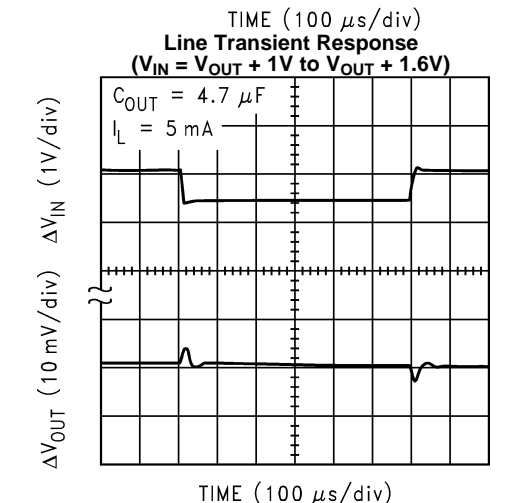
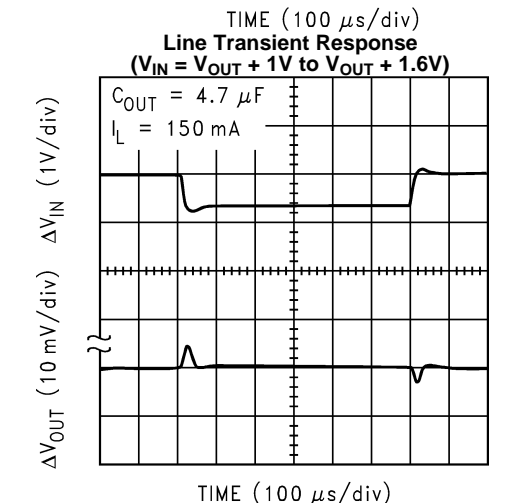
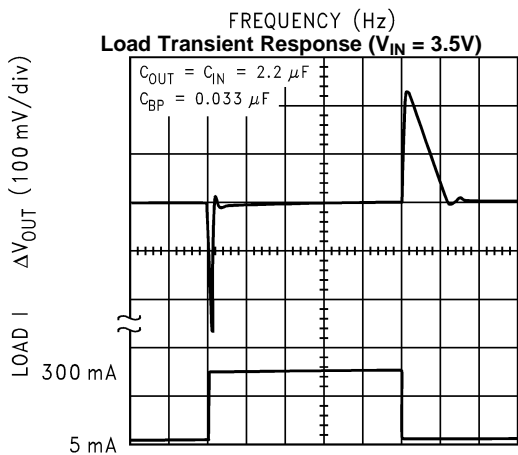
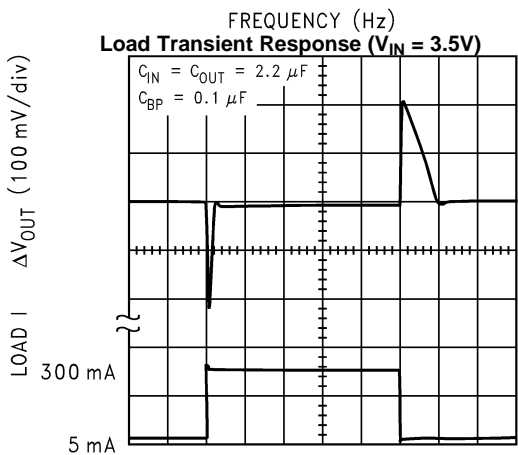
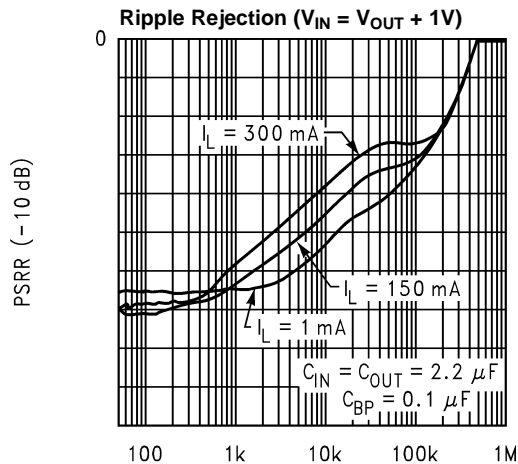
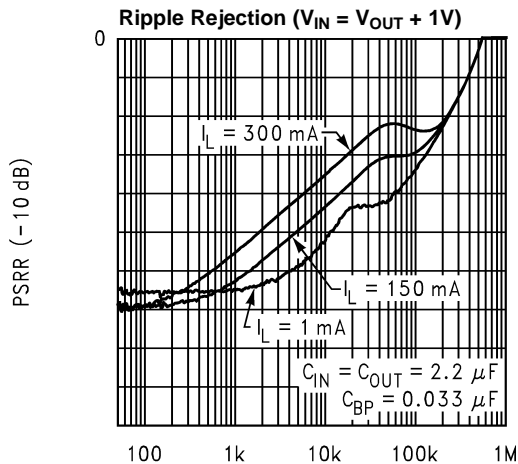



### Typical Performance Characteristics (continued)

Unless otherwise specified,  $C_{IN} = C_{OUT} = 2.2 \mu\text{F}$  Ceramic,  $C_{BP} = 0.033 \mu\text{F}$ ,  $V_{IN} = V_{OUT} + 0.5\text{V}$ ,  $T_A = 25^\circ\text{C}$ , Enable pin is tied to  $V_{IN}$ .

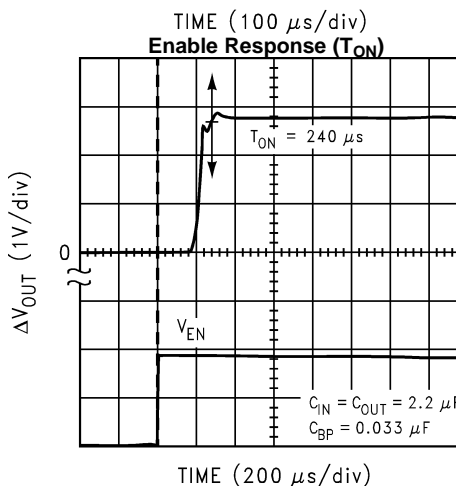
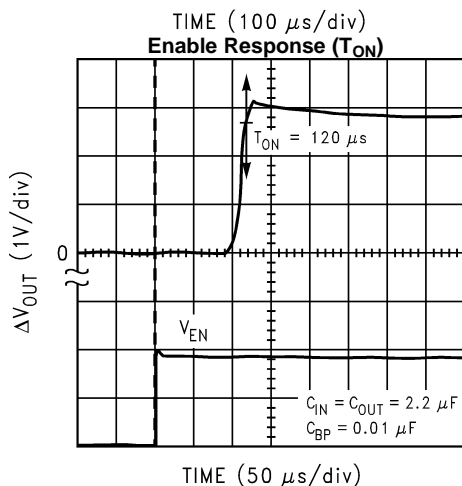
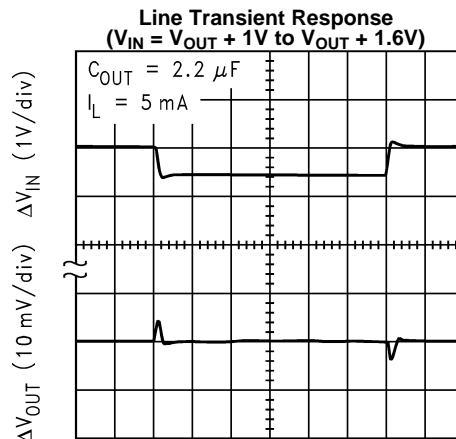
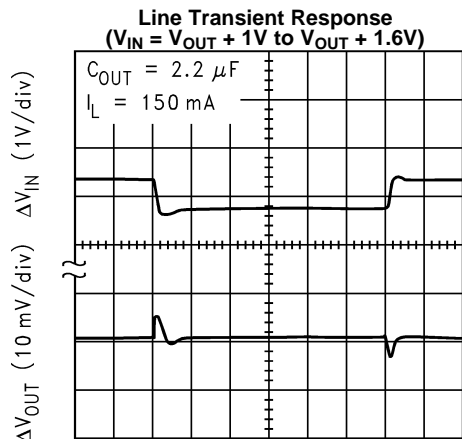

## APPLICATION HINTS

### POWER DISSIPATION AND DEVICE OPERATION

The permissible power dissipation for any package is a measure of the capability of the device to pass heat from the power source, the junctions of the IC, to the ultimate heat sink, the ambient environment. Thus, the power dissipation is dependant on the ambient temperature and the thermal resistance across the various interfaces between the die and ambient air.

As stated in the notes for [Absolute Maximum Ratings](#) and [Operating Ratings](#), the allowable power dissipation for the device in a given package can be calculated using the equation:

$$P_D = \frac{(T_{J(MAX)} - T_A)}{\theta_{JA}} \quad (1)$$

With a  $\theta_{JA} = 50^\circ\text{C/W}$ , the device in the WSON package returns a value of 2.0W with a maximum junction temperature of  $125^\circ\text{C}$  and an ambient temperature of  $25^\circ\text{C}$ . The device in a VSSOP package returns a figure of 0.476W, ( $\theta_{JA} = 210^\circ\text{C/W}$ ).

The actual power dissipation across the device can be represented by the following equation:

$$P_D = (V_{IN} - V_{OUT}) \times I_{OUT} \quad (2)$$

This establishes the relationship between the power dissipation allowed due to thermal considerations, the voltage drop across the device, and the continuous current capability of the device. The device can deliver 300mA but care must be taken when choosing the continuous current output for the device under the operating load conditions.

### EXTERNAL CAPACITORS

Like any low-dropout regulator, the LP3981 requires external capacitors for regulator stability. The LP3981 is specifically designed for portable applications requiring minimum board space and smallest components. These capacitors must be correctly selected for good performance.

### INPUT CAPACITOR

An input capacitance of  $\approx 2.2\mu\text{F}$  is required between the LP3981 input pin and ground (the amount of the capacitance may be increased without limit).

This capacitor must be located a distance of not more than 1cm from the input pin and returned to a clean analog ground. Any good quality ceramic, tantalum, or film capacitor may be used at the input.

**Important:** Tantalum capacitors can suffer catastrophic failures due to surge current when connected to a low-impedance source of power (like a battery or a very large capacitor). If a tantalum capacitor is used at the input, it must be specified by the manufacturer to have a surge current rating sufficient for the application.

There are no requirements for the ESR on the input capacitor, but tolerance and temperature coefficient must be considered when selecting the capacitor to ensure the capacitance will be  $\approx 2.2\mu\text{F}$  over the entire operating temperature range.

### OUTPUT CAPACITOR

The LP3981 is designed specifically to work with very small ceramic output capacitors. A ceramic capacitor (dielectric types Z5U, Y5V or X7R) in 2.2 to 22  $\mu\text{F}$  range with 5m $\Omega$  to 500m $\Omega$  ESR range is suitable in the LP3981 application circuit.

It may also be possible to use tantalum or film capacitors at the output, but these are not as attractive for reasons of size and cost (see [CAPACITOR CHARACTERISTICS](#)).

The output capacitor must meet the requirement for minimum amount of capacitance and also have an ESR (Equivalent Series Resistance) value which is within a stable range (5 m $\Omega$  to 500 m $\Omega$ ).

### NO-LOAD STABILITY

The LP3981 will remain stable and in regulation with no external load. This is specially important in CMOS RAM keep-alive applications.

## NOISE BYPASS CAPACITOR

Connecting a 0.033 $\mu$ F capacitor between the C<sub>BP</sub> pin and ground significantly reduces noise on the regulator output. This cap is connected directly to a high impedance node in the bad gap reference circuit. Any significant loading on this node will cause a change on the regulated output voltage. For this reason, DC leakage current through this pin must be kept as low as possible for best output voltage accuracy.

The types of capacitors best suited for the noise bypass capacitor are ceramic and film. High-quality ceramic capacitors with either NPO or COG dielectric typically have very low leakage. Polypropylene and polycarbonate film capacitors are available in small surface-mount packages and typically have extremely low leakage current.

Unlike many other LDO's, addition of a noise reduction capacitor does not effect the transient response of the device.

## CAPACITOR CHARACTERISTICS

The LP3981 is designed to work with ceramic capacitors on the output to take advantage of the benefits they offer: for capacitance values in the range of 1 $\mu$ F to 4.7 $\mu$ F range, ceramic capacitors are the smallest, least expensive and have the lowest ESR values (which makes them best for eliminating high frequency noise). The ESR of a typical 1 $\mu$ F ceramic capacitor is in the range of 20 m $\Omega$  to 40 m $\Omega$ , which easily meets the ESR requirement for stability by the LP3981.

The ceramic capacitor's capacitance can vary with temperature. Most large value ceramic capacitors ( $\approx$  2.2 $\mu$ F) are manufactured with Z5U or Y5V temperature characteristics, which results in the capacitance dropping by more than 50% as the temperature goes from 25°C to 85°C.

A better choice for temperature coefficient in a ceramic capacitor is X7R, which holds the capacitance within  $\pm$ 15%.

Tantalum capacitors are less desirable than ceramic for use as output capacitors because they are more expensive when comparing equivalent capacitance and voltage ratings in the 1 $\mu$ F to 4.7 $\mu$ F range.

Another important consideration is that tantalum capacitors have higher ESR values than equivalent size ceramics. This means that while it may be possible to find a tantalum capacitor with an ESR value within the stable range, it would have to be larger in capacitance (which means bigger and more costly ) than a ceramic capacitor with the same ESR value. It should also be noted that the ESR of a typical tantalum will increase about 2:1 as the temperature goes from 25°C down to -40°C, so some guard band must be allowed.

## ON/OFF INPUT OPERATION

The LP3981 is turned off by pulling the V<sub>EN</sub> pin low, and turned on by pulling it high. If this feature is not used, the V<sub>EN</sub> pin should be tied to V<sub>IN</sub> to keep the regulator output on at all time. To assure proper operation, the signal source used to drive the V<sub>EN</sub> input must be able to swing above and below the specified turn-on/off voltage thresholds listed in the [Electrical Characteristics](#) section under V<sub>IL</sub> and V<sub>IH</sub>.

## FAST ON-TIME



The LP3981 utilizes a speed up circuitry to ramp up the internal V<sub>REF</sub> voltage to its final value to achieve a fast output turn on time.

## REVISION HISTORY

Changes from Revision F (May 2013) to Revision G	Page
• Changed layout of National Data Sheet to TI format .....	<a href="#">11</a>

**PACKAGING INFORMATION**

Orderable Device	Status (1)	Package Type	Package Drawing	Pins	Package Qty	Eco Plan (2)	Lead/Ball Finish (6)	MSL Peak Temp (3)	Op Temp (°C)	Device Marking (4/5)	Samples
LP3981ILD-2.5	NRND	WSOP	NGC	6	1000	TBD	Call TI	Call TI	-40 to 125	LO1UB	
LP3981ILD-2.5/NOPB	ACTIVE	WSOP	NGC	6	1000	Green (RoHS & no Sb/Br)	CU SN	Level-3-260C-168 HR	-40 to 125	LO1UB	<a href="#">Samples</a>
LP3981ILD-2.8/NOPB	ACTIVE	WSOP	NGC	6	1000	Green (RoHS & no Sb/Br)	CU SN	Level-3-260C-168 HR	-40 to 125	L01ZB	<a href="#">Samples</a>
LP3981ILD-3.0/NOPB	ACTIVE	WSOP	NGC	6	1000	Green (RoHS & no Sb/Br)	CU SN   Call TI	Level-3-260C-168 HR		L017B	<a href="#">Samples</a>
LP3981ILD-3.3/NOPB	ACTIVE	WSOP	NGC	6	1000	Green (RoHS & no Sb/Br)	CU SN	Level-3-260C-168 HR	-40 to 125	LO1XB	<a href="#">Samples</a>
LP3981ILD-2.5/NOPB	ACTIVE	WSOP	NGC	6	4500	Green (RoHS & no Sb/Br)	CU SN	Level-3-260C-168 HR	-40 to 125	LO1UB	<a href="#">Samples</a>
LP3981ILD-2.7/NOPB	ACTIVE	WSOP	NGC	6	4500	Green (RoHS & no Sb/Br)	CU SN	Level-3-260C-168 HR	-40 to 125	LO1VB	<a href="#">Samples</a>
LP3981ILD-2.8/NOPB	ACTIVE	WSOP	NGC	6	4500	Green (RoHS & no Sb/Br)	CU SN	Level-3-260C-168 HR	-40 to 125	L01ZB	<a href="#">Samples</a>
LP3981ILD-2.83/NOPB	ACTIVE	WSOP	NGC	6	4500	Green (RoHS & no Sb/Br)	CU SN	Level-3-260C-168 HR	-40 to 125	LO1SB	<a href="#">Samples</a>
LP3981ILD-3.03/NOPB	ACTIVE	WSOP	NGC	6	4500	Green (RoHS & no Sb/Br)	CU SN	Level-3-260C-168 HR	-40 to 125	LO1YB	<a href="#">Samples</a>
LP3981IMM-2.5	NRND	VSSOP	DGK	8	1000	TBD	Call TI	Call TI	-40 to 125	LFKB	
LP3981IMM-2.5/NOPB	ACTIVE	VSSOP	DGK	8	1000	Green (RoHS & no Sb/Br)	CU SN	Level-1-260C-UNLIM	-40 to 125	LFKB	<a href="#">Samples</a>
LP3981IMM-2.7/NOPB	ACTIVE	VSSOP	DGK	8	1000	Green (RoHS & no Sb/Br)	CU SN	Level-1-260C-UNLIM	-40 to 125	LFLB	<a href="#">Samples</a>
LP3981IMM-2.8/NOPB	ACTIVE	VSSOP	DGK	8	1000	Green (RoHS & no Sb/Br)	CU SN	Level-1-260C-UNLIM	-40 to 125	LFTB	<a href="#">Samples</a>
LP3981IMM-3.0/NOPB	ACTIVE	VSSOP	DGK	8	1000	Green (RoHS & no Sb/Br)	CU SN	Level-1-260C-UNLIM		LF3B	<a href="#">Samples</a>
LP3981IMM-3.03	NRND	VSSOP	DGK	8	1000	TBD	Call TI	Call TI	-40 to 125	LFPB	
LP3981IMM-3.03/NOPB	ACTIVE	VSSOP	DGK	8	1000	Green (RoHS & no Sb/Br)	CU SN	Level-1-260C-UNLIM	-40 to 125	LFPB	<a href="#">Samples</a>
LP3981IMM-3.3	NRND	VSSOP	DGK	8	1000	TBD	Call TI	Call TI	-40 to 125	LFNB	
LP3981IMM-3.3/NOPB	ACTIVE	VSSOP	DGK	8	1000	Green (RoHS & no Sb/Br)	CU SN	Level-1-260C-UNLIM	-40 to 125	LFNB	<a href="#">Samples</a>

Orderable Device	Status (1)	Package Type	Package Drawing	Pins	Package Qty	Eco Plan (2)	Lead/Ball Finish (6)	MSL Peak Temp (3)	Op Temp (°C)	Device Marking (4/5)	Samples
LP3981IMMX-2.5/NOPB	ACTIVE	VSSOP	DGK	8	3500	Green (RoHS & no Sb/Br)	CU SN	Level-1-260C-UNLIM	-40 to 125	LFKB	
LP3981IMMX-3.3/NOPB	ACTIVE	VSSOP	DGK	8	3500	Green (RoHS & no Sb/Br)	CU SN	Level-1-260C-UNLIM	-40 to 125	LFNB	

(1) The marketing status values are defined as follows:

**ACTIVE:** Product device recommended for new designs.

**LIFEBUY:** TI has announced that the device will be discontinued, and a lifetime-buy period is in effect.

**NRND:** Not recommended for new designs. Device is in production to support existing customers, but TI does not recommend using this part in a new design.

**PREVIEW:** Device has been announced but is not in production. Samples may or may not be available.

**OBSELETE:** TI has discontinued the production of the device.

(2) Eco Plan - The planned eco-friendly classification: Pb-Free (RoHS), Pb-Free (RoHS Exempt), or Green (RoHS & no Sb/Br) - please check <http://www.ti.com/productcontent> for the latest availability information and additional product content details.

**TBD:** The Pb-Free/Green conversion plan has not been defined.

**Pb-Free (RoHS):** TI's terms "Lead-Free" or "Pb-Free" mean semiconductor products that are compatible with the current RoHS requirements for all 6 substances, including the requirement that lead not exceed 0.1% by weight in homogeneous materials. Where designed to be soldered at high temperatures, TI Pb-Free products are suitable for use in specified lead-free processes.

**Pb-Free (RoHS Exempt):** This component has a RoHS exemption for either 1) lead-based flip-chip solder bumps used between the die and package, or 2) lead-based die adhesive used between the die and leadframe. The component is otherwise considered Pb-Free (RoHS compatible) as defined above.

**Green (RoHS & no Sb/Br):** TI defines "Green" to mean Pb-Free (RoHS compatible), and free of Bromine (Br) and Antimony (Sb) based flame retardants (Br or Sb do not exceed 0.1% by weight in homogeneous material)

(3) MSL, Peak Temp. - The Moisture Sensitivity Level rating according to the JEDEC industry standard classifications, and peak solder temperature.

(4) There may be additional marking, which relates to the logo, the lot trace code information, or the environmental category on the device.

(5) Multiple Device Markings will be inside parentheses. Only one Device Marking contained in parentheses and separated by a "~" will appear on a device. If a line is indented then it is a continuation of the previous line and the two combined represent the entire Device Marking for that device.

(6) Lead/Ball Finish - Orderable Devices may have multiple material finish options. Finish options are separated by a vertical ruled line. Lead/Ball Finish values may wrap to two lines if the finish value exceeds the maximum column width.

**Important Information and Disclaimer:** The information provided on this page represents TI's knowledge and belief as of the date that it is provided. TI bases its knowledge and belief on information provided by third parties, and makes no representation or warranty as to the accuracy of such information. Efforts are underway to better integrate information from third parties. TI has taken and continues to take reasonable steps to provide representative and accurate information but may not have conducted destructive testing or chemical analysis on incoming materials and chemicals. TI and TI suppliers consider certain information to be proprietary, and thus CAS numbers and other limited information may not be available for release.

In no event shall TI's liability arising out of such information exceed the total purchase price of the TI part(s) at issue in this document sold by TI to Customer on an annual basis.



## TAPE AND REEL INFORMATION

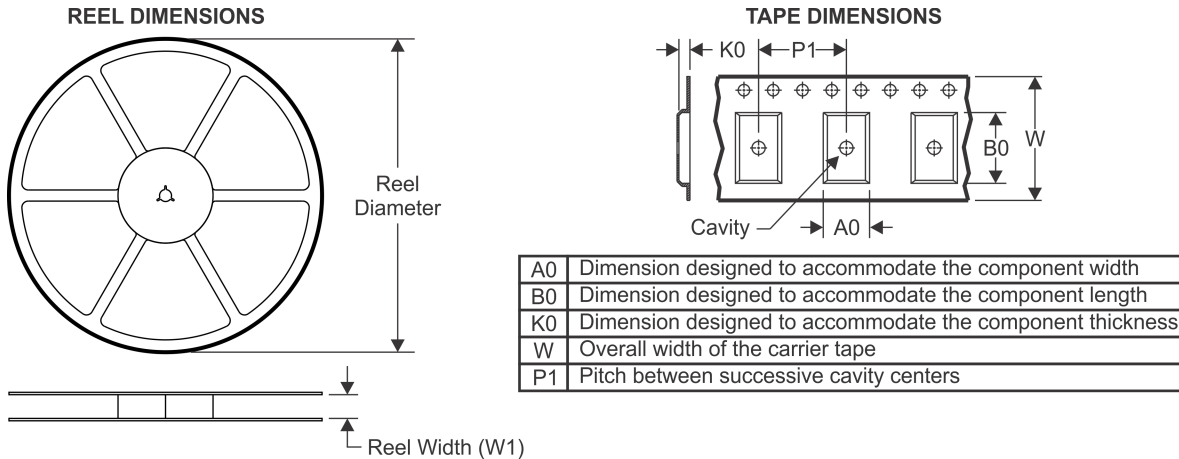

### QUADRANT ASSIGNMENTS FOR PIN 1 ORIENTATION IN TAPE



\*All dimensions are nominal

Device	Package Type	Package Drawing	Pins	SPQ	Reel Diameter (mm)	Reel Width W1 (mm)	A0 (mm)	B0 (mm)	K0 (mm)	P1 (mm)	W (mm)	Pin1 Quadrant
LP3981ILD-2.5	WSON	NGC	6	1000	178.0	12.4	4.3	3.3	1.0	8.0	12.0	Q1
LP3981ILD-2.5/NOPB	WSON	NGC	6	1000	178.0	12.4	4.3	3.3	1.0	8.0	12.0	Q1
LP3981ILD-2.8/NOPB	WSON	NGC	6	1000	178.0	12.4	4.3	3.3	1.0	8.0	12.0	Q1
LP3981ILD-3.0/NOPB	WSON	NGC	6	1000	178.0	12.4	4.3	3.3	1.0	8.0	12.0	Q1
LP3981ILD-3.3/NOPB	WSON	NGC	6	1000	178.0	12.4	4.3	3.3	1.0	8.0	12.0	Q1
LP3981ILD-2.5/NOPB	WSON	NGC	6	4500	330.0	12.4	4.3	3.3	1.0	8.0	12.0	Q1
LP3981ILD-2.7/NOPB	WSON	NGC	6	4500	330.0	12.4	4.3	3.3	1.0	8.0	12.0	Q1
LP3981ILD-2.8/NOPB	WSON	NGC	6	4500	330.0	12.4	4.3	3.3	1.0	8.0	12.0	Q1
LP3981ILD-2.83/NOPB	WSON	NGC	6	4500	330.0	12.4	4.3	3.3	1.0	8.0	12.0	Q1
LP3981ILD-3.03/NOPB	WSON	NGC	6	4500	330.0	12.4	4.3	3.3	1.0	8.0	12.0	Q1
LP3981IMM-2.5	VSSOP	DGK	8	1000	178.0	12.4	5.3	3.4	1.4	8.0	12.0	Q1
LP3981IMM-2.5/NOPB	VSSOP	DGK	8	1000	178.0	12.4	5.3	3.4	1.4	8.0	12.0	Q1
LP3981IMM-2.7/NOPB	VSSOP	DGK	8	1000	178.0	12.4	5.3	3.4	1.4	8.0	12.0	Q1
LP3981IMM-2.8/NOPB	VSSOP	DGK	8	1000	178.0	12.4	5.3	3.4	1.4	8.0	12.0	Q1
LP3981IMM-3.0/NOPB	VSSOP	DGK	8	1000	178.0	12.4	5.3	3.4	1.4	8.0	12.0	Q1
LP3981IMM-3.03	VSSOP	DGK	8	1000	178.0	12.4	5.3	3.4	1.4	8.0	12.0	Q1
LP3981IMM-3.03/NOPB	VSSOP	DGK	8	1000	178.0	12.4	5.3	3.4	1.4	8.0	12.0	Q1
LP3981IMM-3.3	VSSOP	DGK	8	1000	178.0	12.4	5.3	3.4	1.4	8.0	12.0	Q1

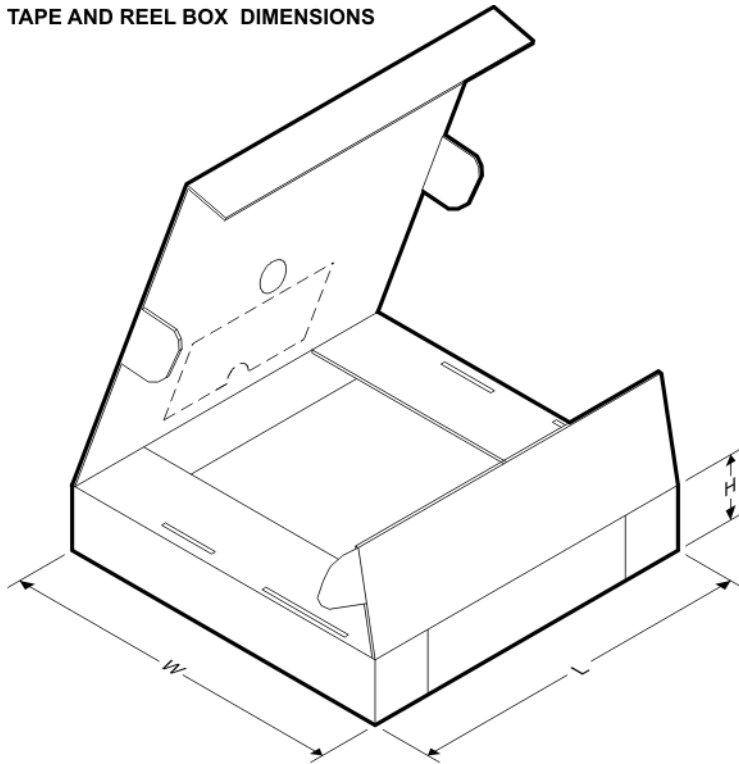

Device	Package Type	Package Drawing	Pins	SPQ	Reel Diameter (mm)	Reel Width W1 (mm)	A0 (mm)	B0 (mm)	K0 (mm)	P1 (mm)	W (mm)	Pin1 Quadrant
LP3981IMM-3.3/NOPB	VSSOP	DGK	8	1000	178.0	12.4	5.3	3.4	1.4	8.0	12.0	Q1
LP3981IMMX-2.5/NOPB	VSSOP	DGK	8	3500	330.0	12.4	5.3	3.4	1.4	8.0	12.0	Q1
LP3981IMMX-3.3/NOPB	VSSOP	DGK	8	3500	330.0	12.4	5.3	3.4	1.4	8.0	12.0	Q1

**TAPE AND REEL BOX DIMENSIONS**

\*All dimensions are nominal

Device	Package Type	Package Drawing	Pins	SPQ	Length (mm)	Width (mm)	Height (mm)
LP3981ILD-2.5	WSON	NGC	6	1000	210.0	185.0	35.0
LP3981ILD-2.5/NOPB	WSON	NGC	6	1000	213.0	191.0	55.0
LP3981ILD-2.8/NOPB	WSON	NGC	6	1000	213.0	191.0	55.0
LP3981ILD-3.0/NOPB	WSON	NGC	6	1000	213.0	191.0	55.0
LP3981ILD-3.3/NOPB	WSON	NGC	6	1000	213.0	191.0	55.0
LP3981ILD-2.5/NOPB	WSON	NGC	6	4500	367.0	367.0	35.0
LP3981ILD-2.7/NOPB	WSON	NGC	6	4500	367.0	367.0	35.0
LP3981ILD-2.8/NOPB	WSON	NGC	6	4500	367.0	367.0	35.0
LP3981ILD-2.83/NOPB	WSON	NGC	6	4500	367.0	367.0	35.0
LP3981ILD-3.03/NOPB	WSON	NGC	6	4500	367.0	367.0	35.0
LP3981IMM-2.5	VSSOP	DGK	8	1000	210.0	185.0	35.0
LP3981IMM-2.5/NOPB	VSSOP	DGK	8	1000	210.0	185.0	35.0
LP3981IMM-2.7/NOPB	VSSOP	DGK	8	1000	210.0	185.0	35.0
LP3981IMM-2.8/NOPB	VSSOP	DGK	8	1000	210.0	185.0	35.0

---

Device	Package Type	Package Drawing	Pins	SPQ	Length (mm)	Width (mm)	Height (mm)
LP3981IMM-3.0/NOPB	VSSOP	DGK	8	1000	210.0	185.0	35.0
LP3981IMM-3.03	VSSOP	DGK	8	1000	210.0	185.0	35.0
LP3981IMM-3.03/NOPB	VSSOP	DGK	8	1000	210.0	185.0	35.0
LP3981IMM-3.3	VSSOP	DGK	8	1000	210.0	185.0	35.0
LP3981IMM-3.3/NOPB	VSSOP	DGK	8	1000	210.0	185.0	35.0
LP3981IMMX-2.5/NOPB	VSSOP	DGK	8	3500	367.0	367.0	35.0
LP3981IMMX-3.3/NOPB	VSSOP	DGK	8	3500	367.0	367.0	35.0

DGK (S-PDSO-G8)

PLASTIC SMALL-OUTLINE PACKAGE

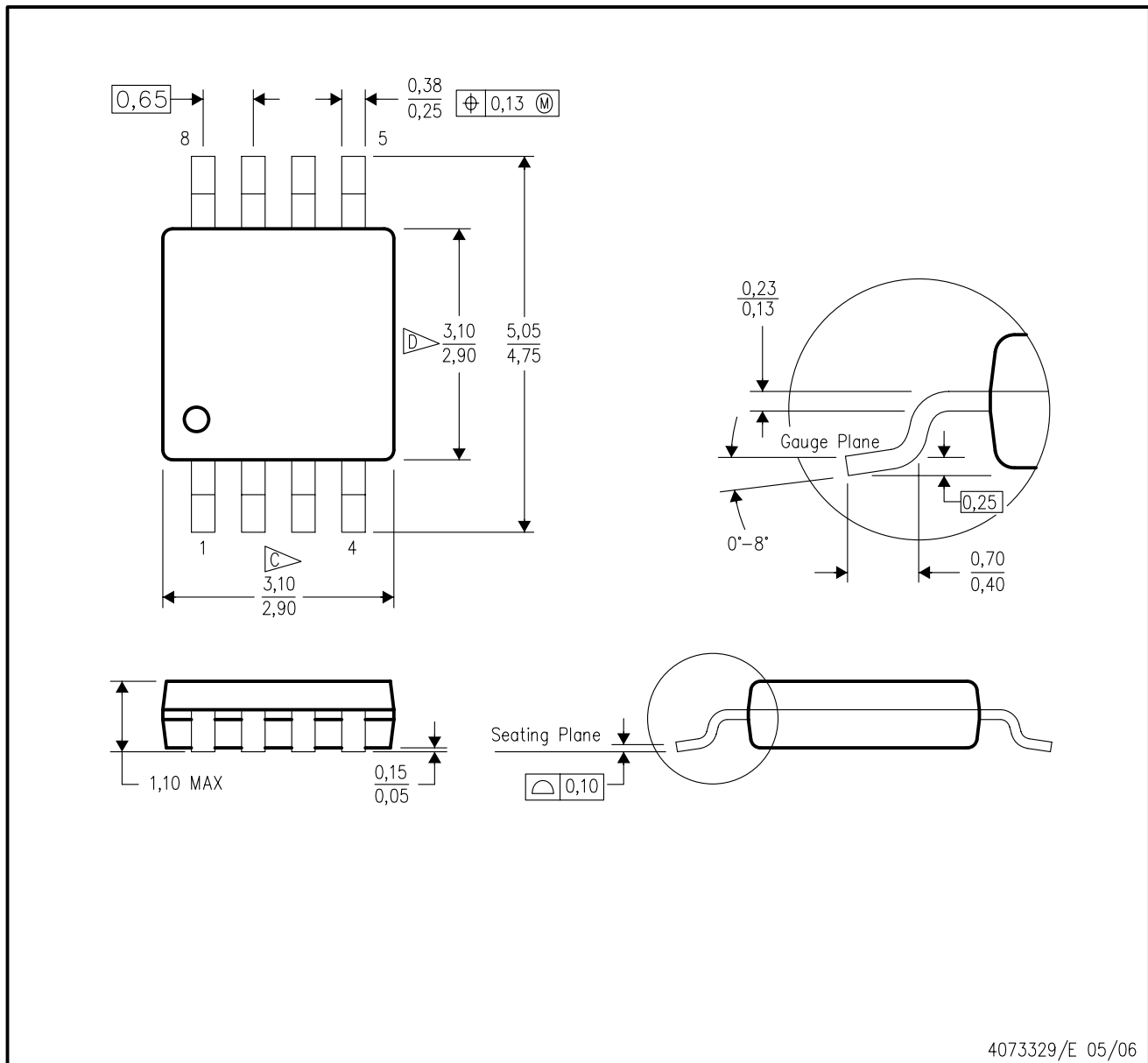

- NOTES:
- A. All linear dimensions are in millimeters.
  - B. This drawing is subject to change without notice.
  - C. Body length does not include mold flash, protrusions, or gate burrs. Mold flash, protrusions, or gate burrs shall not exceed 0.15 per end.
  - D. Body width does not include interlead flash. Interlead flash shall not exceed 0.50 per side.
  - E. Falls within JEDEC MO-187 variation AA, except interlead flash.

NGC0006D

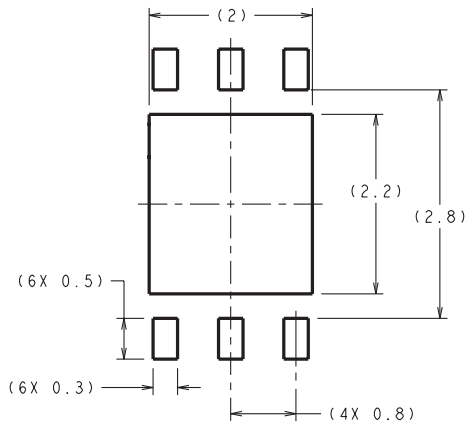

**RECOMMENDED LAND PATTERN**  
1:1 RATIO WITH PKG SOLDER PADS

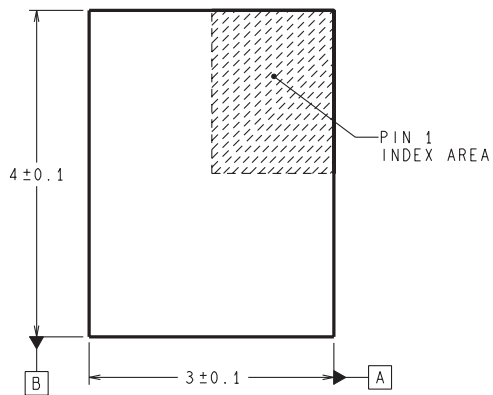

DIMENSIONS ARE IN MILLIMETERS

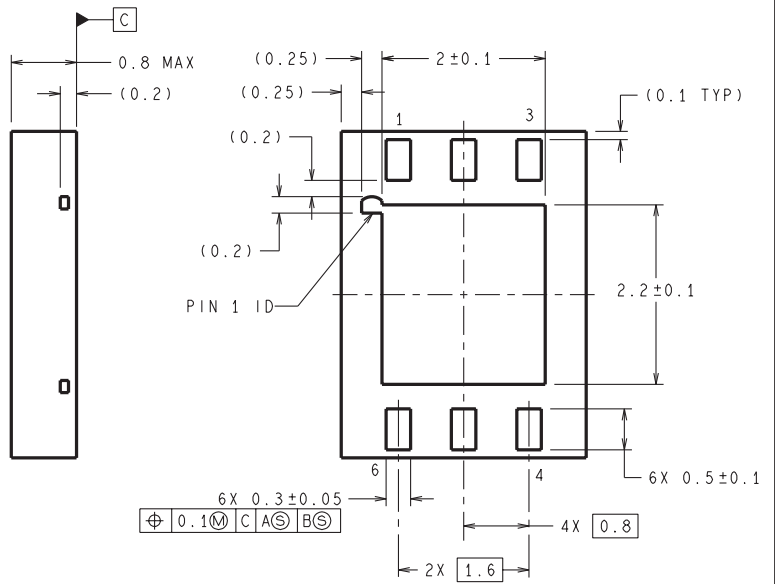

LDC06D (Rev B)

## IMPORTANT NOTICE

Texas Instruments Incorporated and its subsidiaries (TI) reserve the right to make corrections, enhancements, improvements and other changes to its semiconductor products and services per JESD46, latest issue, and to discontinue any product or service per JESD48, latest issue. Buyers should obtain the latest relevant information before placing orders and should verify that such information is current and complete. All semiconductor products (also referred to herein as "components") are sold subject to TI's terms and conditions of sale supplied at the time of order acknowledgment.

TI warrants performance of its components to the specifications applicable at the time of sale, in accordance with the warranty in TI's terms and conditions of sale of semiconductor products. Testing and other quality control techniques are used to the extent TI deems necessary to support this warranty. Except where mandated by applicable law, testing of all parameters of each component is not necessarily performed.

TI assumes no liability for applications assistance or the design of Buyers' products. Buyers are responsible for their products and applications using TI components. To minimize the risks associated with Buyers' products and applications, Buyers should provide adequate design and operating safeguards.

TI does not warrant or represent that any license, either express or implied, is granted under any patent right, copyright, mask work right, or other intellectual property right relating to any combination, machine, or process in which TI components or services are used. Information published by TI regarding third-party products or services does not constitute a license to use such products or services or a warranty or endorsement thereof. Use of such information may require a license from a third party under the patents or other intellectual property of the third party, or a license from TI under the patents or other intellectual property of TI.

Reproduction of significant portions of TI information in TI data books or data sheets is permissible only if reproduction is without alteration and is accompanied by all associated warranties, conditions, limitations, and notices. TI is not responsible or liable for such altered documentation. Information of third parties may be subject to additional restrictions.

Resale of TI components or services with statements different from or beyond the parameters stated by TI for that component or service voids all express and any implied warranties for the associated TI component or service and is an unfair and deceptive business practice. TI is not responsible or liable for any such statements.

Buyer acknowledges and agrees that it is solely responsible for compliance with all legal, regulatory and safety-related requirements concerning its products, and any use of TI components in its applications, notwithstanding any applications-related information or support that may be provided by TI. Buyer represents and agrees that it has all the necessary expertise to create and implement safeguards which anticipate dangerous consequences of failures, monitor failures and their consequences, lessen the likelihood of failures that might cause harm and take appropriate remedial actions. Buyer will fully indemnify TI and its representatives against any damages arising out of the use of any TI components in safety-critical applications.

In some cases, TI components may be promoted specifically to facilitate safety-related applications. With such components, TI's goal is to help enable customers to design and create their own end-product solutions that meet applicable functional safety standards and requirements. Nonetheless, such components are subject to these terms.

No TI components are authorized for use in FDA Class III (or similar life-critical medical equipment) unless authorized officers of the parties have executed a special agreement specifically governing such use.

Only those TI components which TI has specifically designated as military grade or "enhanced plastic" are designed and intended for use in military/aerospace applications or environments. Buyer acknowledges and agrees that any military or aerospace use of TI components which have **not** been so designated is solely at the Buyer's risk, and that Buyer is solely responsible for compliance with all legal and regulatory requirements in connection with such use.

TI has specifically designated certain components as meeting ISO/TS16949 requirements, mainly for automotive use. In any case of use of non-designated products, TI will not be responsible for any failure to meet ISO/TS16949.

### Products

Audio	<a href="http://www.ti.com/audio">www.ti.com/audio</a>
Amplifiers	<a href="http://amplifier.ti.com">amplifier.ti.com</a>
Data Converters	<a href="http://dataconverter.ti.com">dataconverter.ti.com</a>
DLP® Products	<a href="http://www.dlp.com">www.dlp.com</a>
DSP	<a href="http://dsp.ti.com">dsp.ti.com</a>
Clocks and Timers	<a href="http://www.ti.com/clocks">www.ti.com/clocks</a>
Interface	<a href="http://interface.ti.com">interface.ti.com</a>
Logic	<a href="http://logic.ti.com">logic.ti.com</a>
Power Mgmt	<a href="http://power.ti.com">power.ti.com</a>
Microcontrollers	<a href="http://microcontroller.ti.com">microcontroller.ti.com</a>
RFID	<a href="http://www.ti-rfid.com">www.ti-rfid.com</a>
OMAP Applications Processors	<a href="http://www.ti.com/omap">www.ti.com/omap</a>
Wireless Connectivity	<a href="http://www.ti.com/wirelessconnectivity">www.ti.com/wirelessconnectivity</a>

### Applications

Automotive and Transportation	<a href="http://www.ti.com/automotive">www.ti.com/automotive</a>
Communications and Telecom	<a href="http://www.ti.com/communications">www.ti.com/communications</a>
Computers and Peripherals	<a href="http://www.ti.com/computers">www.ti.com/computers</a>
Consumer Electronics	<a href="http://www.ti.com/consumer-apps">www.ti.com/consumer-apps</a>
Energy and Lighting	<a href="http://www.ti.com/energy">www.ti.com/energy</a>
Industrial	<a href="http://www.ti.com/industrial">www.ti.com/industrial</a>
Medical	<a href="http://www.ti.com/medical">www.ti.com/medical</a>
Security	<a href="http://www.ti.com/security">www.ti.com/security</a>
Space, Avionics and Defense	<a href="http://www.ti.com/space-avionics-defense">www.ti.com/space-avionics-defense</a>
Video and Imaging	<a href="http://www.ti.com/video">www.ti.com/video</a>

### TI E2E Community

[e2e.ti.com](http://e2e.ti.com)