



Size:
1.00 x 1.00 x 0.39 inches
(25.4 x 25.4 x 9.9 mm)

Options

- Negative Logic Remote ON/OFF
- Without Trim pin
- Without CTRL Pin
- Heatsink

FEATURES

- High Efficiency up to 92%
- Remote ON/OFF Control
- 4:1 Wide Input Voltage Ranges
- Six-Sided Continuous Shielding
- Ultra Low Quiescent Current
- No Minimum Load Requirements
- Single and Dual Outputs
- 30 Watts Maximum Output Power
- 1600VDC I/O Isolation
- Short Circuit, Over Voltage, Over Load, & Over Temp. Protection
- Wide Operating Temperature Range: -40°C to +100°C
- Compliant to RoHS & Reach
- UL60950-1, EN60950-1, & IEC60950-1 Safety Approvals
- Optional Heatsink Available (Suffix "HC")

DESCRIPTION

The JFCW30 series of DC/DC power converters provides 30 Watts of output power in an industry standard 1.00" x 1.00" x 0.39" package and footprint. This series has single and dual output models with 4:1 wide input voltage ranges of 9-36VDC and 18-75VDC. Some features include high efficiency up to 92%, 1600VDC I/O isolation, six-sided shielding, and remote ON/OFF control. These converters are also protected against short circuit, over load, over voltage, and over temperature conditions. All models are RoHS compliant and have UL60950-1, EN60950-1, and IEC60950-1 safety approvals. This series is best suited for use in wireless networks, industry control systems, telecom/datacom, and semiconductor equipment.

MODEL SELECTION TABLE

SINGLE OUTPUT MODELS

Model Number	Input Voltage Range	Output Voltage	Output Current		Output Ripple & Noise	No Load Input Current	Output Power	Efficiency	Maximum Capacitive Load
			Min Load	Max Load					
JFCW24S33-30	24 VDC (9 - 36 VDC)	3.3 VDC	0mA	7A	75mVp-p	10mA	23.1W	88%	10000µF
JFCW24S05-30		5 VDC	0mA	6A	75mVp-p	10mA	30W	89%	7200µF
JFCW24S12-30		12 VDC	0mA	2.5A	75mVp-p	10mA	30W	89%	1200µF
JFCW24S15-30		15 VDC	0mA	2A	75mVp-p	10mA	30W	89%	1000µF
JFCW24S24-30		24 VDC	0mA	1.25A	75mVp-p	10mA	30W	90%	375µF
JFCW48S33-30	48 VDC (18 - 75 VDC)	3.3 VDC	0mA	7A	75mVp-p	10mA	23.1W	88%	10000µF
JFCW48S05-30		5 VDC	0mA	6A	75mVp-p	10mA	30W	90%	7200µF
JFCW48S12-30		12 VDC	0mA	2.5A	75mVp-p	8mA	30W	90%	1200µF
JFCW48S15-30		15 VDC	0mA	2A	75mVp-p	8mA	30W	91%	1000µF
JFCW48S24-30		24 VDC	0mA	1.25A	75mVp-p	8mA	30W	92%	375µF

DUAL OUTPUT MODELS

Model Number	Input Voltage Range	Output Voltage	Output Current		Output Ripple & Noise	No Load Input Current	Output Power	Efficiency	Maximum Capacitive Load
			Min Load	Max Load					
JFCW24D12-30	24 VDC (9 - 36 VDC)	±12 VDC	0mA	±1.25A	60mVp-p	10mA	30W	89%	±750µF
JFCW24D15-30		±15 VDC	0mA	±1.0A	60mVp-p	10mA	30W	91%	±500µF
JFCW24D24-30		±24 VDC	0mA	±0.625A	75mVp-p	12mA	30W	91%	±180µF
JFCW48D12-30	48 VDC (18 - 75 VDC)	±12 VDC	0mA	±1.25A	60mVp-p	8mA	30W	91%	±750µF
JFCW48D15-30		±15 VDC	0mA	±1.0A	60mVp-p	8mA	30W	92%	±500µF
JFCW48D24-30		±24 VDC	0mA	±0.625A	75mVp-p	10mA	30W	92%	±180µF

SPECIFICATIONS: JFCW30 SERIES

All specifications are based on 25°C, Nominal Input Voltage, and Maximum Output Current unless otherwise noted.
We reserve the right to change specifications based on technological advances.

SPECIFICATION	TEST CONDITIONS		Min	Typ	Max	Unit
INPUT SPECIFICATIONS						
Input Voltage Range	24VDC nominal input models		9	24	36	VDC
	48VDC nominal input models		18	48	75	
Start-Up Voltage	24VDC nominal input models				9	VDC
	48VDC nominal input models				18	
Shutdown Voltage	24VDC nominal input models			8		VDC
	48VDC nominal input models			16		
Input Surge Voltage (1sec, max.)	24VDC nominal input models				50	VDC
	48VDC nominal input models				100	
Input Reflected Ripple Current	Nominal Input and Full Load			30		mAp-p
Input Current	No Load			See Table		
Input Filter				Pi type		
OUTPUT SPECIFICATIONS						
Output Voltage			See Table			
Voltage Accuracy			-1.0		+1.0	%
Line Regulation	Low line to high line at full load	Single Output Models	-0.2		+0.2	%
		Dual Output Models	-0.5		+0.5	
Load Regulation	No load to full load	Single Output Models	-0.2		+0.2	%
		Dual Output Models	-1.0		+1.0	
	10% load to 90% load	Single Output Models	-0.1		+0.1	%
		Dual Output Models	-0.8		+0.8	
Cross Regulation	Asymmetrical load 25% / 100% FL, Dual Outputs		-5.0		+5.0	%
Voltage Adjustability (See Note 1)	Single Output Models	15V & 24V Output Models	-10		+20	%
		Others	-10		+10	
Output Power			See Table			
Output Current			See Table			
Minimum Load			0			%
Maximum Capacitive Load	Minimum input and constant resistive load		See Table			
Ripple & Noise (20MHz BW)		With 22µF/25V X7R 1812 MLCC	3.3V & 5V Output Models		75	mVp-p
		With two 22µF/25V X7R 1812 MLCC	12V & 15V Output Models		75	
		With two 6.8µF/50V X7R 1812 MLCC	24V Output Models		75	
		With 10µF/25V X7R 1812 MLCC for each output	±12V & ±15V Output Models		60	
		With 6.8µF/50V X7R 1812 MLCC for each output	±24V Output Models		75	
Transient Response Recovery Time	25% load step change			250		µs
Start-Up Time	Constant resistive load	Power Up			30	ms
		Remote ON/OFF			30	
Temperature Coefficient			-0.02		+0.02	%/°C
PROTECTION						
Short Circuit Protection			Continuous, automatic recovery			
Over Load Protection	% of rated full load at nominal input			170		%
Over Voltage Protection	Zener diode clamp	3.3V Output Models	3.7		5.4	VDC
		5V Output Models	5.6		7.0	
		12V Output Models	13.5		19.6	
		15V Output Models	18.3		22.0	
		24V Output Models	29.1		32.5	
Over Temperature Protection				+115		°C
GENERAL SPECIFICATIONS						
Efficiency	Nominal input voltage and full load		See Table			
Switching Frequency	3.3V & 5V Output Models		248	275	303	kHz
	Others		297	330	363	
Isolation Voltage	1 minute	Input to Output	1600			VDC
		Input to Case	1000			
		Output to Case	1000			
Isolation Resistance	500VDC		1			GΩ
Isolation Capacitance					1500	pF

SPECIFICATIONS: JFCW30 SERIES

All specifications are based on 25°C, Nominal Input Voltage, and Maximum Output Current unless otherwise noted.
We reserve the right to change specifications based on technological advances.

SPECIFICATION	TEST CONDITIONS		Min	Typ	Max	Unit
REMOTE ON/OFF (See Note 4)						
Positive Logic (standard)	Referenced to –Input pin	DC/DC ON	Open or 3 ~ 15 VDC			
		DC/DC OFF	Short or 0 ~ 1.2 VDC			
Negative Logic (optional)	Referenced to –Input pin	DC/DC ON	Short or 0 ~ 1.2 VDC			
		DC/DC OFF	Open or 3 ~ 15 VDC			
Input Current of Remote Control Pin	Nominal Vin		-0.5		1.0	mA
Remote OFF State Input Current	Nominal Vin			2.0		mA
ENVIRONMENTAL SPECIFICATIONS						
Operating Ambient Temperature	Vertical direction by natural convection (20LFM)	Without derating	-40		+50	°C
		With derating	+50		+100	
Maximum Case Temperature					+105	°C
Storage Temperature			-55		+125	°C
Thermal Impedance (See Note 6)	Natural Convection (20LFM)	Without Heatsink		15.0		°C/W
		With Heatsink		13.8		
Relative Humidity			5		95	% RH
Thermal Shock			MIL-STD-810F			
Vibration			MIL-STD-810F			
MTBF	MIL-HDBK0217F, Full Load		1,259,000 Hours			
PHYSICAL SPECIFICATIONS						
Weight			0.58oz (16.5g)			
Dimensions (L x W x H)			1.00x1.00x0.39 inch (25.4x25.4x9.9 mm)			
Case Material			Copper			
Base Material			FR4 PCB			
Potting Material			Silicon (UL94-V0)			
Shielding			Six-sided			
SAFETY & EMC CHARACTERISTICS						
Safety Approvals		IEC60950-1, UL60950-1, EN60950-1				UL: E193009 CB: UL (Demko)
EMI (See Note 2)	EN55022					Class A, Class B
ESD	EN61000-4-2	Air ±8kV, Contact ±6kV				Perf. Criteria A
Radiated Immunity	EN61000-4-3	10 V/m				Perf. Criteria A
Fast Transient (See Note 3)	EN61000-4-4	±2kV				Perf. Criteria A
Surge (See Note 3)	EN61000-4-5	±2kV				Perf. Criteria A
Conducted Immunity	EN61000-4-6	10 Vrms				Perf. Criteria A
Power Frequency Magnetic Field	EN61000-4-8	100A/m continuous; 1000A/m 1 second				Perf. Criteria A

NOTES

- Trimming allows the user to increase or decrease the output voltage set point of the module. This is accomplished by connecting an external resistor between the TRIM pin and either the +Vout pin or the –Vout pin.
- The JFCW30 series can only meet EMI Class A or Class B with external components added. See page 5 for more details.
- An external input filter capacitor is required if the module has to meet EN61000-4-4, EN61000-4-5.
-For 24VDC nominal input models we recommend connecting an aluminum electrolytic capacitor (Nippon chemi-con KY series, 220µF/100V) and a TVS (SMDJ58A, 58V, 3000 Watt peak pulse power) diode in parallel.
- For 48VDC nominal input models we recommend an aluminum electrolytic capacitor (Nippon chemi-con KY series, 220µF/100V).
- Both positive logic and negative logic remote ON/OFF control is available. Positive logic remote ON/OFF comes standard; for negative logic remote ON/OFF add the suffix “R” to the model number (Ex: JFCW24S05-30R).
- There are several different options available for this series. Please see the “Model Number Setup” on page 5 for all options and ordering information.
- Optional heatsink is available. Please call factory for more information.

CAUTION: This power module is not internally fused. An input line fuse must always be used.

Due to advances in technology, specifications subject to change without notice.

DERATING CURVES

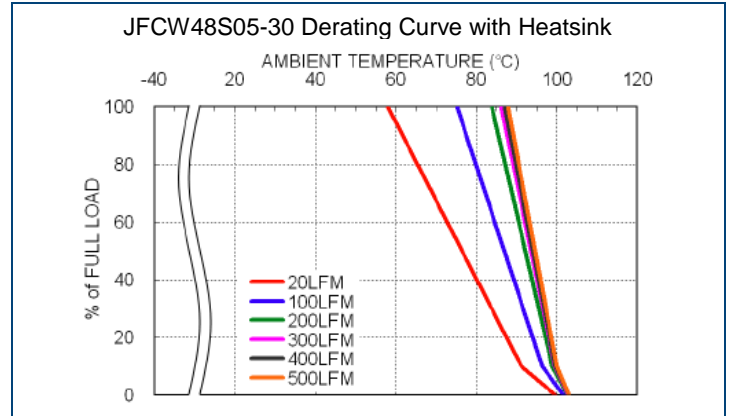
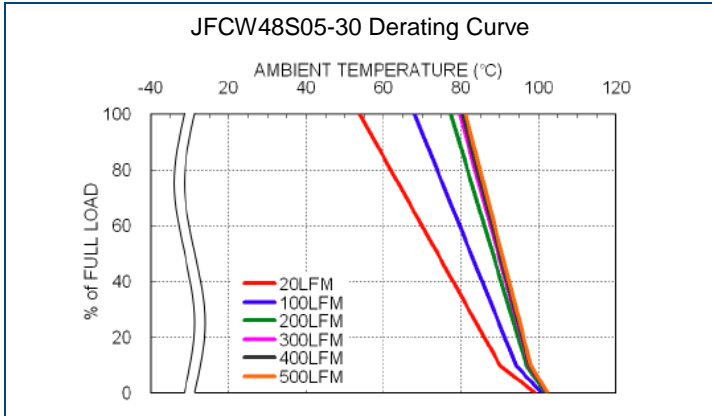

EFFICIENCY CURVES

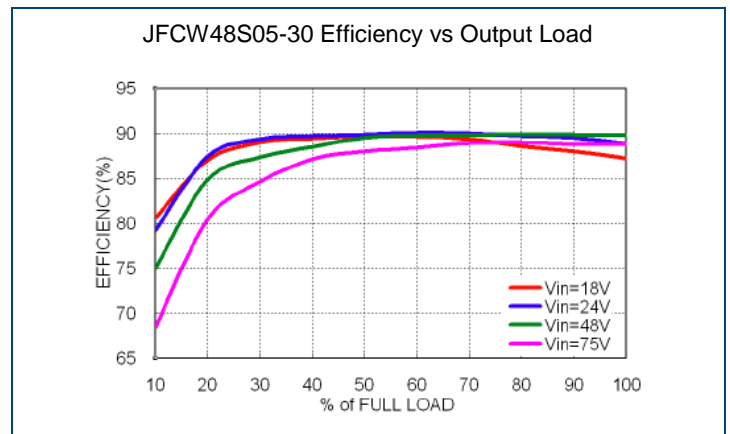
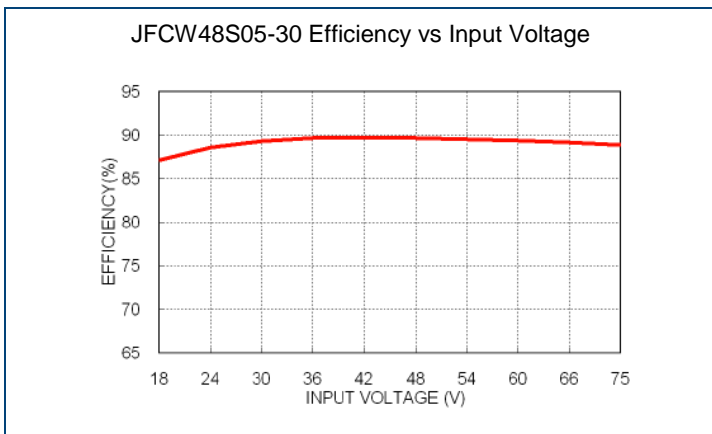

MECHANICAL DRAWING

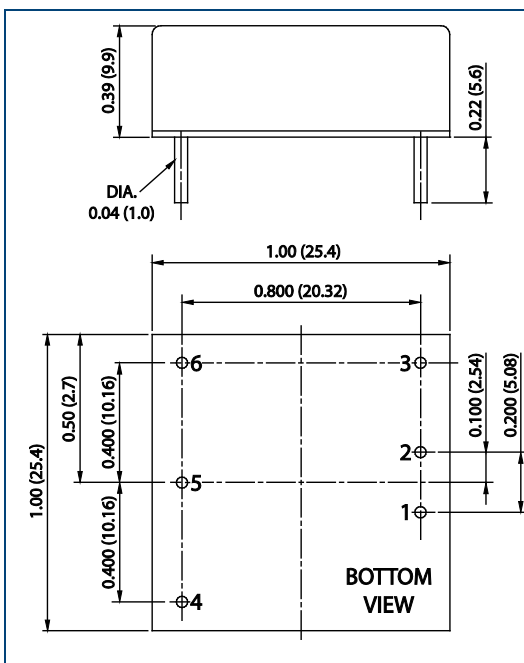

PIN CONNECTIONS		
PIN	SINGLE	DUAL
1	+INPUT	+INPUT
2	-INPUT	-INPUT
3	CTRL	CTRL
4	+OUTPUT	+OUTPUT
5	TRIM	COMMON
6	-OUTPUT	-OUTPUT

PRODUCT OPTIONS	
OPTION	SUFFIX
Positive Logic	None
Negative Logic	R
Without CTRL Pin	D
Without CTRL and TRIM Pins	G
Positive Logic without TRIM Pin	F
Negative Logic without TRIM Pin	RF
Heatsink	HC

- NOTES**
- Unit: inches (mm)
 - Tolerance: X.XX±0.02 (X.X±0.5)
X.XXX±0.01 (X.XX±0.25)
 - Pin Pitch Tolerance: ±0.01 (±0.25)
 - Pin Dimension Tolerance: ±0.004 (±0.1)
 - All dimensions are for reference only

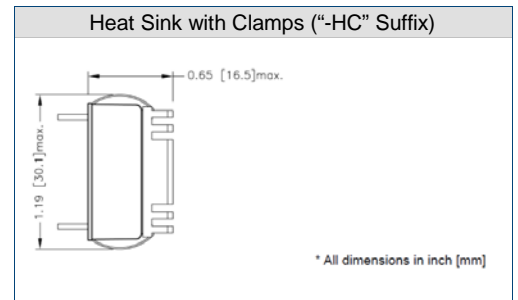

RECOMMENDED PAD LAYOUT

Standard

Heat Sink Option

Notes: All dimensions in inch [mm]
 Pad Size (lead free recommended)
 Through Hole 1.2.3.4.5.6: $\Phi 0.051$ [$\Phi 1.30$]
 Top View Pad 1.2.3.4.5.6: $\Phi 0.064$ [$\Phi 1.63$]
 Bottom View Pad 1.2.3.4.5.6: $\Phi 0.102$ [2.60]

EMI CONSIDERATIONS

Recommended Filter for EN5022 Class A Compliance

Model	C1	L1
JFCW24SXX-30	4.7 μ F/50V 1812 MLCC	2.2 μ F SMD Inductor PMT-097
JFCW48SXX-30	4.7 μ F/100V 1812 MLCC	10 μ F SMD Inductor PMT-070

Recommended Filter for EN5022 Class B Compliance

Model	C1	C2	C3	C4 & C5	L1
JFCW24SXX-30	4.7 μ F/50V 1812 MLCC	4.7 μ F/50V 1812 MLCC	4.7 μ F/50V 1812 MLCC	1000pF/2kV 1206 MLCC	2.2 μ F SMD Inductor PMT-097
JFCW48SXX-30	4.7 μ F/100V 1812 MLCC	4.7 μ F/100V 1812 MLCC	4.7 μ F/100V 1812 MLCC	2200pF/2kV 1206 MLCC	10 μ F SMD Inductor PMT-070

Recommended EN5022 Class A Filter Circuit Layout

Recommended EN5022 Class B Filter Circuit Layout

COMMON MODE CHOKES

PMT-070		PMT-097	
Inductance: 10μH±20%	Unit: mm	Inductance: 2.2μH±20%	Unit: mm
Impedance: 40mΩ		Impedance: 12mΩ	
Rated Current: 2.6A		Rated Current: 11A	

FUSE CONSIDERATIONS

This power module is not internally fused. An input line fuse must always be used. This encapsulated power module can be used in a wide variety of applications, ranging from simple stand-alone operations to an integrated part of sophisticated power architecture. To maximum flexibility, internal fusing is not included; however to achieve maximum safety and system protection, always use an input line fuse. The suggested input line fuse is:

Model	Fuse Rating (A)	Fuse Type
24VDC Nominal Input Models	6A	Slow-Blow
48VDC Nominal Input Models	2A	Slow-Blow

The table is based on information provided in the data sheet on inrush energy and maximum DC input current at low Vin.

THERMAL CONSIDERATIONS

This power module operates in a variety of thermal environments. However, sufficient cooling should be provided to help ensure reliable operation of the unit. Heat is removed by conduction, convection, and radiation to the surrounding environment. Proper cooling can be verified by measuring the point as shown in the figure below. The temperature at this location should not exceed 105°C. When operating, adequate cooling must be provided to maintain the test point temperature at or below 105°C. Although the maximum point temperature of the power modules is 105°F, you can limit this temperature to a lower value for extremely high reliability.

Thermal test condition with vertical direction by natural convection (20LFM).

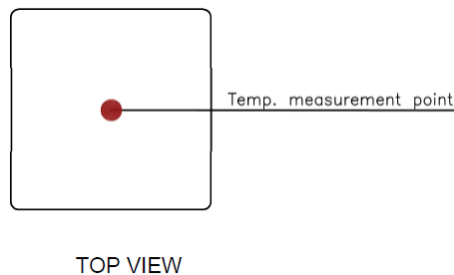

OUTPUT VOLTAGE ADJUSTMENT

Output voltage set point adjustment allows the user to increase or decrease the output voltage set point of the module. This is accomplished by connecting an external resistor between the Trim pin and either the +Output or –Output pins.

With external resistor between the Trim and –Output pin, the output voltage set increases.

With an external resistor between the Trim and +Output pin, the output voltage set point decreases.

The external Trim resistor needs to be at least 1/16W of rated power.

Trim Up Equation

$$R_U = \left[\frac{G \times L}{(V_{O,up} - L - K)} - H \right] \Omega$$

Trim Constants

Module	G	H	K	L
JFCWxxS33-30	5110	2050	0.8	2.5
JFCWxxS05-30	5110	2050	2.5	2.5
JFCWxxS12-30	10000	5110	9.5	2.5
JFCWxxS15-30	10000	5110	12.5	2.5
JFCWxxS24-30	56000	13000	21.5	2.5

Trim Down Equation

$$R_D = \left[\frac{(V_{O,down} - L) \times G}{(V_o - V_{O,down})} - H \right] \Omega$$

External Output Trimming

Output can be externally trimmed using the method shown below

Trim Up

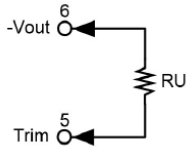

3.3VDC Single Output Models

ΔV (%)	1	2	3	4	5	6	7	8	9	10
Vout (V)	3.333	3.366	3.399	3.432	3.465	3.498	3.531	3.564	3.597	3.630
RU (kΩ)	385.071	191.511	126.990	94.730	75.374	62.470	53.253	46.340	40.963	36.662

5VDC Single Output Models

ΔV (%)	1	2	3	4	5	6	7	8	9	10
Vout (V)	5.050	5.100	5.150	5.200	5.250	5.300	5.350	5.400	5.450	5.500
RU (kΩ)	253.450	125.700	83.117	61.825	49.050	40.533	34.450	29.888	26.339	23.500

12VDC Single Outputs Models

ΔV (%)	1	2	3	4	5	6	7	8	9	10
Vout (V)	12.120	12.240	12.360	12.480	12.600	12.720	12.840	12.960	13.080	13.200
RU (kΩ)	203.223	99.057	64.334	46.973	36.557	29.612	24.652	20.932	18.038	15.723

15VDC Single Output Models

ΔV (%)	1	2	3	4	5	6	7	8	9	10
Vout (V)	15.150	15.300	15.450	15.600	15.750	15.900	16.050	16.200	16.350	16.500
RU (kΩ)	161.557	78.223	50.446	36.557	28.223	22.668	18.700	15.723	13.409	11.557

ΔV (%)	11	12	13	14	15	19	17	18	19	20
Vout (V)	16.650	16.800	16.950	17.100	17.250	17.400	17.550	17.700	17.850	18.00
RU (kΩ)	10.042	8.779	7.711	6.795	6.001	5.307	4.694	4.149	3.662	3.223

24VDC Single Output Models

ΔV (%)	1	2	3	4	5	6	7	8	9	10
Vout (V)	24.240	24.480	24.720	24.960	25.200	25.440	25.680	25.920	26.160	26.400
RU (kΩ)	570.333	278.667	181.444	132.833	103.667	84.222	70.333	59.917	51.815	45.333

ΔV (%)	11	12	13	14	15	19	17	18	19	20
Vout (V)	26.640	26.880	27.120	27.360	27.600	27.840	28.080	28.320	28.560	28.800
RU (kΩ)	40.030	35.611	31.872	28.667	25.889	23.458	21.314	19.407	17.702	16.167

Trim Down

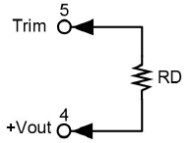

3.3VDC Single Output Models

ΔV (%)	1	2	3	4	5	6	7	8	9	10
Vout (V)	3.267	3.234	3.201	3.168	3.135	3.102	3.069	3.036	3.003	2.970
RU (kΩ)	116.719	54.779	34.133	23.810	17.616	13.486	10.537	8.325	6.604	5.228

5VDC Single Output Models

ΔV (%)	1	2	3	4	5	6	7	8	9	10
Vout (V)	4.950	4.900	4.850	4.800	4.750	4.700	4.650	4.600	4.550	4.500
RU (kΩ)	248.340	120.590	78.007	56.715	43.940	35.423	29.340	24.778	21.229	18.390

12VDC Single Output Models

ΔV (%)	1	2	3	4	5	6	7	8	9	10
Vout (V)	11.880	11.760	11.640	11.520	11.400	11.280	11.160	11.040	10.920	10.800
RU (kΩ)	776.557	380.723	248.779	182.807	143.223	116.834	97.985	83.848	72.853	64.057

15VDC Single Output Models

ΔV (%)	1	2	3	4	5	6	7	8	9	10
Vout (V)	14.850	14.700	14.550	14.400	14.250	14.100	13.950	13.800	13.650	13.500
RU (kΩ)	818.223	401.557	262.668	193.223	151.557	123.779	103.938	89.057	77.483	68.223

24VDC Single Output Models

ΔV (%)	1	2	3	4	5	6	7	8	9	10
Vout (V)	23.760	23.520	23.280	23.040	22.800	22.560	22.320	22.080	21.840	21.600
RU (kΩ)	49473667	2439.333	1603.222	1185.167	934.333	767.111	647.667	558.083	488.407	432.667

MODEL NUMBER SETUP

JFCW	24	S	05	-	30	R	H
Series Name	Input Voltage	Output Quantity	Output Voltage		Output Power	Remote ON/OFF, CTRL, and TRIM Pins	Heatsink
	24: 9-36V 48: 18-75V	S: Single Output D: Dual Output	33: 3.3VDC 05: 5VDC 12: 12VDC 15: 15VDC 24: 24VDC 12: ±12VDC 15: ±15VDC 24: ±24VDC		30: 30W	None: Positive Logic R: Negative Logic D: Without CTRL Pin G: Without CTRL and TRIM Pins F: Positive Logic w/out TRIM Pin RF: Negative Logic w/out TRIM Pin	None: No Heatsink HC: Heatsink

COMPANY INFORMATION

Wall Industries, Inc. has created custom and modified units for over 50 years. Our in-house research and development engineers will provide a solution that exceeds your performance requirements on-time and on budget. Our ISO9001-2008 certification is just one example of our commitment to producing a high quality, well-documented product for our customers.

Our past projects demonstrate our commitment to you, our customer. Wall Industries, Inc. has a reputation for working closely with its customers to ensure each solution meets or exceeds form, fit and function requirements. We will continue to provide ongoing support for your project above and beyond the design and production phases. Give us a call today to discuss your future projects.

Contact **Wall Industries** for further information:

Phone: ☎ (603)778-2300
Toll Free: ☎ (888)597-9255
Fax: ☎ (603)778-9797
E-mail: sales@wallindustries.com
Web: www.wallindustries.com
Address: 37 Industrial Drive
Exeter, NH 03833