

# MAX5216LPT Evaluation Kit

# Evaluates: Reference Design of 4–20mA Loop-Powered Transmitter

## General Description

The MAX5216LPT evaluation kit (EV kit) enables evaluation of the loop-powered 4–20mA current-loop transmitter with the fault current-limiting capabilities and Highway Addressable Remote Transducer (HART) modem input/output ready, which utilizes the MAX5216 single-channel, low-power, buffered-output, 3-wire SPI interface 16-bit DAC, the MAX6133 3ppm/°C, low-power voltage reference, the MAX9620 single-channel, zero-drift, high-efficiency op amp with RRIO, and the MAX15007 40V, ultra-low quiescent current LDO. The EV kit also includes Windows XP®, Windows Vista® and Windows® 7-compatible software that provides a simple graphical-user interface (GUI) for exercising the features of this reference design.

*Ordering Information appears at end of data sheet.*

## Component List

DESIGNATION	QTY	DESCRIPTION
C2, C16	2	1µF ±10%, 50V X7R ceramic capacitors (0805) Murata GRM21BR71H105KA12
C3	1	0.1µF ±10%, 50V X7R ceramic capacitor (0805) Murata GRM21BR71H104KA01
C4	1	10µF ±10%, 16V X5R ceramic capacitor (0805) Taiyo Yuden EMK212BJ106KG-T
C5, C6, C10, C12–C14, C18, C21	8	0.1µF ±10%, 16V X7R ceramic capacitors (0603) Murata GRM188R71C104K
C7, C8, C17	3	1000pF ±10%, 50V X7R ceramic capacitors (0603) Murata GRM188R71H102KA01

*Windows, Windows XP, and Windows Vista are registered trademarks and registered service marks of Microsoft Corporation.*

## Features

- Wide 12V to 40V Input Supply Range
- Transfer 16-Bit Digital Code to 4–20mA Loop Current
- Offset and Gain Programmable
- < 0.02 % FS Current Error at +25°C
- < 0.1 % FS Current Error Over Temperature Range
- -40°C to +105°C Temperature Range
- 30mA ±20% Resistor-Selectable Current Limiting
- 200µA (typ), 300µA (max) Quiescent Current
- HART Modem Input and Output Ready
- Direct USB Communication through the MAXQ622 Microcontroller
- Windows XP-, Windows Vista-, and Windows 7 (32-Bit)-Compatible Software
- SPI Interface Terminals
- Proven PCB Layout
- Fully Assembled and Tested

DESIGNATION	QTY	DESCRIPTION
C9, C11, C15, C19, C20, C22, C25	7	1µF ±10%, 16V X7R ceramic capacitors (0603) Murata GRM188R71C105K
C23, C24	2	18pF ±5%, 50V COG ceramic capacitors (0603) Murata GRM1885C1H180J
D1	1	Schottky diode (SC79) NXP RB751S40,115
D2	1	TVS diode (SMA) Burns SMAJ36CA
FB1	1	600Ω ferrite bead (0805) API Delevan EMI0805R-600
J1	1	Mini-USB type-B, right-angle PC-mount receptacle Hirose UX60A-MB-5ST
J2	0	Not installed, 10-pin (2 x 5) header, 0.1in centers

## Component List (continued)

DESIGNATION	QTY	DESCRIPTION
J3–J7, J9, J11	6	2-pin headers, 0.1in centers Sullins PEC36SAAN
J8	1	3-pin header. 0.1in center Sullins PEC36SAAN
J10	1	2.54mm, 2-position, side-entry terminal block Phoenix Contact 1725656
Q1	1	N-channel MOSFET (SOT223) Fairchild NDT014L
Q2	1	Bipolar npn transistor (SOT23) NXP MMBT3904,215
R1	1	287k $\Omega$ $\pm$ 0.1%, 1/10W resistor (0603) Panasonic ERA-3AEB2873V
R2	1	24.9k $\Omega$ $\pm$ 0.1%, 1/10W resistor (0603) Susumu RG1608P-2492-B
R3	1	2M $\Omega$ $\pm$ 1%, 1/10W resistor (0603) ROYALOHM TC0650F2004T4E
R4, R8	2	301 $\Omega$ $\pm$ 1%, 1/10W resistors (0603) Panasonic ERJ-3EKF3010V
R5, R12, R18	3	1k $\Omega$ $\pm$ 1%, 1/10W resistors (0603) Panasonic ERJ-3EKF1001V
R6, R15–R17	4	24.3 $\Omega$ $\pm$ 1%, 1/10W resistors (0603) Panasonic ERJ-3EKF24R3V
R7	1	100 $\Omega$ $\pm$ 0.1%, 1/10W resistor (0603) Panasonic ERA-3AEB101V
R9, R10	2	10k $\Omega$ $\pm$ 1%, 1/10W resistors (0603) Panasonic ERJ-3EKF1002V
R11, R13	2	49.9k $\Omega$ $\pm$ 1%, 1/10W resistor (0603) Panasonic ERJ-3EKF4992V

DESIGNATION	QTY	DESCRIPTION
R14, R19, R22–R24	5	100 $\Omega$ $\pm$ 1%, 1/10W resistors (0603) Panasonic ERJ-3EKF101V
R20	1	3.3k $\Omega$ $\pm$ 1%, 1/10W resistor (0603) Panasonic ERJ-3EKF3301V
RS	1	10 $\Omega$ $\pm$ 0.1%, 1/10W resistor (0603) Bourns CRT0603BY10R0ELF
TP1	1	Red PC test point, compact 0.06in Kobiconn 151-107-RC
TP2	1	Black PC test point, compact 0.06in Kobiconn 151-103-RC
TP3–TP13	11	Turret terminal pins Mill-Max 2108-2-00-44-00-00-07-0
U1	1	16-bit VOUT DAC (8 $\mu$ MAX <sup>®</sup> ) Maxim MAX5216GUA+
U2	1	Single zero-drift RRIO op amp (5 SC70) Maxim MAX9620AXK+
U3	1	2.5V, 3ppm/ $^{\circ}$ C, low-power voltage reference (8 $\mu$ MAX) Maxim MAX6133A25+
U4	1	3.3V, ultra-low quiescent current, LDO (6 TDFN) Maxim MAX15007AATT+
U5	1	16-bit microcontroller with USB 2.0 interface (64 LQFP) Maxim MAXQ622G-0000+
Y1	1	12MHz crystal oscillator (HC49US) Citizen HCM49-12.000MABJ-UT
—	1	PCB: MAX5216LPT Rev. A

$\mu$ MAX is a registered trademark of Maxim Integrated Products, Inc.

### Component Suppliers

SUPPLIER	PHONE	WEBSITE
API Delevan	408-865-0344	www.delevan.com
Bourns, Inc.	408-496-0706	www.bourns.com
Citizen America Corp.	310-781-1460	www.citizencrystal.com
Fairchild Semiconductor	888-522-5372	www.fairchild.com
Hirose Electric Co., Ltd.	81-3-3491-9741	www.hirose.com
Kobiconn	800-346-6873	www.mouser.com/kobiconn
Murata Electronics North America, Inc.	770-436-1300	www.murata-northamerica.com
NXP Semiconductors	408-474-8142	www.nxp.com
Panasonic Corp.	800-344-2112	www.panasonic.com
Sullins Electronics Corp.	760-744-0125	www.sullinselectronics.com
Susumu International USA	208-328-0307	www.susumu-usa.com

**Note:** Indicate that you are using the MAX5216LPT when contacting these component suppliers.

### Quick Start

#### Required Equipment

- MAX5216LPT EV kit
- The EV kit board is a plug-n-play device that connects to the PC through a USB-A to Mini-B cable.
- The EV kit is preloaded with the default firmware that communicates with the MAX5216LPT evaluation software. Software can be installed and run on Windows XP, Windows Vista, and Windows 7-based systems.

**Note:** In the following sections, software-related items are identified by bolding. Text in **bold** refers to items directly from the EV kit software. Text in **bold and underlined** refers to items from the Windows operating system.

#### Procedure

The EV kit is fully assembled and tested. Follow the steps below to verify board operation:

- 1) Visit [www.maximintegrated.com/design/tools/applications/evkit-software/](http://www.maximintegrated.com/design/tools/applications/evkit-software/) to download the latest version of the EV kit software, MAX5216LPTGUIVxx.ZIP. Unzip the file and run the setup.exe. Follow the instructions to install the evaluation software on your PC. The program files are copied and icons are created in the Windows **Start | Programs** menu.
- 2) Connect the MAX5216LPT to the PC through a USB cable. No additional driver is needed; Windows recognizes the new device as a human interface device (HID) and automatically finds and installs the appropriate driver for it. For more information, check the device properties in:

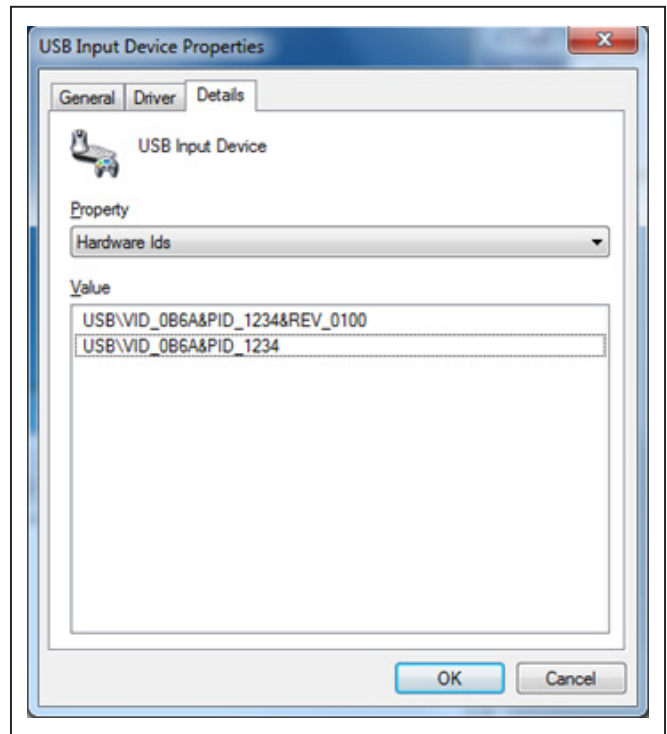

Figure 1. USB Input Device Properties

Device Manager\Human Interface Control\USB Input Device\Properties - > USB\VID\_0B6A&PID\_1234. See Figure 1.

- 3) Run the MAX5216LPT.exe program. The application's GUI appears, as shown in Figure 2.

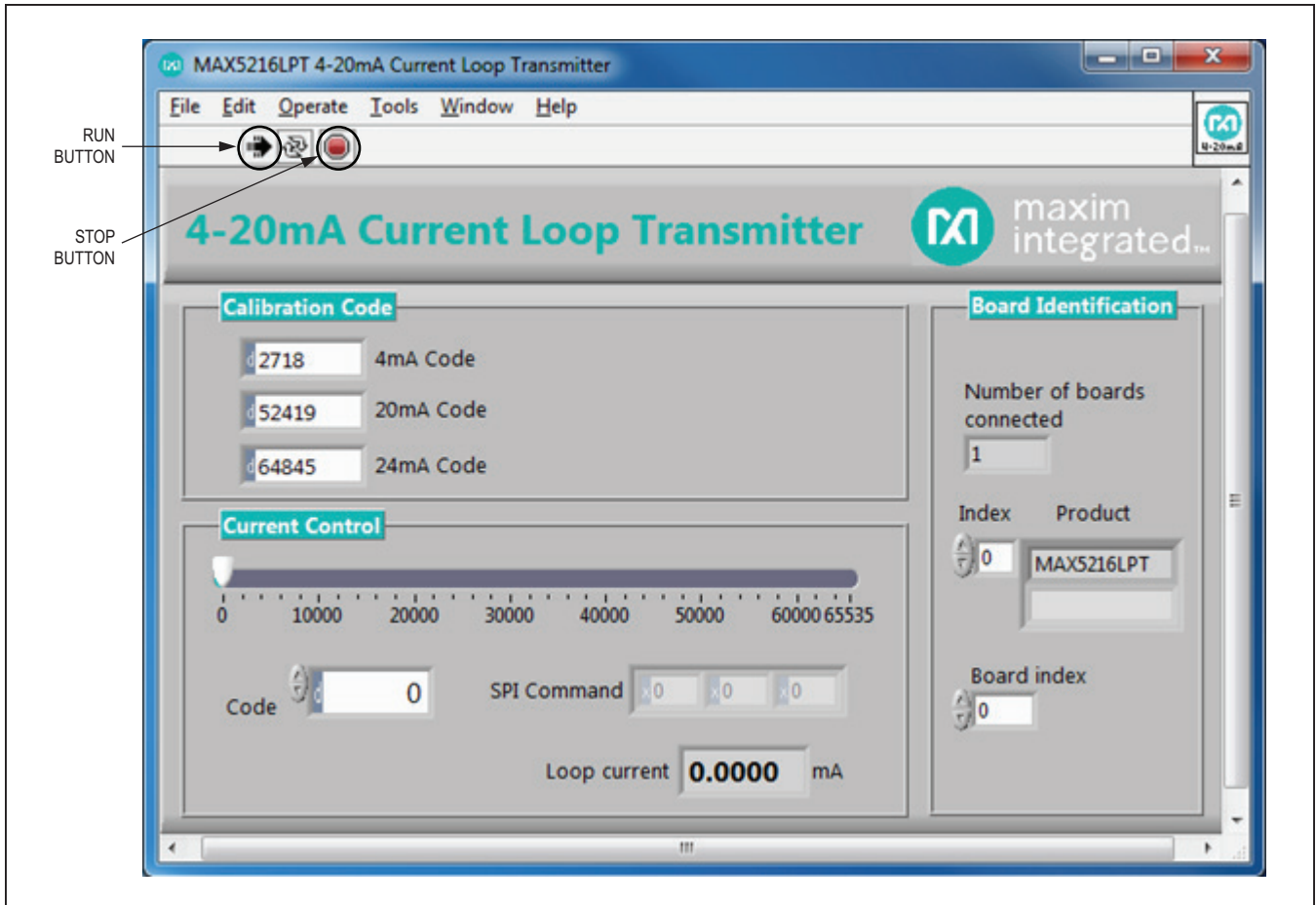

Figure 2. MAX5216LPT GUI

### Detailed Description of Software

The MAX5216LPT EV kit GUI (Figure 2) is active by default. The application checks all the boards with the USB VID/PID 0x0B6A/0x1234 that connected to the PC and indicates them on the right side of the GUI. Up to 16 boards can be connected to the system. Each board has its own unique board index. Select the appropriate board index from the **Board index** spin box (Figure 3).

The EV kit board has to be calibrated first for proper operation. Connect an external 12V to 40V power supply between the LOOP+ (TP1) and LOOP- (TP2) test points or to the J10 connector (see the Figure 13a schematic).

It is strongly recommended to use an isolated power supply. Connect a precision digital voltmeter (DVM) across the precision load. The on-board 100Ω 0.1% R7 resistor can be used as precision load for quick calibration. In this case, remove the J9 shunt and place the DVM across the J9 header. With the 100Ω load, the DVM should display less than 0.350V. This means that the board consumes less than 3.5mA current. Move the track-bar slider to the right until the DVM displays approximately 0.4V. Use the up/down arrow buttons next to **Code** control spin box to fine tune to an exact 400mV drop across the R7 sense resistor. Type that code into the **Calibration Code** group box in the field labeled **4mA Code**.

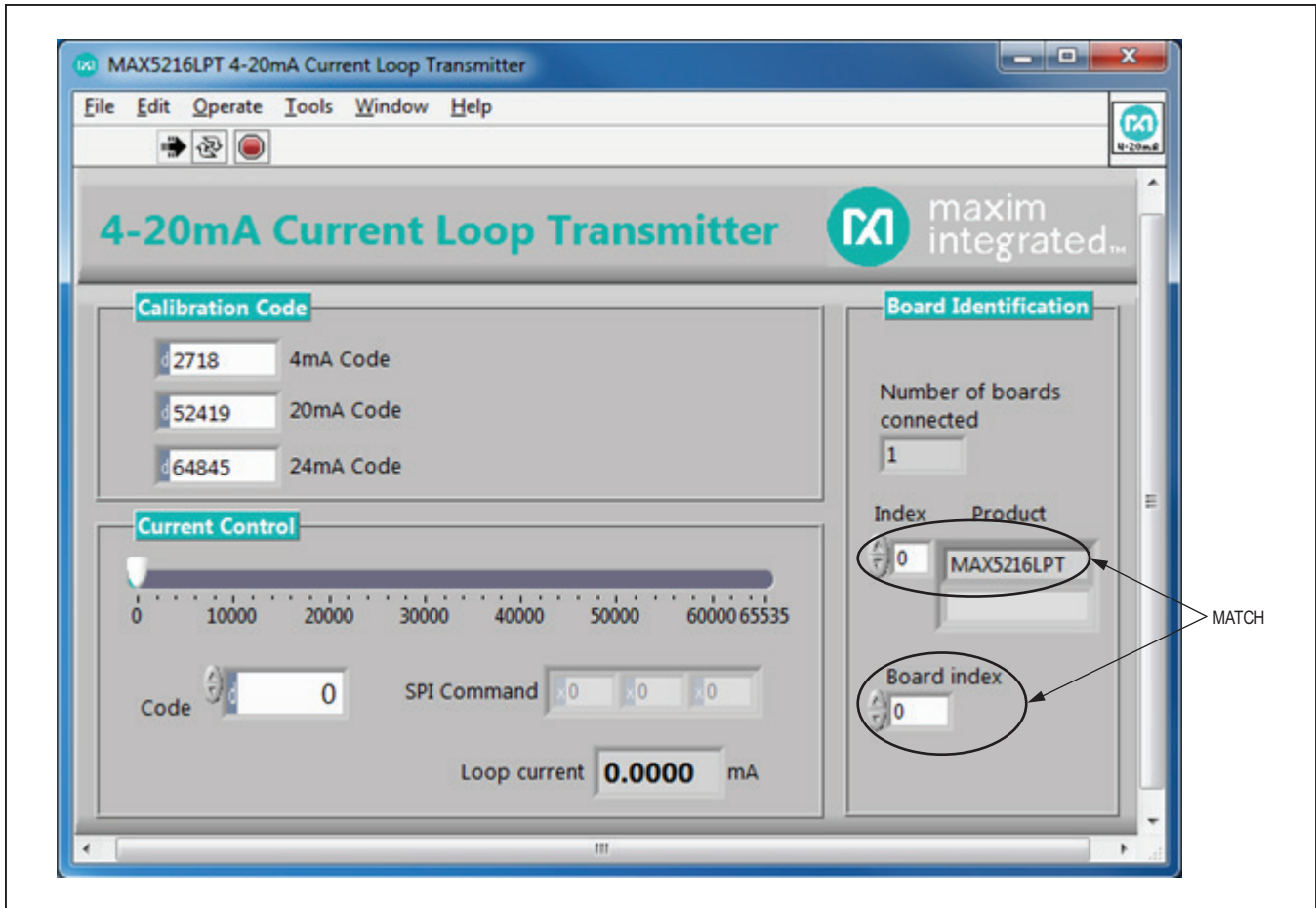

Figure 3. Select the Board Index in the System with the Multiple Boards

Continue the same procedure to find the calibration code for 20mA loop current. The DVM indicates 2.000V across R7 when loop current reaches 20mA. Type in the 20mA code into the **Calibration Code** group box in the field labeled **20mA Code**. The loop current can also be set by typing in a decimal, hexadecimal, or an octal or a binary value in the **Code Control** spin box (Figure 4). The board accepts codes from 0 to 65535 ( $2^{16}-1$ ) decimal or from 0 to FFFF hex. The notation is displayed on the left side of the box.

Now when the track-bar slider position is changed, the correct current is indicated in the **Loop current** box of the GUI. The calibration code for 4mA and 20mA loop current can be written on the board itself to avoid calibration procedures in the future, as shown in Figure 5. The same procedure can be continued to find the appropriate code for 24mA loop current, if applicable.

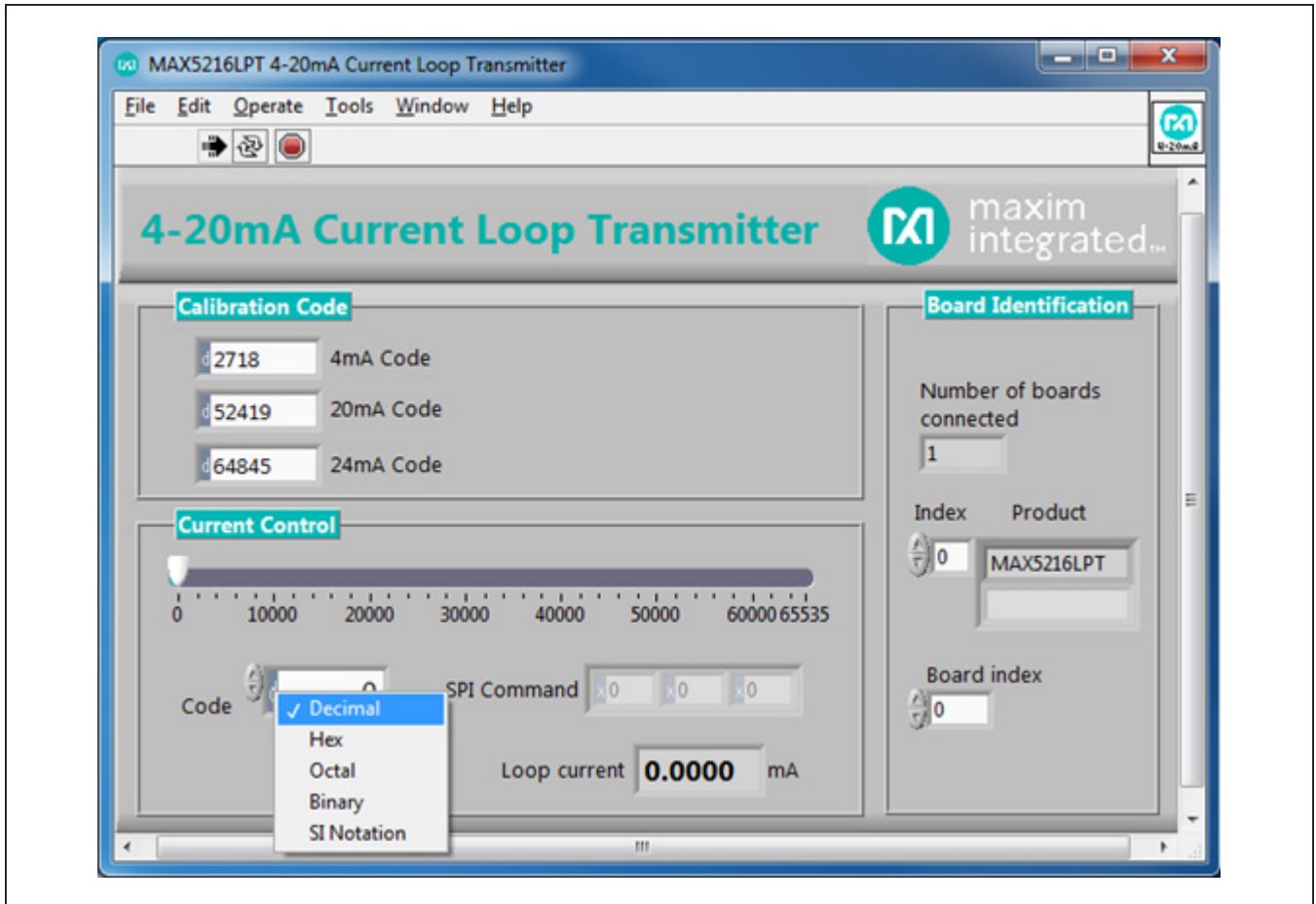

Figure 4. Notation Selection Dialog Box

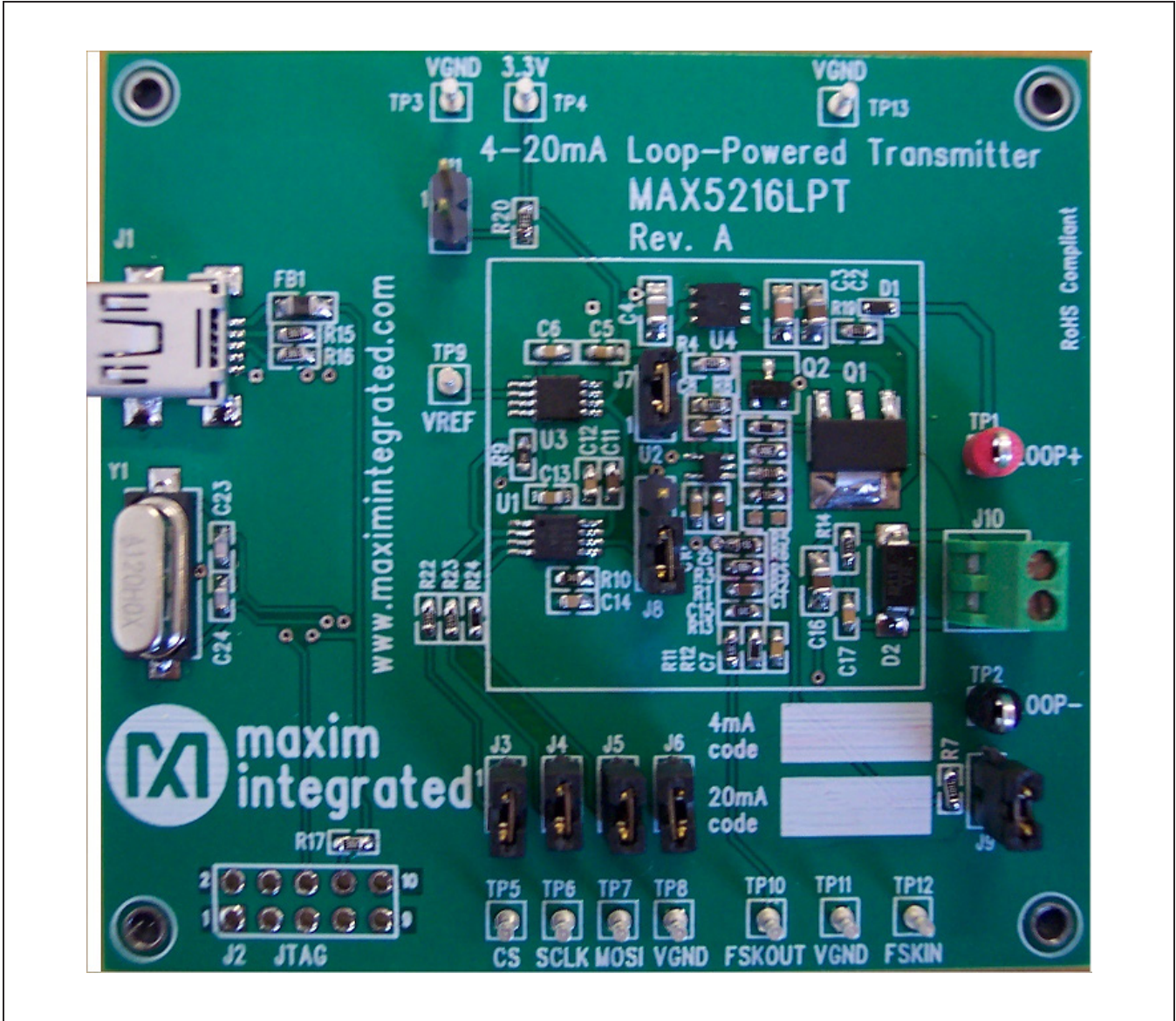

Figure 5. MAX5216LPT Board

Detailed Description of Hardware

The MAX5216LPT EV kit board is loaded with the MAX5216, Maxim’s best-in-class lowest power 16-bit DAC (U1), the MAX6133A25 voltage reference (U3), the MAX9620 zero-drift, RRIO high-precision op amp (U2), and the MAX15007 40V low-quiescent current LDO (U4). See the block diagram in Figure 6 and the schematics in Figures 13a and 13b. The on-board MAX6133A25 (U3) provides low temperature drift of 3ppm/°C, low quiescent current, and 2.500V precise voltage reference for the DAC. The MAX5216 (U1) receives a command from the 16-bit MAXQ622 microcontroller (U5) through a 3-wire high-speed SPI bus, which emulates the smart sensor; then its output is divided and converted into the loop current by the MAX9620 (U2) op amp, Q1 power MOSFET, and 10Ω ±0.1% sense resistor (R<sub>SENSE</sub>). The U1–U3

devices are powered by the MAX15007, a 3.3V low-noise LDO voltage regulator (U4), which gets power from an external power supply. There is a current-limiting circuitry made on the Q2 BJT transistor and sense resistor R6. This circuitry limits the loop current to approximately 30mA, which prevents runaway conditions and damaging an ADC on the programmable logic controller (PLC) side. The Schottky diode (D1) and transient voltage suppressor (D2) are safety devices that protect the transmitter from reverse current flow and overvoltage surge conditions.

The U1 device can run at 50MHz clock frequency, but the SPI bus speed is limited to 6MHz on this board by the U5 microcontroller. The evaluation software allows setting the loop current through the full-speed USB 2.0 bus and the U5 microcontroller. The microcontroller is preloaded with the firmware that communicates with the GUI.

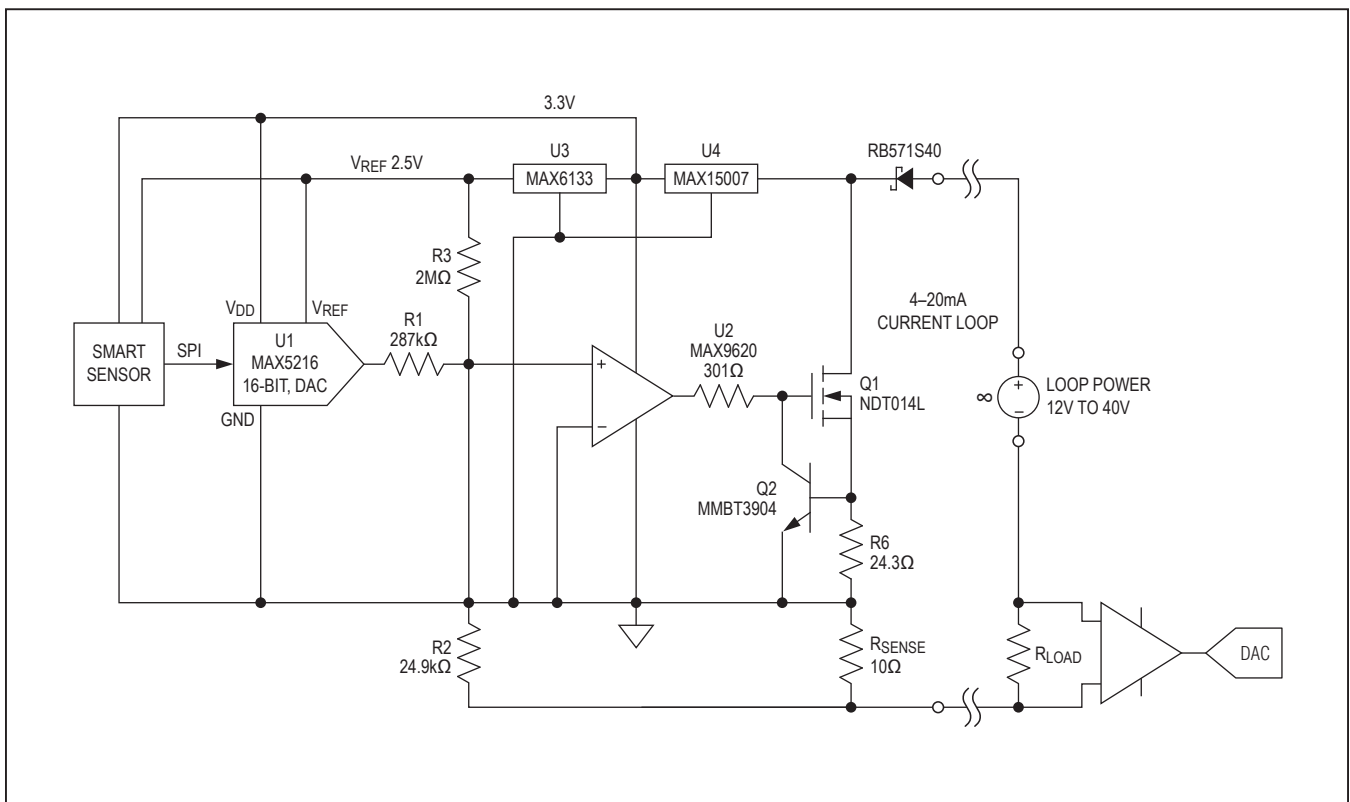

Figure 6. MAX5216LPT EV Kit Block Diagram

**Principles of Operation and Key Design Parameters**

The block diagram shown in Figure 6 allows for the designing of a high-performance, low-power, low component count 4–20mA current-loop transmitter that gives the best result for the price vs. performance solution.

The low-power, high-performance components need to be selected to meet the 0.1% current-error requirements of the 4–20mA current loop. The maximum current consumption of the selected components is less than 300µA over -40°C to +105°C temperature range. In addition to low power, the 25µV (max) zero-drift input offset voltage over time and temperature of the MAX9620 makes this op amp ideal for the accuracy and stability of this circuitry. The U2 op amp is tracking the voltage drop across the R2 and R<sub>SENSE</sub> resistors and maintains 0V at both its input nodes.

The following equations are used for this circuitry:

$$I_{OUT} = I(R2) \times \frac{R2}{R_{SENSE}} \quad \text{EQ1}$$

$$I(R2) = I(R1) + I(R3) \quad \text{EQ2}$$

where:

I<sub>OUT</sub> is the loop current,

I(R2) is the current flowing through the R2 resistor,

I(R1) is the current flowing through the R1 resistor, and

I(R3) is the current flowing through the R3 resistor.

In EQ2, we assume that the input current to IN+ and to IN- of U2 is 0.

According to EQ1 and EQ2, the initial loop current of 4mA is set by the I(R3) current, while I(R1) is 0.

Thus:

$$I_{OUT_{INIT}} = I(R3) \times \frac{R2}{R_{SENSE}} \quad \text{EQ3}$$

Current through the R3 resistor is equal to the U3 output divided by R3, and equation EQ3 can be overwritten as follows:

$$I_{OUT_{INIT}} = \frac{V_{REF}}{R3} \times \frac{R2}{R_{SENSE}} \quad \text{EQ4}$$

According to Namur NE43 recommendations for failure information transmitted over 4–20mA current loop, the signal range for measurement information is from 3.8mA to 20.5mA, allowing for a small amount of linear over-range process readings. The actual supported range of this board is from 3.2mA to 24.6mA. Solving the EQ4 for R3 having:

$$R3 = V_{REF} \times \frac{R2}{R_{SENSE} \times I_{OUT_{INIT}}} = 2.5 \times \frac{24.9 \times 10^3}{10 \times 3.2 \times 10^{-3}} = 1.945 \times 10^6 (\Omega) \quad \text{EQ5}$$

Since the cost to maintain the exact 1.945MΩ resistor is too high and is not well suited for the automated production and easy field calibration, it is recommended to use a regular 1% tolerance resistor and regain the accuracy by calibrating out the 4mA offset current and the 20mA full-scale current by the U1 DAC. In this case, some digital codes are used for calibration purposes to maintain the required accuracy.

The I(R1) = V<sub>DAC</sub>/R1, where V<sub>DAC</sub> is the U1 DAC output voltage, and can be overwritten as:

$$I(R1) = \frac{V_{REF} \times \text{CODE}}{65535 \times R1} \quad \text{EQ6}$$

And:

$$I(R3) = \frac{V_{REF}}{R3} \quad \text{EQ7}$$

Finally, the EQ1 can be overwritten as:

$$I_{OUT} = V_{REF} \times \left[ \frac{\text{CODE}}{65535 \times R1} + \frac{1}{R3} \right] \times \frac{R2}{R_{SENSE}} \quad \text{EQ8}$$

The error analysis of passive components and V<sub>REF</sub> of the 4–20mA current-loop transmitter based on EQ8 can be seen in Table 1.

**Note:** The 4–20mA Transmitter Design Calculator/Error Analyzer spreadsheet is available at [www.maximintegrated.com/design/tools/calculators/product-design](http://www.maximintegrated.com/design/tools/calculators/product-design) page. It is recommended to use the What-If Analysis/Goal-Seek feature from the Data tab to find the appropriate code for 4mA, 20mA, and 24mA I<sub>OUT</sub>.

**Table 1. 4–20mA Current-Loop Transmitter Error Analysis**

COMPONENT	TOL (±%)	MINIMUM	NOMINAL	MAXIMUM	UNITS
V <sub>REF</sub>	0.04	2.4990	2.5000	2.5010	V
R1	0.1	286.71	287	287.29	kΩ
R2	0.1	24.88	24.9	24.92	kΩ
R3	1	1980.00	2000	2020.00	kΩ
R <sub>SENSE</sub>	0.1	0.00999	0.0100	0.01001	kΩ
—	—	<b>MINIMUM</b>	<b>NOMINAL</b>	<b>MAXIMUM</b>	<b>UNITS</b>
Zero-scale DAC code		0	0	0	Decimal
Zero-scale I <sub>OUT</sub>		3.07430	3.11250	3.15149	mA
4mA DAC code		2806	2682	2555	Decimal
4mA I <sub>OUT</sub>		3.99984	4.00015	3.99999	mA
Full-scale DAC code		65535	65535	65535	Decimal
Full-scale I <sub>OUT</sub>		24.69058	24.8024	24.91527	mA
20mA DAC code		51314	51025	50734	Decimal
20mA I <sub>OUT</sub>		19.99988	20.00007	19.99995	mA
4mA error		-0.00410	0.00381	-0.00016	% FS
20mA error		-0.00061	0.00035	-0.00026	% FS
24mA I <sub>OUT</sub> DAC code		63441	63111	62779	Decimal
24mA I <sub>OUT</sub>		23.99989	24.00013	24.00002	mA

**Note:** Shaded cells indicate *TBD*.

In this case, having the standard 1% tolerance 2MΩ R3 resistor, and setting the U1 to 2682 decimal code, the initial loop current of 4.00015mA is maintained.

Note that the total calculated error is much less than the tolerance of the individual components due to it being calibrated out by the high-resolution U1 DAC. The effective number of bits (ENB) for a 4–20mA current-loop transmitter can be calculated as:

$$ENB = \frac{\text{LOG}(20\text{mA DAC CODE} - 4\text{mA DAC CODE})}{\text{LOG}(2)}$$

and based on the data from Table 1, the ENB = 15.56 bits.

There are other sources of error that need to be addressed, such as ±25µV of V<sub>OS</sub> of the U2 op amp and the temperature coefficients of each component. The typical characterization data of the MAX5216LPT 4–20mA current-loop transmitter is presented in Figures 7–12. The loop current is measured by an Agilent-HP3458A DVM as voltage drop across the loop load/sense resistor of 249Ω.

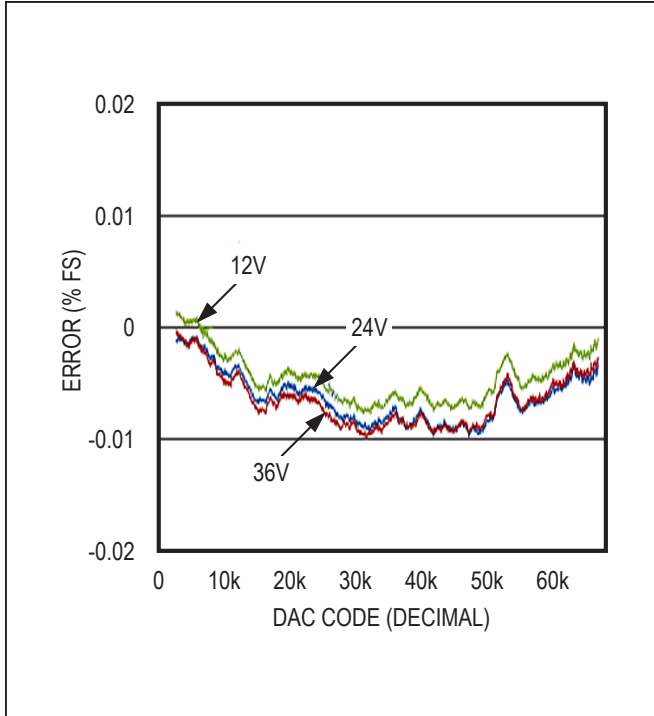

Figure 7. Transmitter Error at +25°C

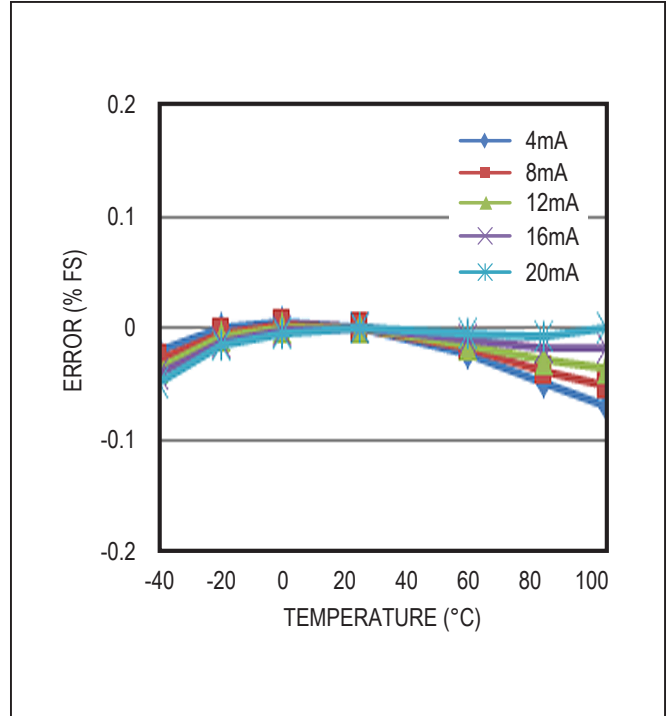

Figure 9. Transmitter Error Change vs. Temperature with 12V Loop Supply

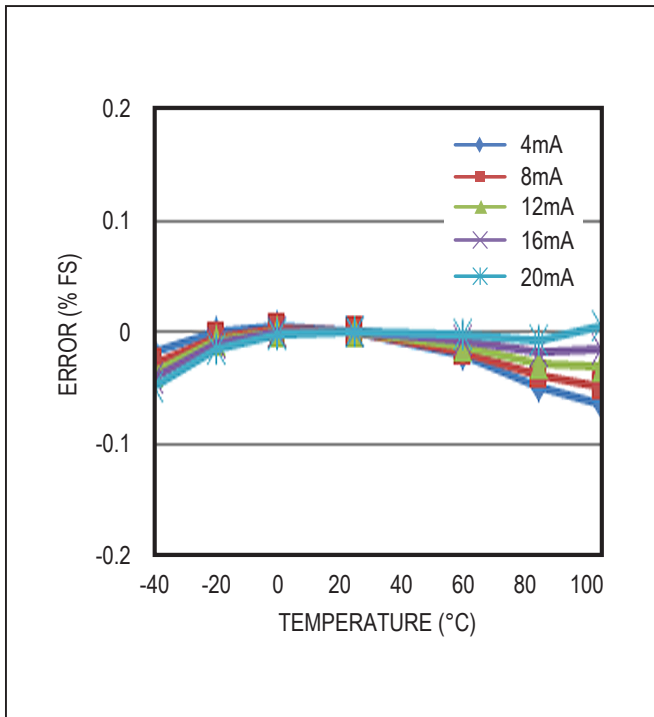

Figure 8. Transmitter Error Change vs. Temperature with 24V Loop Supply

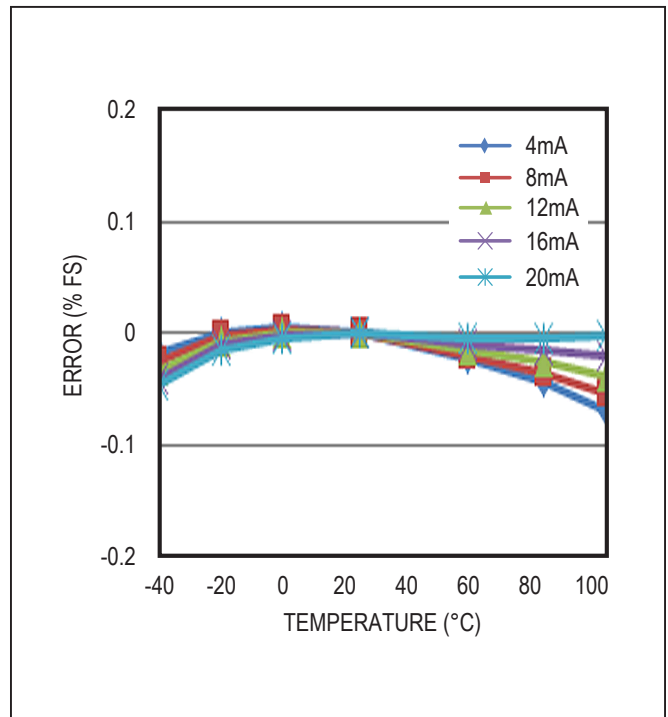

Figure 10. Transmitter Error Change vs. Temperature with 36V Loop Supply

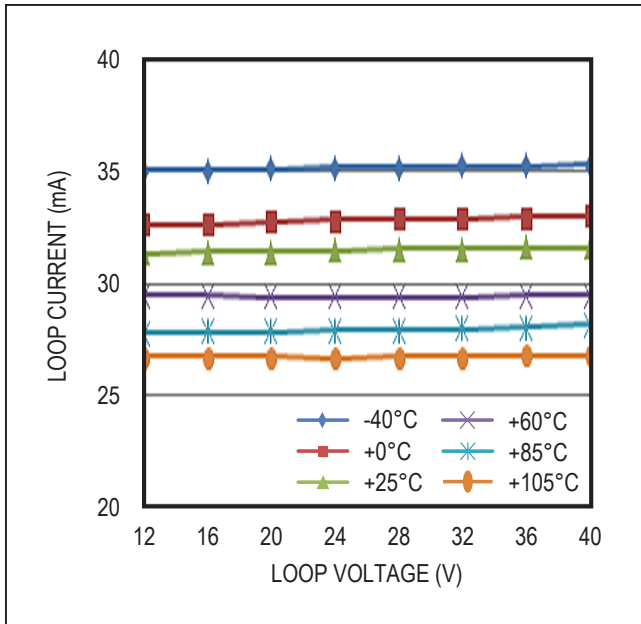

Figure 11. Current Limit vs. Loop Voltage Supply

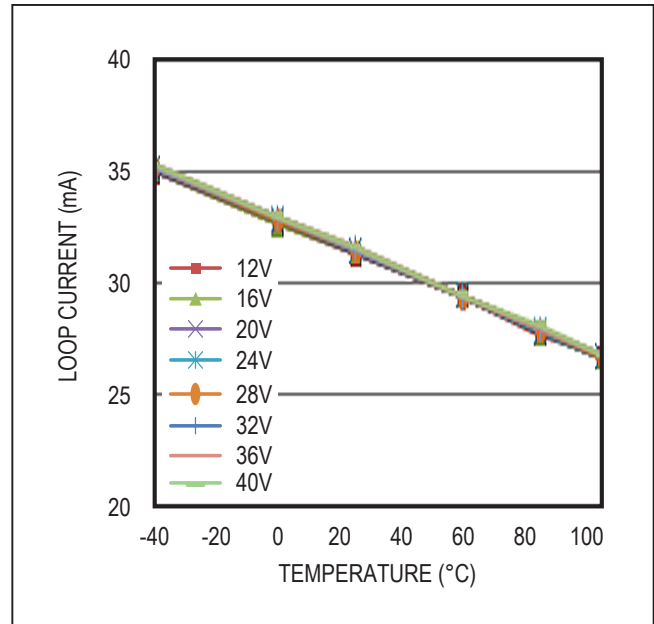

Figure 12. Current Limit vs. Temperature

**MAX5216LPT Extended Features**

- 1) The board quiescent current is about 200µA (typ), which allows consuming up to 3.4mA by smart sensor. This current can be measured by a DVM connected across R7 while the J7 shunt is removed and U1 code is 0. Removing the J7 shunt eliminates 4mA offset current.
- 2) The 4mA offset current is independent from the actual current consumption by the smart sensor. An additional 1mA can be added by placing the J11 shunt, but the 4mA offset current (400mV across R7) does not change.
- 3) The current-limiting condition can be forced by placing the J8 shunt from the default position of 1-2 to position 2-3.
- 4) The board can be evaluated over the full SPI bus speed range with an external SPI host controller. To do so, the following board modifications must be made:
  - Remove the J3–J5 shunts (see Figure 10 for component placement).
  - Connect the SPI lines, CS, SCLK, MOSI, and VGND from TP5–TP8 to the external host controller. Ensure that the input voltage (V<sub>IH</sub>) is within the spec limit and matches 3.3V level. Note that digital isolation might be necessary for proper operation.
  - Send a command to the DAC.

- 5) The board is ready for HART interface to exchange data over 4–20mA current loop using the DS8500-KIT HART modem. Simply connect the FSKOUT pin (P2.3) of the modem to TP10, modem's GND (P2.5) to TP11, and FSKIN pin (P2.2) to TP12. Connect the P2.1 pin (V33) of the DS8500 EV kit board to TP4 (3.3V). Use the digital interface to send and receive the data. Refer to the DS8500 IC data sheet and the DS8500-EV kit data sheet for more info.

The microcontroller on the EV kit board can also be programmed with custom firmware through the J2 JTAG connector (see Table 2).

**Table 2. JTAG Connector Description (J2)**

PIN	LABEL	FUNCTION
1	TCK	Test clock
2	GND	Digital ground
3	TDO	Test data output
4	N.C.	No connect
5	TMS	Test mode select
6	RST	Reset
7	N.C.	No connection
8	+5V	+5V from the JTAG debug adapter
9	TDI	Test data input
10	GND	Digital ground

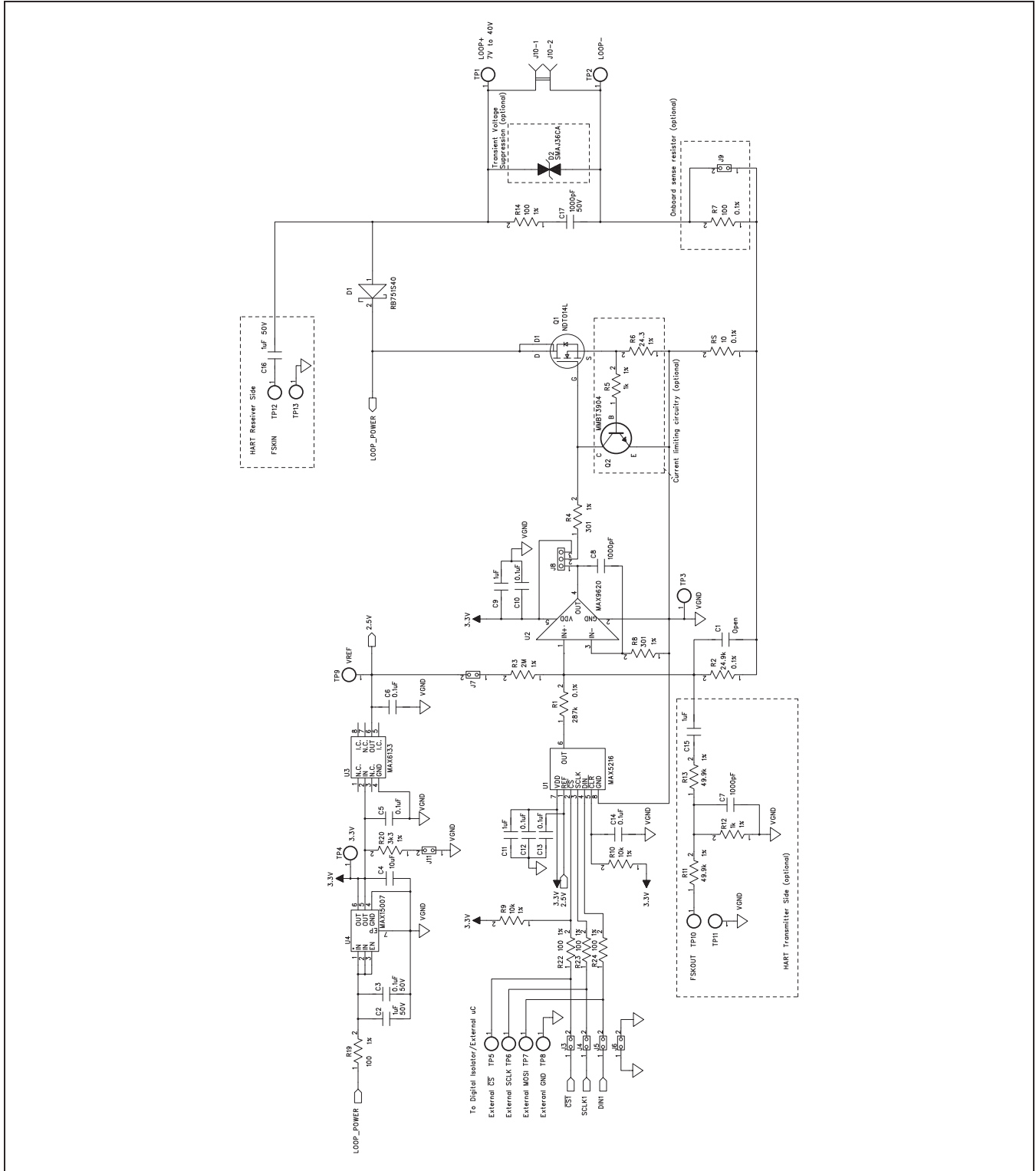

Figure 13a. MAX5216LPT EV Kit Schematic (Sheet 1 of 2)

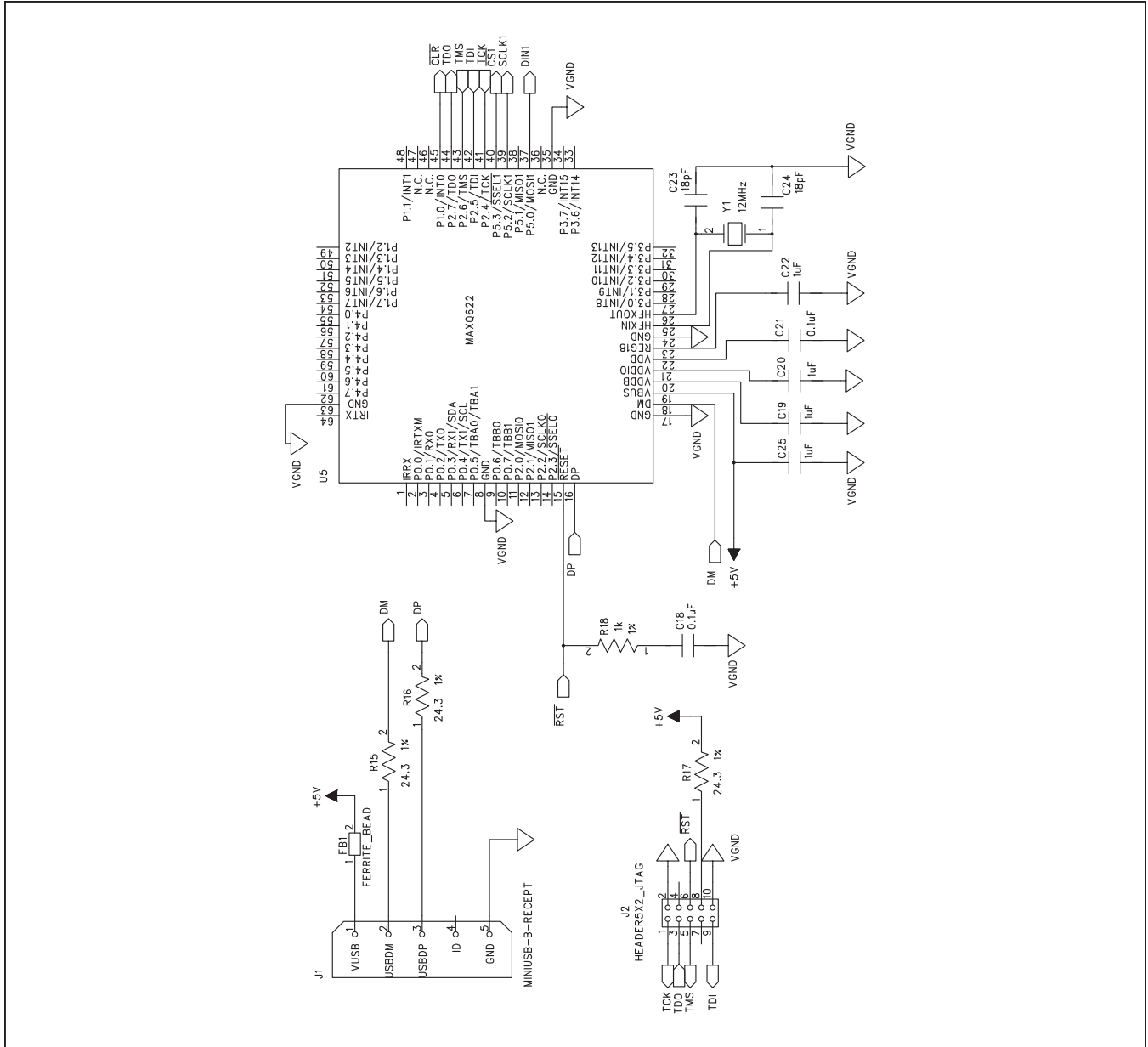

Figure 13b. MAX5216LPT EV Kit Schematic (Sheet 2 of 2)

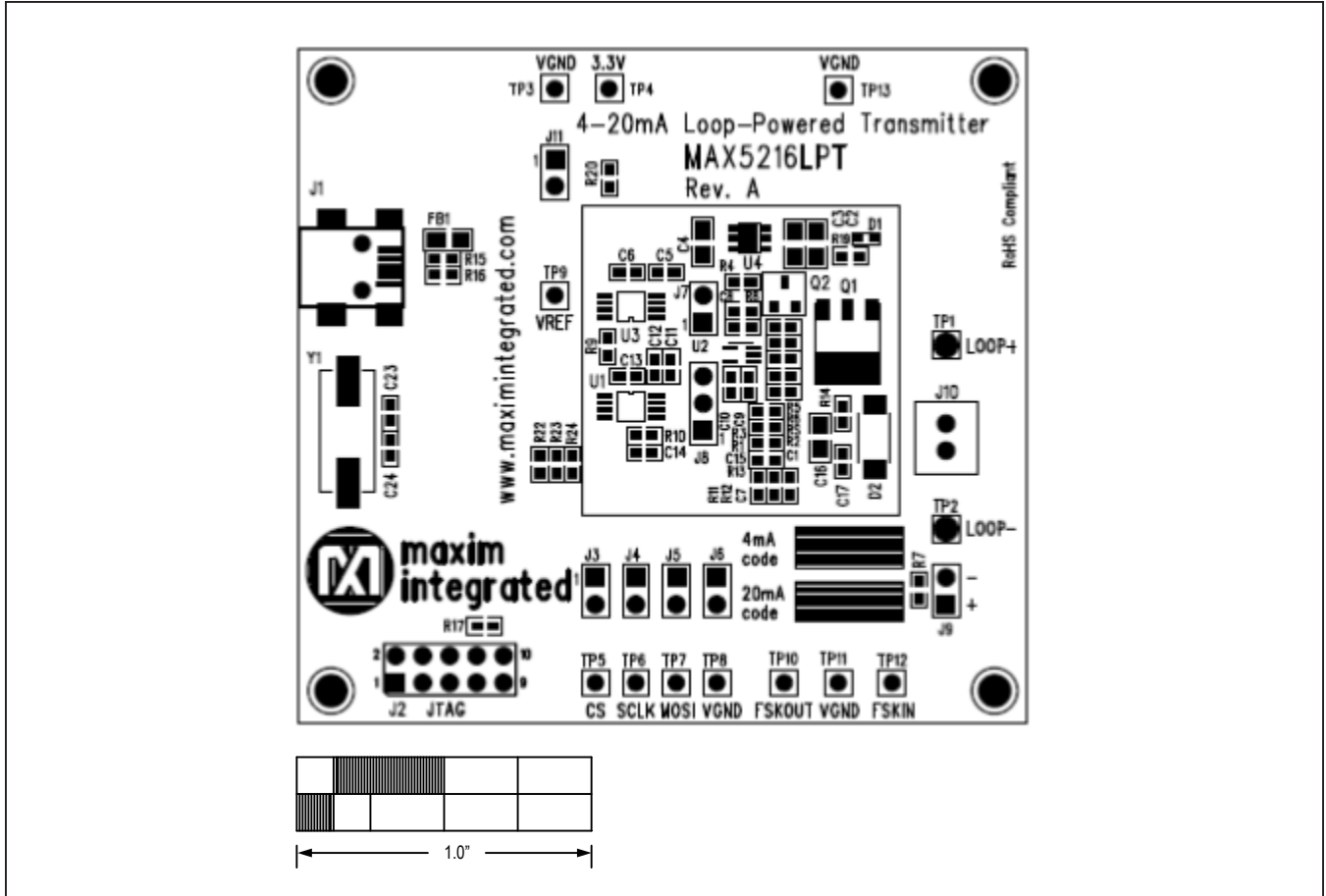

Figure 14. MAX5216LPT EV Kit Component Placement Guide—Assembly Drawing Top

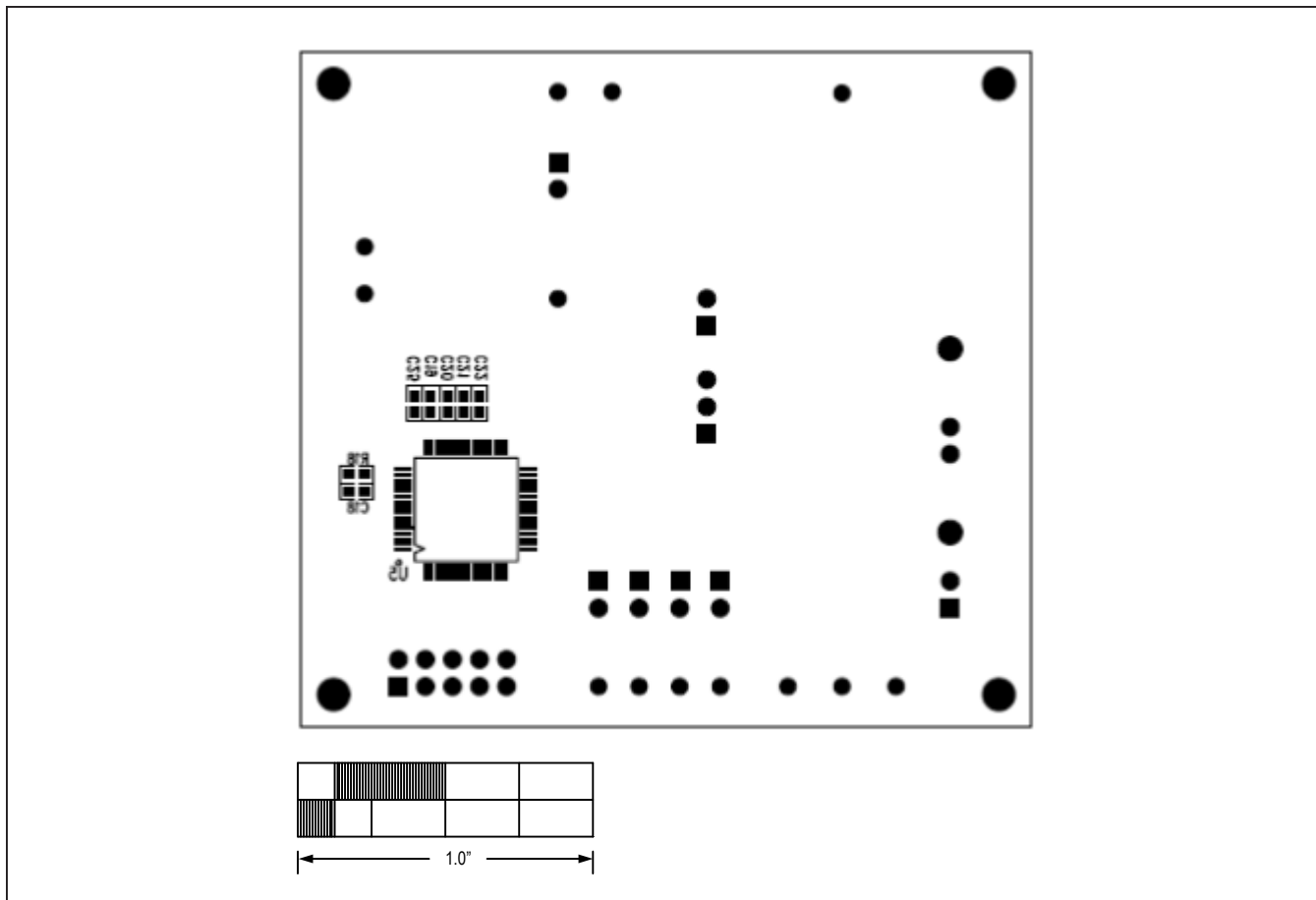

Figure 15. MAX5216LPT EV Kit Component Placement Guide—Assembly Drawing Bottom

Contact the Support Center at <https://support.maximintegrated.com/designdesk/index.mvp> for full layout drawings and/or a Gerber file for the MAX5216LPTEVKIT board.

---

## MAX5216LPT Evaluation Kit

Evaluates: Reference Design of  
4–20mA Loop-Powered Transmitter

### Ordering Information

PART	TYPE
MAX5216LPT#	EV Kit

#Denotes RoHS compliant.

### Revision History

REVISION NUMBER	REVISION DATE	DESCRIPTION	PAGES CHANGED
0	5/13	Initial release	—

For pricing, delivery, and ordering information, please contact Maxim Direct at 1-888-629-4642, or visit Maxim Integrated's website at [www.maximintegrated.com](http://www.maximintegrated.com).

*Maxim Integrated cannot assume responsibility for use of any circuitry other than circuitry entirely embodied in a Maxim Integrated product. No circuit patent licenses are implied. Maxim Integrated reserves the right to change the circuitry and specifications without notice at any time.*