



# GBJ/KBJ35005 thru GBJ/KBJ3510

## 35.0 A Single-Phase Silicon Bridge Rectifier Rectifier Reverse Voltage 50 to 1000V

### Features

- Ideal for printed circuit board mounting
- This series is UL listed under the Recognized Component Index, file number E142814
- The plastic material used carries Underwriters Laboratory flammability recognition 94V-0
- Built-in printed circuit board stand-offs
- High case dielectric strength
- High temperature soldering guaranteed 260°C/5 seconds at 5 lbs (2.3kg) tension

### Mechanical Data

Case: Reliable low cost construction utilizing molded plastic technique

Terminals: Plated leads solderable per MIL-STD-202, Method 208

Mounting Position: Any

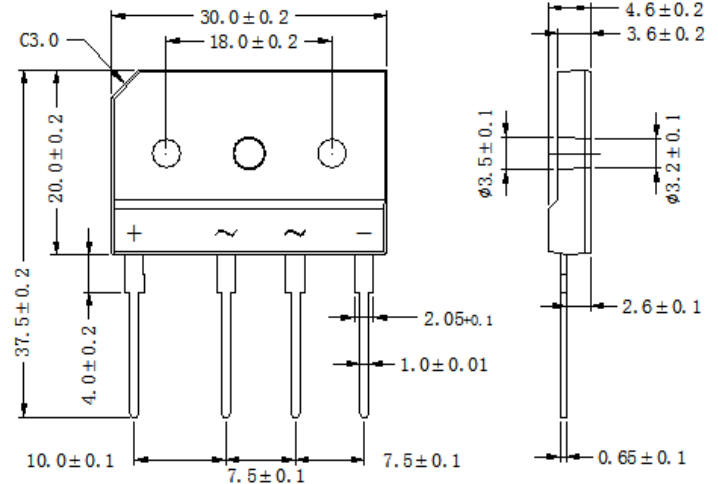

Dimensions in inches and (millimeters)

### Maximum Ratings & Thermal Characteristics

Rating at 25°C ambient temperature unless otherwise specified, Resistive or Inductive load, 60 Hz.  
For Capacitive load derate current by 20%.

CHARACTERISTICS	SYMBOL	GBJ/KBJ	GBJ/KBJ	GBJ/KBJ	GBJ/KBJ	GBJ/KBJ	GBJ/KBJ	GBJ/KBJ	UNIT	
		35005	3501	3502	3504	3506	3508	3510		
Maximum Recurrent Peak Reverse Voltage	V <sub>RRM</sub>	50	100	200	400	600	800	1000	V	
Maximum RMS Voltage	V <sub>RMS</sub>	30	70	140	280	420	560	700	V	
Maximum DC Blocking Voltage	V <sub>DC</sub>	50	100	200	400	600	800	1000	V	
Maximum Average Forward (with heatsink Note 2) Rectified Current @ T <sub>c</sub> =100°C (without heatsink)	I <sub>(AV)</sub>	35.0							3.5	A
Peak Forward Surge Current 8.3ms Single Half Sine-Wave Super Imposed on Rated Load (JEDEC Method)	I <sub>FSM</sub>	400								A
Maximum Forward Voltage at 10.0A DC	V <sub>F</sub>	1.1								V
Maximum DC Reverse Current @ T <sub>J</sub> =25°C at Rated DC Blocking Voltage @ T <sub>J</sub> =125°C	I <sub>R</sub>	10							500	uA
Typical Thermal Resistance (Note2)	R <sub>θJC</sub>	1.5								°C/W
Operating Temperature Range	T <sub>J</sub>	-55 to +150								°C
Storage Temperature Range	T <sub>STG</sub>	-55 to +150								°C

NOTES: 1.Measured at 1.0MHz and applied reverse voltage of 4.0V DC.

2.Device mounted on 300mm\*300mm\*1.6mm cu plate heatsink.

# Rating and Characteristic Curves ( $T_A=25^{\circ}\text{C}$ Unless otherwise noted )

## GBJ/KBJ35005 thru GBJ/KBJ3510

FIG.1-FORWARD CURRENT DERATING CURVE

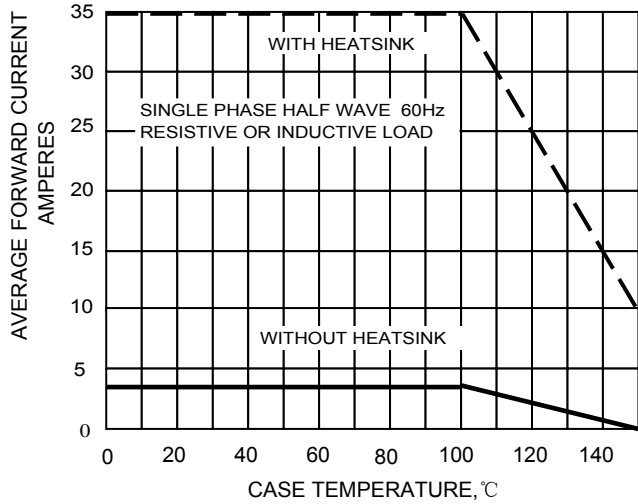

FIG.2-MAXMUN NON-REPETITIVE SURGE CURRENT

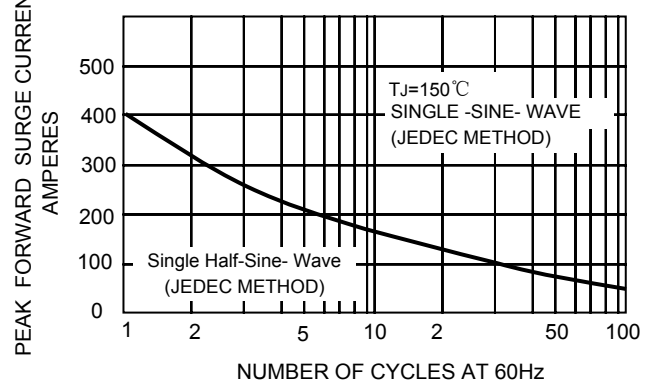

FIG.3-TYPICAL JUNCTION CAPACITANCE

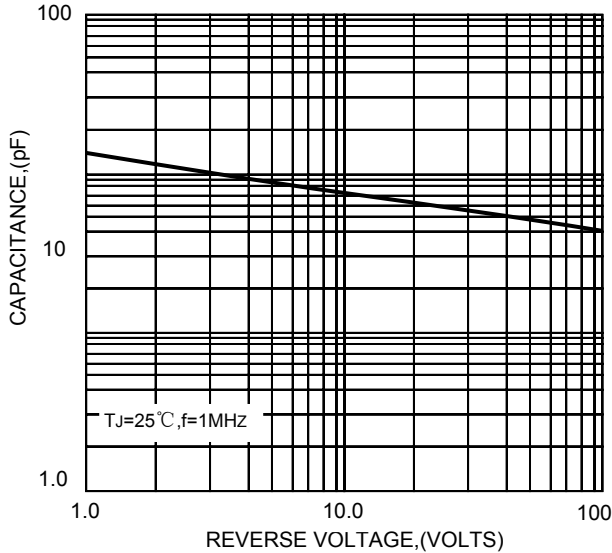

FIG.4-TYPICAL FORWARD CHARACTERISTICS

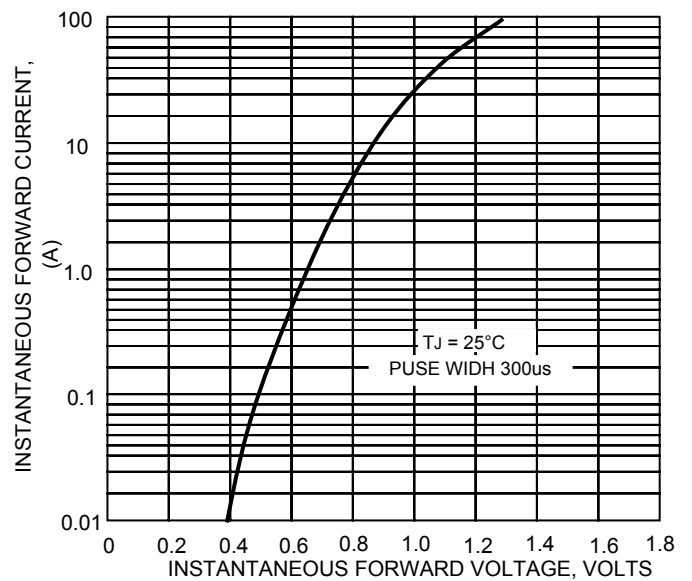

FIG.5-TYPICAL REVERSE

