

# HL-G1 SERIES

Related Information

- General terms and conditions..... F-3
- Selection guide ..... P.1021~
- Glossary of terms / General precautions ..... P.1587 / P.1595
- About laser beam..... P.1593~

- FIBER SENSORS
- LASER SENSORS
- PHOTOELECTRIC SENSORS
- MICRO PHOTOELECTRIC SENSORS
- AREA SENSORS
- SAFETY LIGHT CURTAINS / SAFETY COMPONENTS
- PRESSURE / FLOW SENSORS
- INDUCTIVE PROXIMITY SENSORS
- PARTICULAR USE SENSORS
- SENSOR OPTIONS
- SIMPLE WIRE-SAVING UNITS
- WIRE-SAVING SYSTEMS
- MEASUREMENT SENSORS
- STATIC CONTROL DEVICES
- LASER MARKERS
- PLC
- HUMAN MACHINE INTERFACES
- ENERGY MANAGEMENT SOLUTIONS
- FA COMPONENTS
- MACHINE VISION SYSTEMS
- UV CURING SYSTEMS

- Selection Guide
- Laser Displacement
- Magnetic Displacement
- Contact Displacement
- Collimated Beam Sensors
- Metal-sheet Double-feed Detection
- Digital Panel Controller
- Other Products

- HL-G1
- HL-C2
- HL-D3



[panasonic.net/id/pidsx/global](http://panasonic.net/id/pidsx/global)



**Warning:** This product is classified as a Class 2 (specular reflection type: Class 1) Laser Product in IEC / JIS standards and in FDA\* regulations. Do not look at the laser beam directly or through optical system such as a lens.

\*This product complies with 21 CFR 1040.10 and 1040.11 Laser Notice No. 50, dated June 24, 2007, issued by CDRH (Center for Devices and Radiological Health) under the FDA (Food and Drug Administration).

## Introducing the new standard in CMOS laser displacement sensors

This single instrument delivers both high-precision measurement and computer-driven data analysis

### High resolution of 0.5 μm 0.020 mil

Thanks to high-precision measurement at a resolution of 0.5 μm 0.020 mil and an LED digital display that provides exceptional ease of use, the HL-G1 series will see use in a variety of applications on production lines worldwide.

A total of 8 models accommodate a variety of applications



Diffuse reflection type	Specular reflection type
<b>HL-G103</b> □	<b>HL-G103A</b> □
Measurement range: 30 ±4 mm 1.181 ±0.157 in	Measurement range: 26.3 ±2 mm 1.035 ±0.079 in
Resolution: 0.5 μm 0.020 mil	Resolution: 0.5 μm 0.020 mil
Linearity: ±0.1 % F.S.	Linearity: ±0.2 % F.S.
Beam diameter: 0.1 × 0.1 mm 0.004 × 0.004 in	Beam diameter: 0.1 × 0.1 mm 0.004 × 0.004 in

Diffuse reflection type	Specular reflection type
<b>HL-G105</b> □	<b>HL-G105A</b> □
Measurement range: 50 ±10mm 1.969 ±0.394 in	Measurement range: 47.3 ±5 mm 1.862 ±0.197 in
Resolution: 1.5 μm 0.059 mil	Resolution: 1.5 μm 0.059 mil
Linearity: ±0.1 % F.S.	Linearity: ±0.2 % F.S.
Beam diameter: 0.5 × 1.0 mm 0.020 × 0.039 in	Beam diameter: 0.1 × 0.1 mm 0.004 × 0.004 in

Diffuse reflection type	Specular reflection type
<b>HL-G108</b> □	<b>HL-G108A</b> □
Measurement range: 85 ±20 mm 3.346 ±0.787 in	Measurement range: 82.9 ±10 mm 3.264 ±0.394 in
Resolution: 2.5 μm 0.098 mil	Resolution: 2.5 μm 0.098 mil
Linearity: ±0.1 % F.S.	Linearity: ±0.2 % F.S.
Beam diameter: 0.75 × 1.25 mm 0.030 × 0.049 in	Beam diameter: 0.2 × 0.2 mm 0.008 × 0.008 in

Diffuse reflection type
<b>HL-G112</b> □
Measurement range: 120 ±60 mm 4.724 ±2.362 in
Resolution: 8 μm 0.315 mil
Linearity: ±0.1 % F.S.
Beam diameter: 1.0 × 1.5 mm 0.039 × 0.059 in

Diffuse reflection type
<b>HL-G125</b> □
Measurement range: 250 ±150 mm 9.843 ±5.906 in
Resolution: 20 μm 0.787 mil
Linearity: ±0.3 % F.S.
Beam diameter: 1.75 × 3.5 mm 0.069 × 0.138 in

## Quick

Setup is fast and efficient by using the built-in digital display to set measurement parameters such as sampling cycle and output options.

## Compact

The HL-G1 series features a compact design despite its built-in controller and digital readout. Thanks to our miniaturization technology, it can easily be installed on robot arms and in confined spaces.

## Friendly

The HL-G1 series now features a user-friendly interface that offers improved ease of use when operating via computer software or HMI unit for more sophisticated operation and analysis.

**APPLICATIONS**

**Controlling the height of a dispenser nozzle**

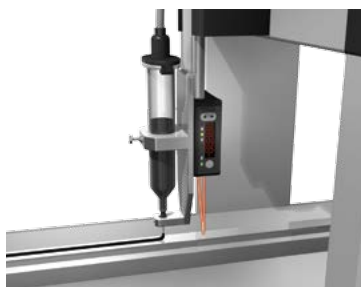

**Positioning of wafer**

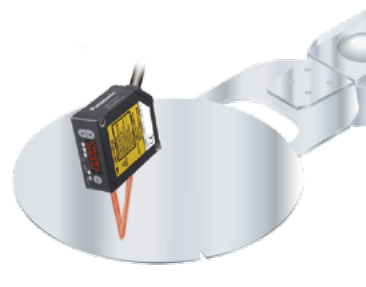

**Measuring the eccentricity of a metal shaft**



**Detection of circuit board warpage**

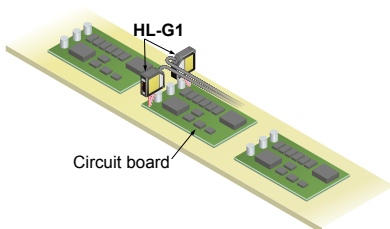

**Measurement of sheet thickness**

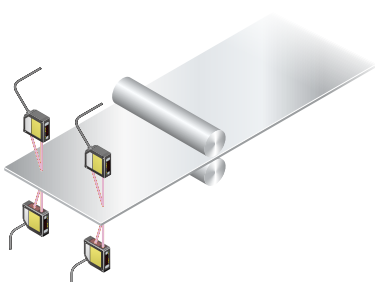

**Testing sheet slack**

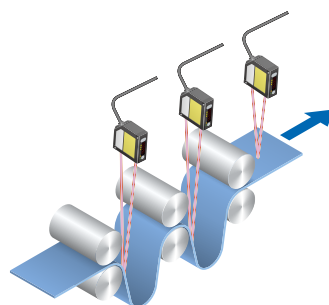

**BASIC PERFORMANCE**

**Easy input settings while looking at digital display**

The built-in digital display makes it easy to perform sensor setting while checking displacement values.

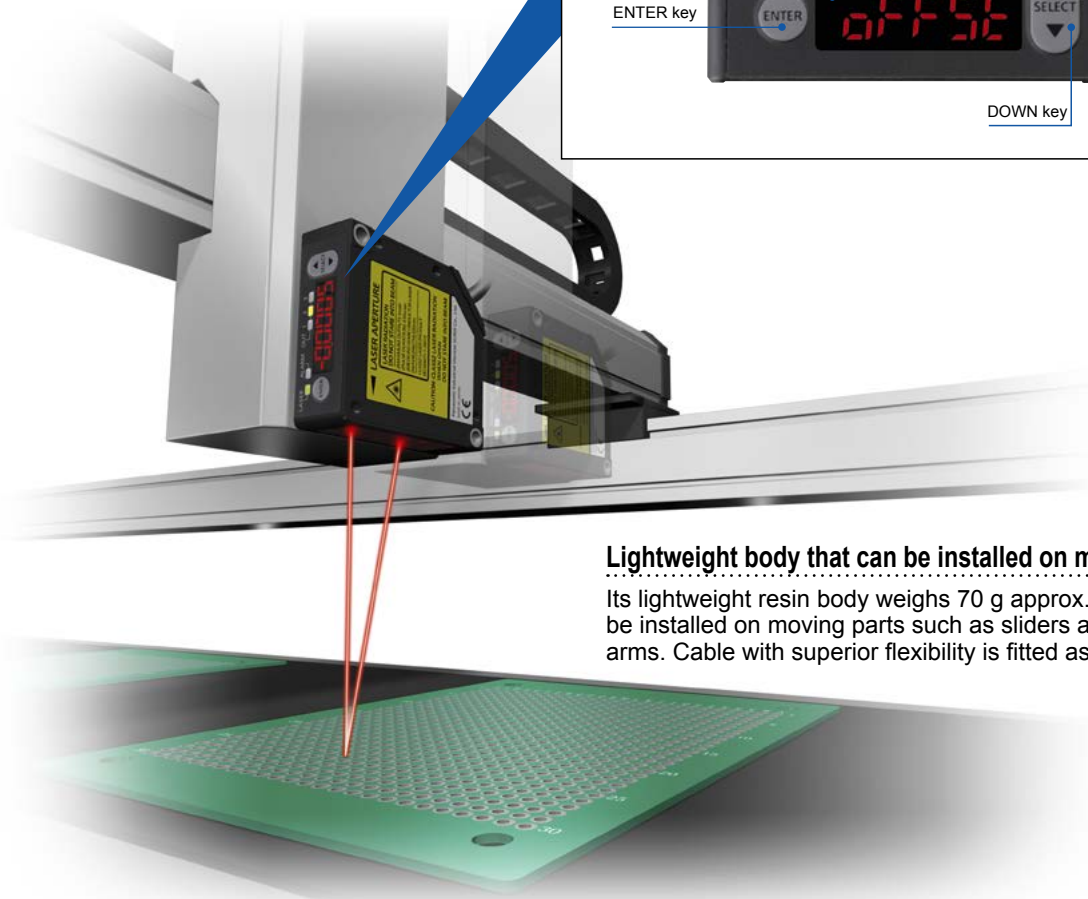
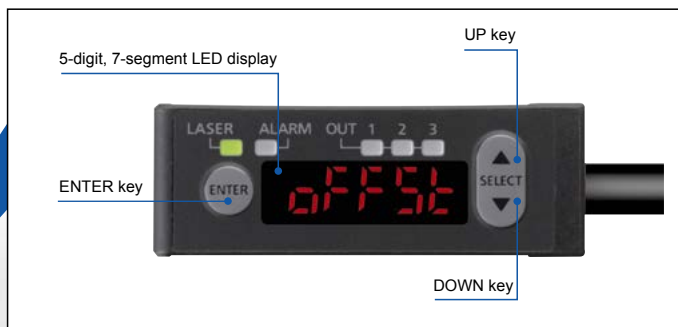

**Lightweight body that can be installed on movable parts**

Its lightweight resin body weighs 70 g approx., which can be installed on moving parts such as sliders and robot arms. Cable with superior flexibility is fitted as standard.

FIBER SENSORS

LASER SENSORS

PHOTOELECTRIC SENSORS

MICRO PHOTOELECTRIC SENSORS

AREA SENSORS

SAFETY LIGHT CURTAINS / SAFETY COMPONENTS

PRESSURE / FLOW SENSORS

INDUCTIVE PROXIMITY SENSORS

PARTICULAR USE SENSORS

SENSOR OPTIONS

SIMPLE WIRE-SAVING UNITS

WIRE-SAVING SYSTEMS

MEASUREMENT SENSORS

STATIC CONTROL DEVICES

LASER MARKERS

PLC

HUMAN MACHINE INTERFACES

ENERGY MANAGEMENT SOLUTIONS

FA COMPONENTS

MACHINE VISION SYSTEMS

UV CURING SYSTEMS

Selection Guide

Laser Displacement

Magnetic Displacement

Contact Displacement

Collimated Beam Sensors

Metal-sheet Double-feed Detection

Digital Panel Controller

Other Products

**HL-G1**

**HL-C2**

**HL-D3**

FIBER  
SENSORSLASER  
SENSORSPHOTOELECTRIC  
SENSORSMICRO  
PHOTOELECTRIC  
SENSORSAREA  
SENSORSSAFETY LIGHT  
CURTAINS /  
SAFETY COMPONENTSPRESSURE /  
FLOW  
SENSORSINDUCTIVE  
PROXIMITY  
SENSORSPARTICULAR  
USE SENSORSSENSOR  
OPTIONSSIMPLE  
WIRE-SAVING  
UNITSWIRE-SAVING  
SYSTEMSMEASUREMENT  
SENSORSSTATIC  
CONTROL  
DEVICESLASER  
MARKERS

PLC

HUMAN MACHINE  
INTERFACESENERGY  
MANAGEMENT  
SOLUTIONS

FA COMPONENTS

MACHINE VISION  
SYSTEMSUV CURING  
SYSTEMSSelection  
GuideLaser  
DisplacementMagnetic  
DisplacementContact  
DisplacementCollimated  
Beam SensorsMetal-sheet  
Double-feed DetectionDigital Panel  
Controller

Other Products

**HL-G1****HL-C2****HL-D3**

## Compact

Compact size despite the built-in controller and digital read out.



## Easy to embed in machines and production lines

Controller installation and mounting space is not required because controller function is included in sensor unit.

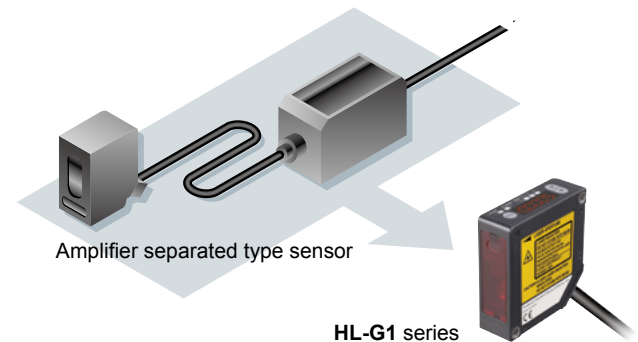

## IP67 protective enclosure protects from water and dust

Thanks to its IP67 protective enclosure, the **HL-G1** can be used in the presence of water and dust. Mounting holes are lined with metal sleeves, allowing the instrument to be tightened securely in place with up to 0.8 N·m of torque.



## FUNCTIONS

### Timing input and multi input

In addition to timing input select the desired input according to your application:

- Zero set on / off
- Reset
- Memory switching
- Laser control
- Teaching
- Saving

### Support for both NPN and PNP polarity **GLOBAL SUPPORT**

A single model number accommodates both NPN and PNP wiring polarity, reducing the number of model numbers that must be registered for maintenance purposes.

### Featuring 3 outputs and an analog 2 outputs

With three outputs, the **HL-G1** can be used to generate HI / GO / LOW judgment output or alarm output. The analog output can be used in both current and voltage modes.

### Memory switching function

Up to four groups of sensor settings can be stored for fast recall. Easy switching among setting groups allows smooth setup changes.

**HIGH FUNCTION TYPE (HL-G1□-S-J / HL-G1□-RS-J)**

The integrated communications interface lets the sensor communicate with upstream devices such as PLCs.

Sensors and other devices can be connected in a 1:1 manner using RS-422, or up to 16 **HL-G1** series sensors can be connected using RS-485, enabling them to return measured values in response to messages from the PLC. When using one of our PLCs\*, you can use the PLC's data write / read instructions (F145 and F146) to easily configure **HL-G1** series settings and acquire measurement output.

\* Supported PLCs from Panasonic Industrial Devices SUNX:  
**FP0R, FPΣ, FP-X**

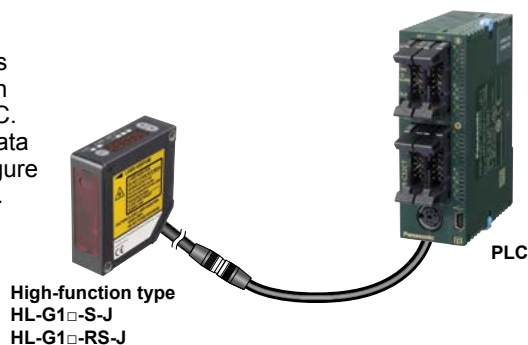
**Software tool for sensor configuration and evaluation (Free download available)**

In addition to configuring up to 16 sensors at once, this free tool makes it easy to gather data needed for analysis, such as received light waveform monitoring and data buffering. The interface language can be selected at the time of installation.

- **Data buffering**  
Stores and displays measurement data, which can be superimposed on previously recorded data for easy comparison and analysis.
- **Received light waveform display**  
Displays the amount of light received by cell from light-receiving element.
- **Measured value display**  
Displays measured values as well as the output state for each terminal.

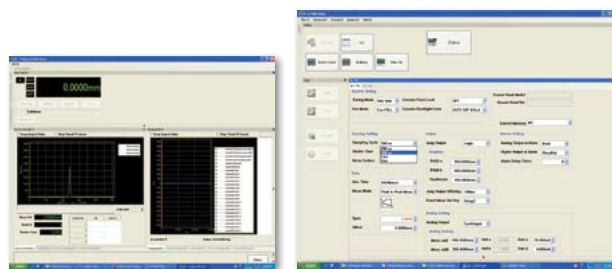
**HMI screen (Free download available)**

The **GT02 / GT12** series HMI can be used in combination with the **HL-G1** to allow easy confirmation of sensor status and configuration of sensor settings from a remote location. Japanese, English, Chinese, and Korean are supported. For more information about the **GT02 / GT12** series, visit our website.

**Select from the following HMI operator panels:**

Power supply: 24 V  
Communication port: RS-422 / RS-485

- AIG02GQ14D
- AIG02MQ15D
- AIG12GQ14D / AIG12GQ15D
- AIG12MQ14D / AIG12MQ15D

**Multilingualization****GLOBAL SUPPORT**

Software tool and HMI screen data support not only Japanese and English, but also Chinese and Korean, providing a new level of support for devices and equipment in use worldwide.

Software is available for download.

Sensor configuration and evaluation software tool, HMI screen data, function blocks, etc.

**Terms of use**

Panasonic Industrial Devices SUNX offers no warranty for this software and is not liable for any loss or damage suffered as a result of its use or operation, whether direct, indirect, incidental, consequential, or unforeseen.

FIBER SENSORS

LASER SENSORS

PHOTOELECTRIC SENSORS

MICRO PHOTOELECTRIC SENSORS

AREA SENSORS

SAFETY LIGHT CURTAINS / SAFETY COMPONENTS

PRESSURE / FLOW SENSORS

INDUCTIVE PROXIMITY SENSORS

PARTICULAR USE SENSORS

SENSOR OPTIONS

SIMPLE WIRE-SAVING UNITS

WIRE-SAVING SYSTEMS

MEASUREMENT SENSORS

STATIC CONTROL DEVICES

LASER MARKERS

PLC

HUMAN MACHINE INTERFACES

ENERGY MANAGEMENT SOLUTIONS

FA COMPONENTS

MACHINE VISION SYSTEMS

UV CURING SYSTEMS

Selection Guide

Laser Displacement

Magnetic Displacement

Contact Displacement

Collimated Beam Sensors

Metal-sheet Double-feed Detection

Digital Panel Controller

Other Products

**HL-G1****HL-C2****HL-D3**

**ORDER GUIDE**

When using the high function type sensor, please order the extension cable separately.

Type	Appearance	Measurement center distance and measuring range	Resolution	Beam diameter	Model No.	Laser class			
Diffuse reflection type	 <p>Standard type</p>	30 ±4 mm 1.181 ±0.157 in	0.5 μm 0.020 mil	0.1 × 0.1 mm 0.004 × 0.004 in	HL-G103-A-C5	FDA / IEC: Class 2			
					HL-G103-S-J				
		50 ±10 mm 1.969 ±0.394 in	1.5 μm 0.059 mil	0.5 × 1 mm 0.020 × 0.039 in	HL-G105-A-C5				
					HL-G105-S-J				
		85 ±20 mm 3.346 ±0.787 in	2.5 μm 0.098 mil	0.75 × 1.25 mm 0.030 × 0.049 in	HL-G108-A-C5				
					HL-G108-S-J				
	 <p>High function type</p>	120 ±60 mm 4.724 ±2.362 in	8 μm 0.315 mil	1.0 × 1.5 mm 0.039 × 0.059 in	HL-G112-A-C5				
					HL-G112-S-J				
		250 ±150 mm 9.843 ±5.906 in	20 μm 0.787 mil	1.75 × 3.5 mm 0.069 × 0.138 in	HL-G125-A-C5				
					HL-G125-S-J				
		Specular reflection type	 <p>Standard type</p>	26.3 ±2 mm 1.035 ±0.079 in	0.5 μm 0.020 mil		0.1 × 0.1 mm 0.004 × 0.004 in	HL-G103A-RA-C5	FDA / IEC: Class 1
								HL-G103A-RS-J	
47.3 ±5 mm 1.862 ±0.197 in	1.5 μm 0.059 mil			HL-G105A-RA-C5					
			HL-G105A-RS-J						
 <p>High function type</p>	82.9 ±10 mm 3.264 ±0.394 in		2.5 μm 0.098 mil	0.2 × 0.2 mm 0.008 × 0.008 in	HL-G108A-RA-C5				
					HL-G108A-RS-J				

Note: High function type have communication interfaces (RS-422 / RS-485) and a cable with connector.

**OPTIONS**

When using the high function type sensor, please order the extension cable separately.

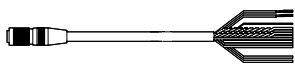
Type	Appearance	Model No.	Description
Extension cable (for high function type)		HL-G1CCJ2	Length: 2 m 6.562 ft, Weight: 130 g approx.
		HL-G1CCJ5	Length: 5 m 16.404 ft, Weight: 320 g approx.
		HL-G1CCJ10	Length: 10 m 32.808 ft, Weight: 630 g approx.
		HL-G1CCJ20	Length: 20 m 65.617 ft, Weight: 1,300 g approx.
			14-core cabtyre cable with connector on one side

- FIBER SENSORS
- LASER SENSORS
- PHOTO-ELECTRIC SENSORS
- MICRO PHOTO-ELECTRIC SENSORS
- AREA SENSORS
- SAFETY LIGHT CURTAINS / SAFETY COMPONENTS
- PRESSURE / FLOW SENSORS
- INDUCTIVE PROXIMITY SENSORS
- PARTICULAR USE SENSORS
- SENSOR OPTIONS
- SIMPLE WIRE-SAVING UNITS
- WIRE-SAVING SYSTEMS
- MEASURE-HEAT SENSORS
- STATIC CONTROL DEVICES
- LASER MARKERS
- PLC
- HUMAN MACHINE INTERFACES
- ENERGY MANAGEMENT SOLUTIONS
- FA COMPONENTS
- MACHINE VISION SYSTEMS
- UV CURING SYSTEMS
- Selection Guide
- Laser Displacement
- Magnetic Displacement
- Contact Displacement
- Collimated Beam Sensors
- Metal-sheet Double-feed Detection
- Digital Panel Controller
- Other Products

- HL-G1
- HL-C2
- HL-D3

**OPERATING ENVIRONMENT OF SOFTWARE TOOL**

Operating environment				
OS	OS	32-bit / 64-bit	Edition	Service Pack
	Microsoft® Windows® 7	32-bit / 64-bit	Professional	—
	Microsoft® Windows® 8		Pro	
	Microsoft® Windows® 10			
CPU	2 GHz or more			
Graphics	SXGA (1,280 × 1,024 full colors) or more			
Memory	2 GB or more			
Hard disk	Free space 100 MB or more			
USB interface	USB 2.0 full speed (USB 1.1 compatible)			

Notes: 1) This software accommodates below language. You can select the language when installing.

Japanese, English, Korean, Chinese

2) Microsoft Windows is trademark or registered trademark of Microsoft Corporation in the United States and other countries.

**INFORMATION OF INTERFACE CONVERTER**

The communications interface converter of **HL-G1** series is RS-422 or RS-485. Use the HMI operator panel **GT02** or **GT12** (through mode) or the following interface converter when using the tool software **HL-G1SMI** and connecting to PC by USB.

<p>LINEEYE CO., LTD.  Interface converter (USB to RS-422/485) SI-35USB  Website: <a href="http://www.lineeye.com">http://www.lineeye.com</a></p>
--

FIBER  
SENSORSLASER  
SENSORSPHOTO-  
ELECTRIC  
SENSORSMICRO  
PHOTO-  
ELECTRIC  
SENSORSAREA  
SENSORSSAFETY LIGHT  
CURTAINS/  
SAFETY  
COMPONENTSPRESSURE /  
FLOW  
SENSORSINDUCTIVE  
PROXIMITY  
SENSORSPARTICULAR  
USE  
SENSORSSENSOR  
OPTIONSSIMPLE  
WIRE-SAVING  
UNITSWIRE-SAVING  
SYSTEMSMEASURE-  
MENT  
SENSORSSTATIC  
CONTROL  
DEVICESLASER  
MARKERS

PLC

HUMAN  
MACHINE  
INTERFACESENERGY  
MANAGEMENT  
SOLUTIONSFA  
COMPONENTSMACHINE  
VISION  
SYSTEMSUV  
CURING  
SYSTEMSSelection  
GuideLaser  
DisplacementMagnetic  
DisplacementContact  
DisplacementCollimated  
Beam  
SensorsMetal-sheet  
Double-feed  
DetectionDigital Panel  
ControllerOther  
Products**HL-G1****HL-C2****HL-D3**

## SPECIFICATIONS

Item	Type	Diffuse reflection type					Specular reflection type		
		Standard type	HL-G103-A-C5	HL-G105-A-C5	HL-G108-A-C5	HL-G112-A-C5	HL-G125-A-C5	HL-G103A-RA-C5	HL-G105A-RA-C5
	High function type	HL-G103-S-J	HL-G105-S-J	HL-G108-S-J	HL-G112-S-J	HL-G125-S-J	HL-G103A-RS-J	HL-G105A-RS-J	HL-G108A-RS-J
CE marking directive compliance		EMC Directive, RoHS Directive							
Measurement center distance		30 mm 1.181 in	50 mm 1.969 in	85 mm 3.346 in	120 mm 4.724 in	250 mm 9.843 in	26.3 mm 1.035 in	47.3 mm 1.862 in	82.9 mm 3.264 in
Measuring range		±4 mm ±0.157 in	±10 mm ±0.394 in	±20 mm ±0.787 in	±60 mm ±2.362 in	±150 mm ±5.906 in	±2 mm ±0.079 in	±5 mm ±0.197 in	±10 mm ±0.394 in
Resolution		0.5 μm 0.020 mil	1.5 μm 0.059 mil	2.5 μm 0.098 mil	8 μm 0.315 mil	20 μm 0.787 mil	0.5 μm 0.020 mil	1.5 μm 0.059 mil	2.5 μm 0.098 mil
Linearity		±0.1 % F.S.				±0.3 % F.S.	±0.2 % F.S.		
Temperature characteristics		±0.08 % F.S./°C							
Light source		Red semiconductor laser, Class 2 (Class 1 for specular reflection type) (IEC / JIS / FDA (Note 2), Laser Notice No. 50) Max. output: 1 mW (0.39mW for specular reflection type), Peak emission wavelength: 655 nm 0.026 m							
Beam diameter (Note 3)		0.1 × 0.1 mm 0.004 × 0.004 in	0.5 × 1.0 mm 0.020 × 0.039 in	0.75 × 1.25 mm 0.030 × 0.049 in	1.0 × 1.5 mm 0.039 × 0.059 in	1.75 × 3.5 mm 0.069 × 0.138 in	0.1 × 0.1 mm 0.004 × 0.004 in		0.2 × 0.2 mm 0.008 × 0.008 in
Receiving element		CMOS image sensor							
Supply voltage		24 V DC ±10 % including ripple 0.5 V (P-P)							
Current consumption		100 mA max.							
Sampling rate		200 μs, 500 μs, 1 ms, 2 ms							
Analog output	Voltage	Output range: 0 to 10.5 V (normal) / 11 V (at alarm), Output impedance: 100 Ω							
	Current	Output range: 3.2 to 20.8 mA (normal) / 21.6 mA (at alarm), Load impedance: 300 Ω or less							
Outputs (OUT 1, OUT 2, OUT 3)		Judgment output or alarm output (setting selectable) NPN open-collector transistor / PNP open-collector transistor (selectable)							
		<In case of using NPN output> • Maximum sink current: 50 mA • Applied voltage: 3 to 24 V DC (between output and 0 V) • Residual voltage: 2 V or less (at 50 mA of sink current)				<In case of using PNP output> • Maximum source current: 50 mA • Residual voltage: 2.8 V or less (at 50 mA of source current)			
Output operation		Open when the output is ON.							
Short circuit protection		Incorporated (automatic restoration)							
Output polarity setting input		NPN open collector output operates when 0 V is connected. PNP open collector output operates when 24 V DC is connected.							
Timing input		NPN output operates when 0 V is connected and NPN is set (depending on settings). PNP output operates when external power + is connected and PNP is set (depending on settings).							
Multi input		Zero set, zero set off, reset, memory switching, teaching, saving, and laser control according to the input time. • In case NPN output is selected, function varies according to the time 0 V is connected NPN. • In case PNP output is selected, function varies according to the time external power + is connected.							
Communications interface (high-function type only)		RS-422 or RS-485 (selectable) Baud rate: 9,600 / 19,200 / 38,400 / 115,200 / 230,400 / 460,800 / 921,600 bps, Data length 8 bits, stop bit length 1 bit, without parity check, BCC check, termination code: CR							
Indicator	Laser emission	Green LED (lights up during laser emission)							
	Alarm	Orange LED (lights up when this product cannot measure because of insufficient or excessive light intensity)							
	Output	Yellow LED × 3							
Digital display		Red LED 5.5 digit display							
Environmental resistance	Ambient altitude	2,000 m 6,561 ft or less							
	Pollution degree	2							
	Protection	IP67 (IEC)							
	Ambient temperature	-10 to +45 °C +14 to +113 °F (No dew condensation allowed), Storage: -20 to +60 °C -4 to +140 °F (No dew condensation allowed)							
	Ambient humidity	35 to 85 % RH, Storage: 35 to 85 % RH							
	Ambient illuminance	Incandescent light: 3,000 lx or less at the light-receiving face (Note 4)							
	Insulation resistance	20 MΩ, or more, with 250 V DC megger between all supply terminals connected together and enclosure							
	Voltage withstandability	1,000 V AC for one min. between all supply terminals connected together and enclosure							
	Vibration resistance	10 to 55 Hz (period: 1 min.) frequency, 1.5 mm 0.059 in double amplitude in X,Y and Z directions for two hours each							
	Shock resistance	500 m/s <sup>2</sup> acceleration (50 G approx.) in X,Y and Z directions three times each							
Material		Enclosure: PBT, Front cover: Acrylic, Cable: PVC							
Cable		Standard type: 0.1 mm <sup>2</sup> 10-core cabtyre cable, 5 m 16.404 ft long, high function type: 14-core cabtyre cable with connector, 0.5 m 1.640 ft long							
Cable extension		Extension up to total 20 m 65.617 ft is possible with optional cable (Cable for standard type cannot be extended).							
Weight	Standard type	Net weight: 70 g approx. (not including cable), 320 g approx. (including cable), gross weight: 380 g approx.							
	High function type	Net weight: 70 g approx. (not including cable), 110 g approx. (including cable), gross weight: 160 g approx.							
Accessory		Warning label: 1 set							

- Notes: 1) Where measurement conditions have not been specified precisely, the conditions used were as follows: supply voltage 24 V DC, ambient temperature +20 °C +68 °F, sampling rate 500 μs, average number of samples: 1024, measurement center distance, object measured is made of white ceramic (specular reflection type: an aluminum vapor deposition surface reflection mirror) and analog measurement values.
- 2) This product complies with 21 CFR 1040.10 and 1040.11 Laser Notice No. 50, dated June 24, 2007, issued by CDRH (Center for Devices and Radiological Health) under the FDA (Food and Drug Administration).
- 3) This beam diameter is the size at the measurement center distance. These values were defined by using 1/e<sup>2</sup> (13.5 %) of the center light intensity. The results may be affected if there is a slight leakage of light outside the normal spot diameter and if the periphery surrounding the sensing point has a higher reflectivity than the sensing point itself.
- 4) The fluctuation by ambient illuminance is ±0.1 % F.S. or less.

**I/O CIRCUIT AND WIRING DIAGRAMS**

**I/O circuit diagrams**

**When selecting NPN output**

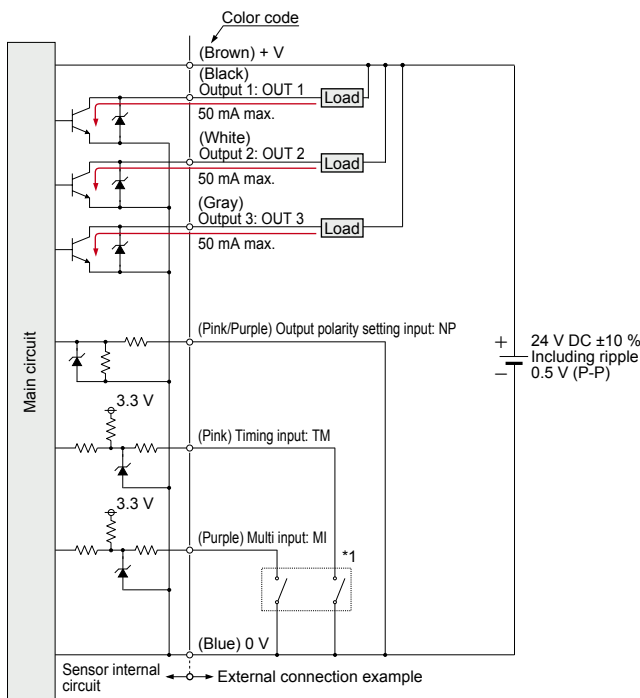

**When selecting PNP output**

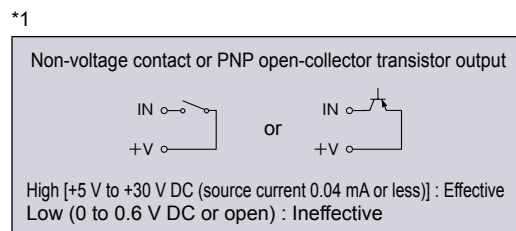
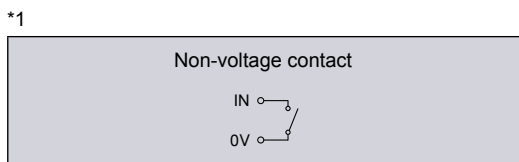
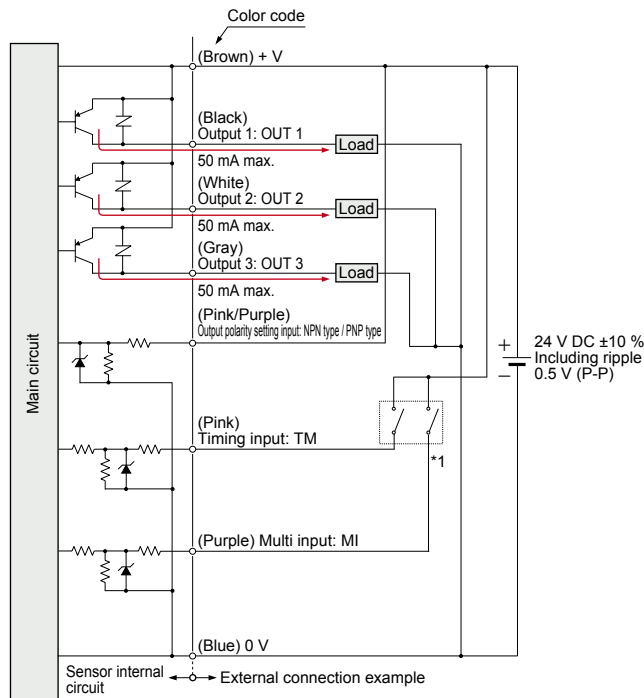

**Analog output (common in NPN output type and PNP output type)**

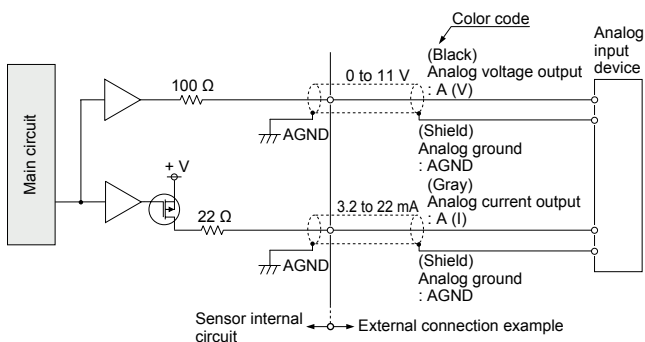

Notes: 1) Analog output is not equipped with the short-circuit protection. Do not short-circuit or apply voltage to them.  
2) Use shielded wires for analog outputs.

FIBER SENSORS

LASER SENSORS

PHOTO-ELECTRIC SENSORS

MICRO PHOTO-ELECTRIC SENSORS

AREA SENSORS

SAFETY LIGHT CURTAINS / SAFETY COMPONENTS

PRESSURE / FLOW SENSORS

INDUCTIVE PROXIMITY SENSORS

PARTICULAR USE SENSORS

SENSOR OPTIONS

SIMPLE WIRE-SAVING UNITS

WIRE-SAVING SYSTEMS

MEASURE-MENT SENSORS

STATIC CONTROL DEVICES

LASER MARKERS

PLC

HUMAN MACHINE INTERFACES

ENERGY MANAGEMENT SOLUTIONS

FA COMPONENTS

MACHINE VISION SYSTEMS

UV CURING SYSTEMS

Selection Guide

Laser Displacement

Magnetic Displacement

Contact Displacement

Collimated Beam Sensors

Metal-sheet Double-feed Detection

Digital Panel Controller

Other Products

**HL-G1**

**HL-C2**

**HL-D3**



- FIBER SENSORS
- LASER SENSORS
- PHOTO-ELECTRIC SENSORS
- MICRO PHOTO-ELECTRIC SENSORS
- AREA SENSORS
- SAFETY LIGHT CURTAINS / SAFETY COMPONENTS
- PRESSURE / FLOW SENSORS
- INDUCTIVE PROXIMITY SENSORS
- PARTICULAR USE SENSORS
- SENSOR OPTIONS
- SIMPLE WIRE-SAVING UNITS
- WIRE-SAVING SYSTEMS
- MEASURE-NEXT SENSORS
- STATIC CONTROL DEVICES
- LASER MARKERS
- PLC
- HUMAN MACHINE INTERFACES
- ENERGY MANAGEMENT SOLUTIONS
- FA COMPONENTS
- MACHINE VISION SYSTEMS
- UV CURING SYSTEMS
- Selection Guide
- Laser Displacement
- Magnetic Displacement
- Contact Displacement
- Collimated Beam Sensors
- Metal-sheet Double-feed Detection
- Digital Panel Controller
- Other Products
- HL-G1**
- HL-C2
- HL-D3

## I/O CIRCUIT AND WIRING DIAGRAMS

### Communication specifications (High function type)

Communication method	RS-422	RS-485
		Full duplex
Synchronization method	Asynchronous communication method	
Transmission code	ASC II	
Baud rate	9,600 / 19,200 / 38,400 / 115,200 / 230,400 / 460,800 / 921,600 bps	
Data length	8 bits	
Stop bit length	1 bit	
Parity check	None	
BCC	Yes	
Termination code	CR	

The **HL-G1** can be connected to upper devices of RS-422/485.  
When upper device sends the request command, the **HL-G1** series send the response command.

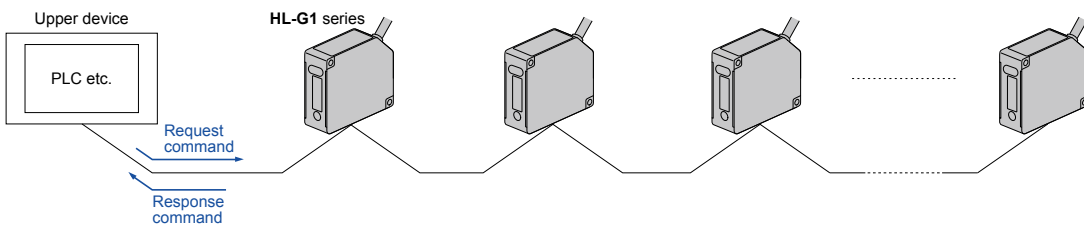

### RS-422 1-to-1 connection

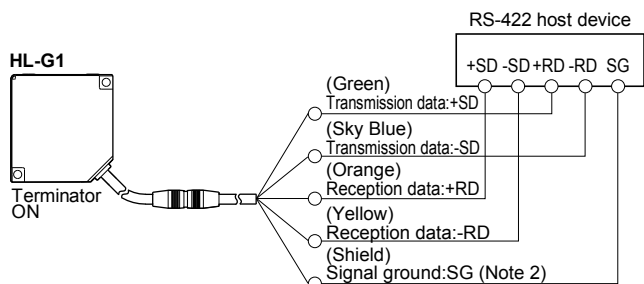

- Notes:
- 1) The transmission data cable and reception data cable are both twisted-pair cables.
  - 2) The shield is connected to the 0 V side of the power supply line inside the sensor.
  - 3) Be sure to connect the signal ground.
  - 4) The sensor is of non-isolated type. Make sure that the potential difference between the sensor and RS-422 connecting device does not exceed 4 V. A difference in potential in excess may cause the connecting device or the sensor to malfunction.

### RS-485 1-to-N connection

- Connectable up to 16 units.
- Please set the prefix with no duplication.

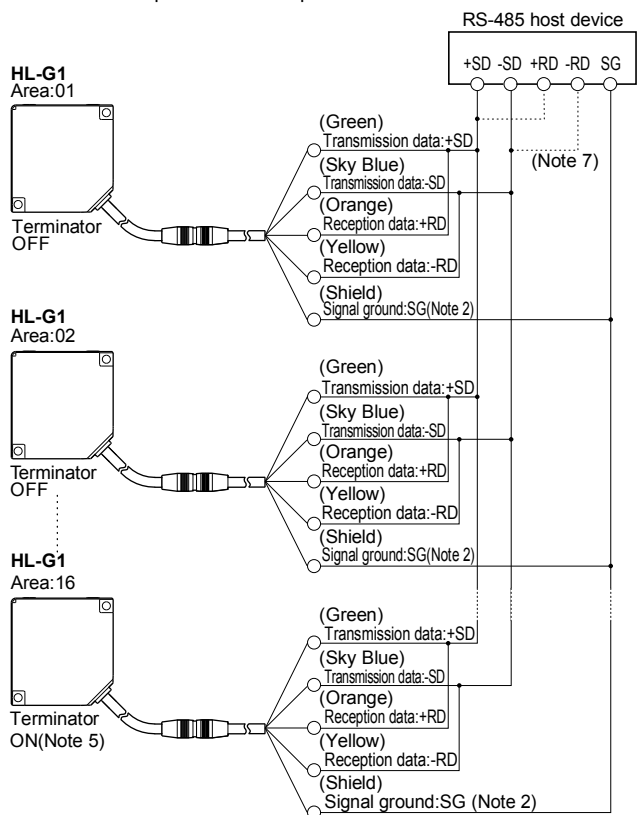

- Notes:
- 1) The transmission data cable and reception data cable are both twisted-pair cables.
  - 2) The shield is connected to the 0 V side of the power supply line inside the sensor.
  - 3) Be sure to connect the signal ground.
  - 4) The sensor is of non-isolated type. Make sure that the potential difference between the sensor and RS-485 connecting device does not exceed 4 V. A difference in potential in excess may cause the connecting device or the sensor to malfunction.
  - 5) The sensor has a built-in terminating resistor. Be sure to turn ON the terminating resistor of the terminating sensor.
  - 6) Perform transition wiring for the transmission path.
  - 7) Connect the wires according to the specification of the equipment.

**SENSING CHARACTERISTICS (TYPICAL)**

**Correlation between measuring distance and error characteristics**

**Diffuse reflection type**

White ceramic  
Vertical orientation

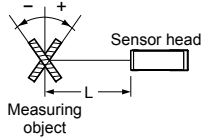

White ceramic  
Horizontal orientation

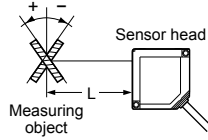

**Specular reflection type**

Aluminum vapor deposition  
surface reflection mirror  
Vertical orientation

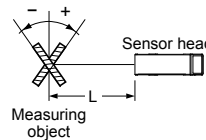

Aluminum vapor deposition  
surface reflection mirror  
Horizontal orientation

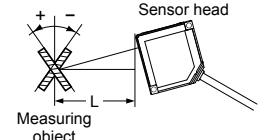

**HL-G103** Diffuse reflection type

Vertical positioning

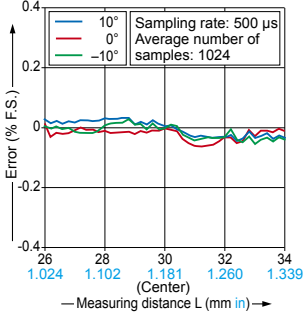

Horizontal positioning

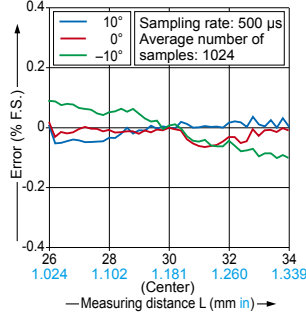

**HL-G105** Diffuse reflection type

Vertical positioning

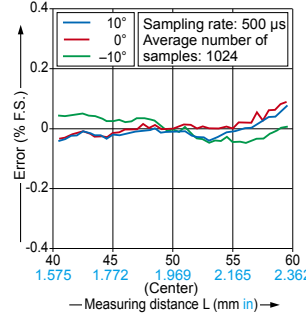

Horizontal positioning

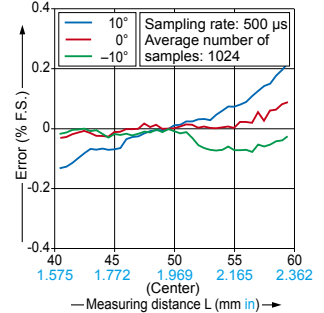

**HL-G108** Diffuse reflection type

Vertical positioning

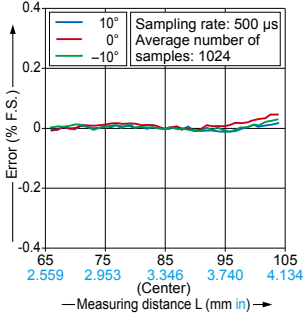

Horizontal positioning

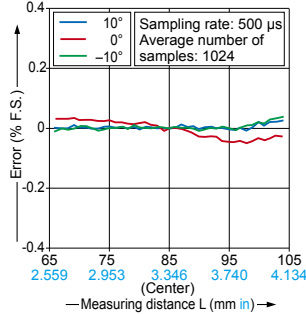

**HL-G112** Diffuse reflection type

Vertical positioning

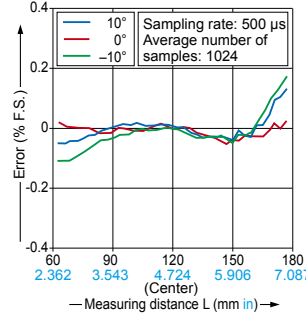

Horizontal positioning

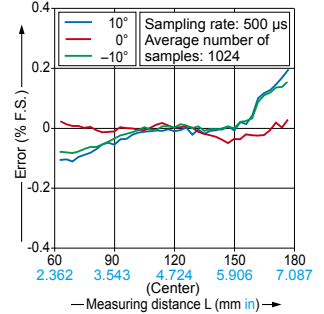

**HL-G125** Diffuse reflection type

Vertical positioning

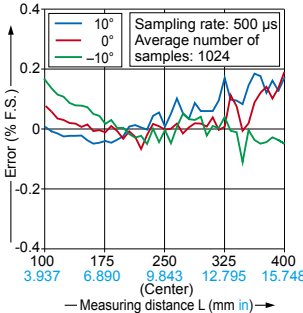

Horizontal positioning

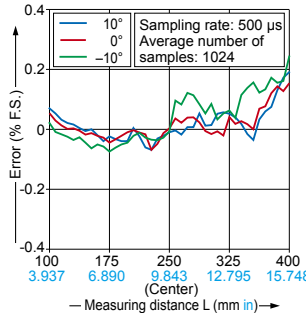

**HL-G103A** Specular reflection type

Vertical positioning

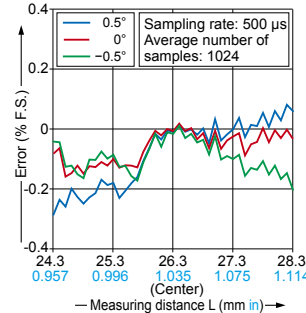

Horizontal positioning

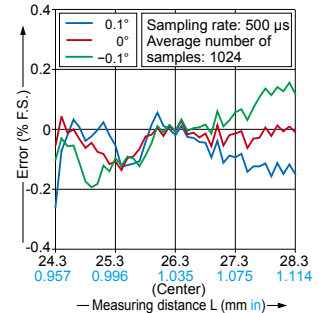

**HL-G105A** Specular reflection type

Vertical positioning

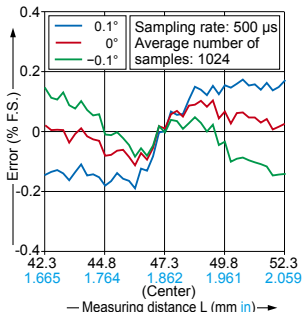

Horizontal positioning

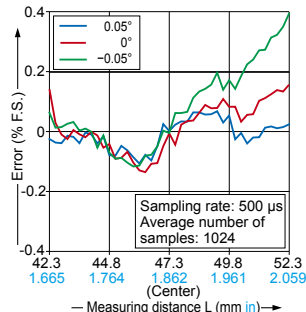

**HL-G108A** Specular reflection type

Vertical positioning

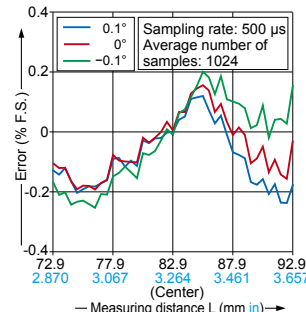

Horizontal positioning

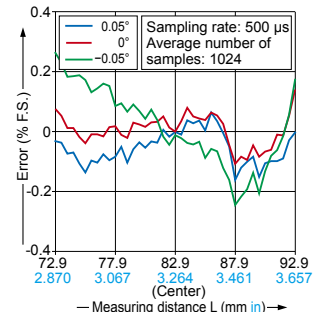

FIBER SENSORS

LASER SENSORS

PHOTO-ELECTRIC SENSORS

MICRO PHOTO-ELECTRIC SENSORS

AREA SENSORS

SAFETY LIGHT CURTAINS / SAFETY COMPONENTS

PRESSURE / FLOW SENSORS

INDUCTIVE PROXIMITY SENSORS

PARTICULAR USE SENSORS

SENSOR OPTIONS

SMALL WIRE-SAVING UNITS

WIRE-SAVING SYSTEMS

MEASURE-MENT SENSORS

STATIC CONTROL DEVICES

LASER MARKERS

PLC

HUMAN MACHINE INTERFACES

ENERGY MANAGEMENT SOLUTIONS

FA COMPONENTS

MACHINE VISION SYSTEMS

UV CURING SYSTEMS

Selection Guide

Laser Displacement

Magnetic Displacement

Contact Displacement

Collimated Beam Sensors

Metal-sheet Double-feed Detection

Digital Panel Controller

Other Products

HL-G1

HL-C2

HL-D3

**PRECAUTIONS FOR PROPER USE**

Refer to p.1595 for general precautions and p.1593~ for information about laser beam.



- Never use this product as a sensing device for personnel protection.
- In case of using sensing devices for personnel protection, use products which meet laws and standards, such as OSHA, ANSI or IEC etc., for personnel protection applicable in each region or country.



- Do not operate products using methods other than the ones described in the instruction manual included with each product. Control or adjustment through procedures other than the ones specified may cause hazardous laser radiation exposure.
- The following labels are attached to the product. Handle the product according to the instruction given on the warning label.  
(The Japanese, English, Chinese, Korean warning labels are included in the package of the diffuse reflection type (HL-G1□-S-J / HL-G1□-A-C5).)

**HL-G1□-S-J / HL-G1□-A-C5**

- This product is classified as a Class 2 Laser Product in IEC / JIS standards and FDA\* regulations. Do not look at the laser beam directly or through optical system such as a lens.



**HL-G1□A-RS-J / HL-G1□A-RA-C5**

- This product is classified as a Class 1 Laser Product in IEC / JIS standards and FDA\* regulations. Do not look at the laser beam through optical devices such as a lens.



\*This product complies with 21 CFR 1040.10 and 1040.11 Laser Notice No. 50, dated June 24, 2007, issued by CDRH (Center for Devices and Radiological Health) under the FDA (Food and Drug Administration).

**Beam diameter (Unit: mm in)**

**Diffuse reflection type**

**Specular reflection type**

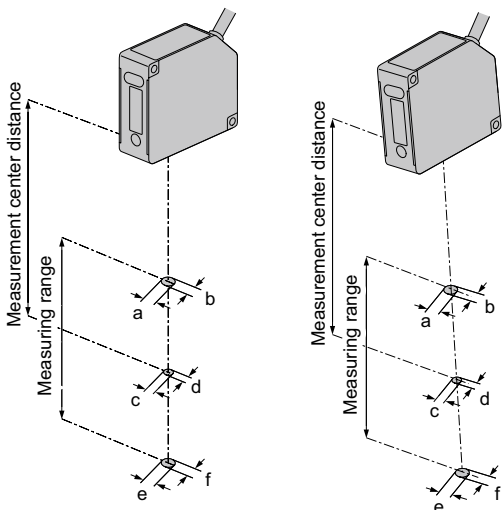

Type	Model No.	Beam diameter (Unit: mm in)					
		a	b	c	d	e	f
Diffuse reflection type	HL-G103-S-J HL-G103-A-C5	0.15 0.006	0.15 0.006	0.1 0.004	0.1 0.004	0.15 0.006	0.15 0.006
	HL-G105-S-J HL-G105-A-C5	1.2 0.047	0.6 0.024	1.0 0.039	0.5 0.020	0.9 0.035	0.4 0.016
	HL-G108-S-J HL-G108-A-C5	1.5 0.059	0.9 0.030	1.25 0.049	0.75 0.030	1.0 0.039	0.6 0.024
	HL-G112-S-J HL-G112-A-C5	1.8 0.071	1.2 0.047	1.5 0.059	1.0 0.039	0.8 0.031	0.5 0.020
	HL-G125-S-J HL-G125-A-C5	2.5 0.098	1.5 0.059	3.5 0.138	1.75 0.069	4.5 0.177	2.0 0.079
Specular reflection type	HL-G103-RS-J HL-G103-RA-C5	0.15 0.006	0.15 0.006	0.1 0.004	0.1 0.004	0.15 0.006	0.15 0.006
	HL-G105-RS-J HL-G105-RA-C5	0.15 0.006	0.15 0.006	0.1 0.004	0.1 0.004	0.15 0.006	0.15 0.006
	HL-G108-RS-J HL-G108-RA-C5	0.2 0.008	0.2 0.008	0.2 0.008	0.2 0.008	0.2 0.008	0.2 0.008

**Sensor mounting direction**

- To obtain the greatest precision, the sensor head should be oriented facing the direction of movement of the object's surface, as shown in the figure below.

**Object with variations in material or color**

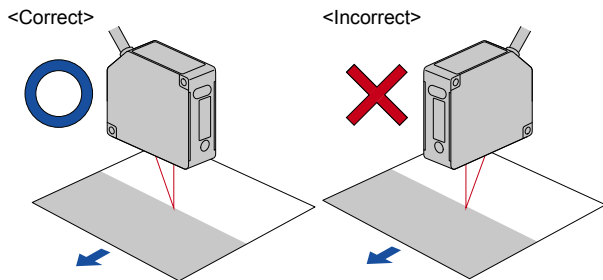

**Rotating object**

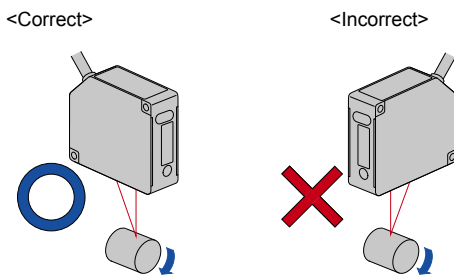

**Object that has large differences in gaps, grooves and colors**

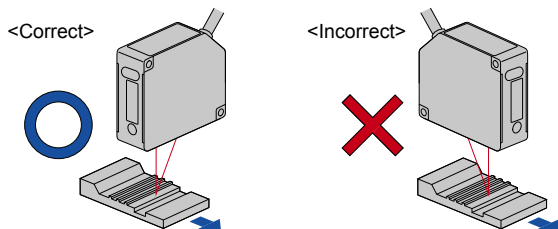

**PRECAUTIONS FOR PROPER USE**

Refer to p.1595 for general precautions and p.1593~ for information about laser beam.

**Mutual interference** (Unit: mm in)

- When installing two or more sensor heads side by side, mutual interference will not occur if the laser spots from other sensor heads do not fall within the shaded areas in the figure below.

**HL-G103**

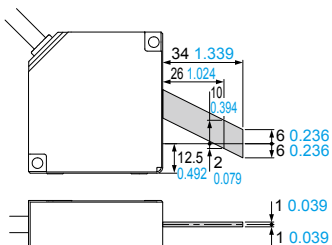

**HL-G105**

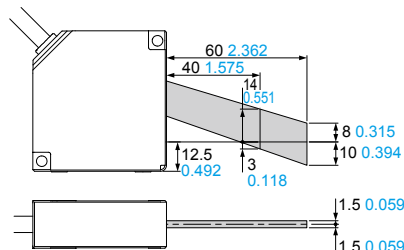

**HL-G108**

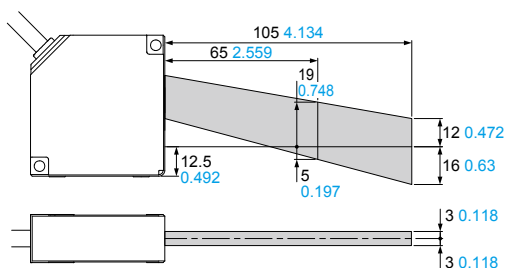

**HL-G112**

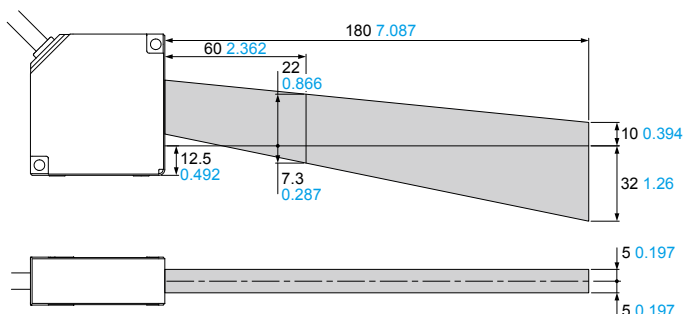

**HL-G125**

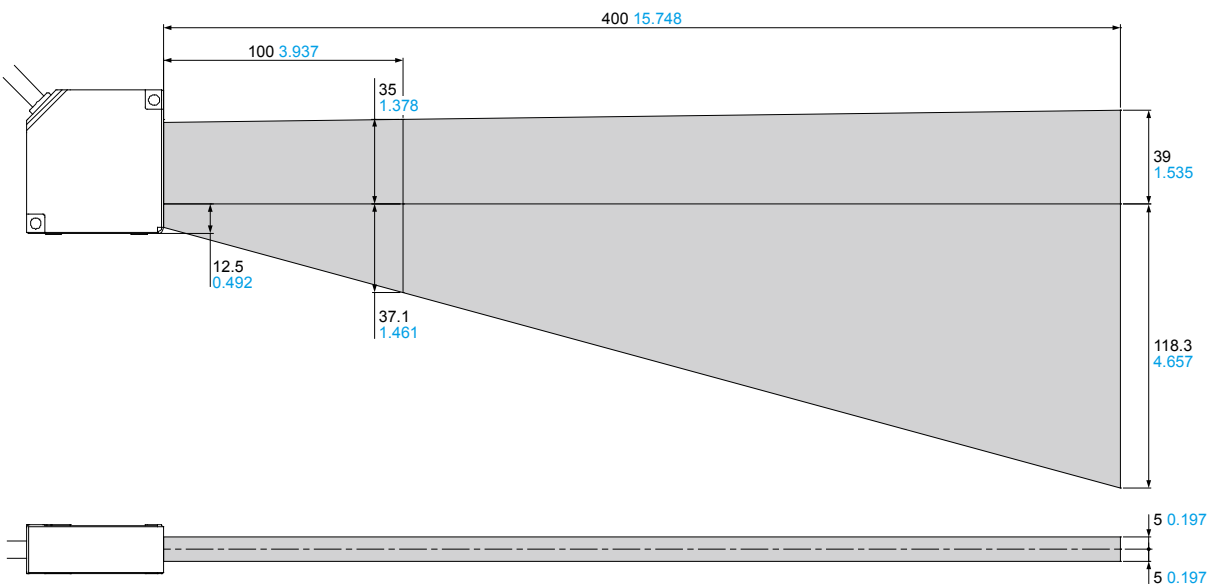

FIBER SENSORS

LASER SENSORS

PHOTO-ELECTRIC SENSORS

MICRO PHOTO-ELECTRIC SENSORS

AREA SENSORS

SAFETY LIGHT CURTAINS / SAFETY COMPONENTS

PRESSURE / FLOW SENSORS

INDUCTIVE PROXIMITY SENSORS

PARTICULAR USE SENSORS

SENSOR OPTIONS

SIMPLE WIRE-SAVING UNITS

WIRE-SAVING SYSTEMS

MEASUREMENT SENSORS

STATIC CONTROL DEVICES

LASER MARKERS

PLC

HUMAN MACHINE INTERFACES

ENERGY MANAGEMENT SOLUTIONS

FA COMPONENTS

MACHINE VISION SYSTEMS

UV CURING SYSTEMS

Selection Guide

Laser Displacement

Magnetic Displacement

Contact Displacement

Collimated Beam Sensors

Metal-sheet Double-feed Detection

Digital Panel Controller

Other Products

**HL-G1**

**HL-C2**

**HL-D3**

**DIMENSIONS (Unit: mm in)**

The CAD data can be downloaded from our website.

FIBER SENSORS

LASER SENSORS

PHOTO-ELECTRIC SENSORS  
MICRO PHOTO-ELECTRIC SENSORS

AREA SENSORS

SAFETY LIGHT CURTAINS / SAFETY COMPONENTS

PRESSURE / FLOW SENSORS

INDUCTIVE PROXIMITY SENSORS

PARTICULAR USE SENSORS

SENSOR OPTIONS

SIMPLE WIRE-SAVING UNITS

WIRE-SAVING SYSTEMS

MEASURE-MENT SENSORS

STATIC CONTROL DEVICES

LASER MARKERS

PLC

HUMAN MACHINE INTERFACES

ENERGY MANAGEMENT SOLUTIONS

FA COMPONENTS

MACHINE VISION SYSTEMS

UV CURING SYSTEMS

Selection Guide

Laser Displacement

Magnetic Displacement

Contact Displacement

Collimated Beam Sensors

Metal-sheet Double-feed Detection

Digital Panel Controller

Other Products

**HL-G1**

**HL-C2**

**HL-D3**

**HL-G1□-A-C5**

Sensor (Diffuse reflection / Standard type)

Model No.	Measurement center distance (ℓ)	θ
<b>HL-G103-A-C5</b>	30 <b>1.181</b>	30°
<b>HL-G105-A-C5</b>	50 <b>1.969</b>	21°
<b>HL-G108-A-C5</b>	85 <b>3.346</b>	15°
<b>HL-G112-A-C5</b>	120 <b>4.724</b>	11°
<b>HL-G125-A-C5</b>	250 <b>9.843</b>	6.2°

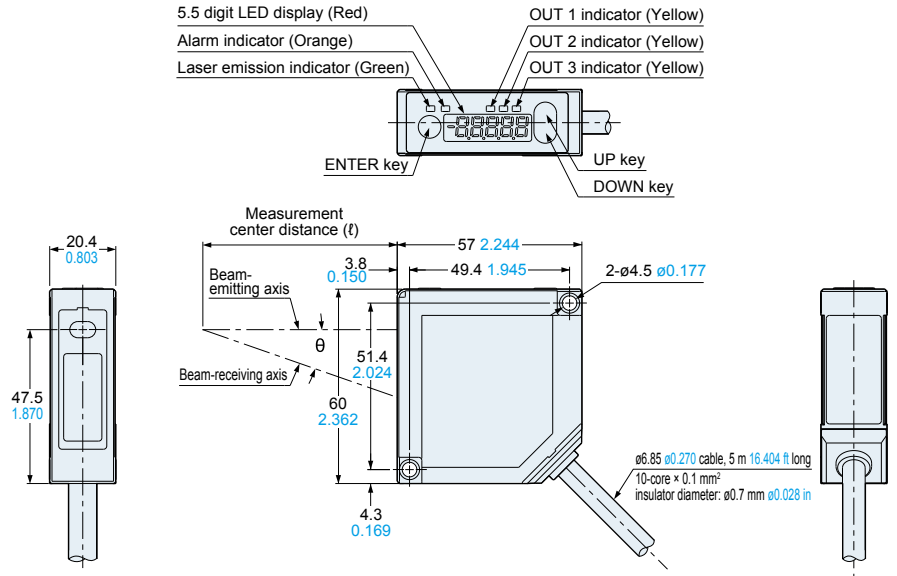

**HL-G1□-S-J**

Sensor (Diffuse reflection / High function type)

Model No.	Measurement center distance (ℓ)	θ
<b>HL-G103-S-J</b>	30 <b>1.181</b>	30°
<b>HL-G105-S-J</b>	50 <b>1.969</b>	21°
<b>HL-G108-S-J</b>	85 <b>3.346</b>	15°
<b>HL-G112-S-J</b>	120 <b>4.724</b>	11°
<b>HL-G125-S-J</b>	250 <b>9.843</b>	6.2°

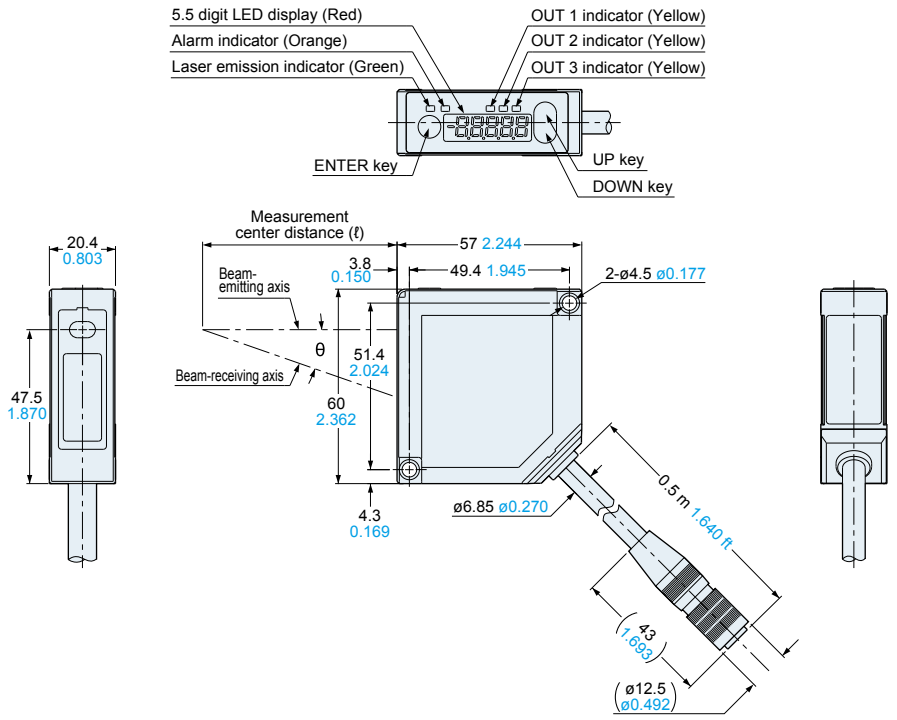

**HL-G1CCJ□**

Extension cable (Optional)

Model No.	L
<b>HL-G1CCJ2</b>	2,000 <sup>+200</sup> / <sub>0</sub> <b>78.740</b> <sup>+7.874</sup> / <sub>0</sub>
<b>HL-G1CCJ5</b>	5,000 <sup>+500</sup> / <sub>0</sub> <b>196.850</b> <sup>+19.685</sup> / <sub>0</sub>
<b>HL-G1CCJ10</b>	10,000 <sup>+1,000</sup> / <sub>0</sub> <b>393.701</b> <sup>+39.370</sup> / <sub>0</sub>
<b>HL-G1CCJ20</b>	20,000 <sup>+2,000</sup> / <sub>0</sub> <b>787.402</b> <sup>+78.740</sup> / <sub>0</sub>

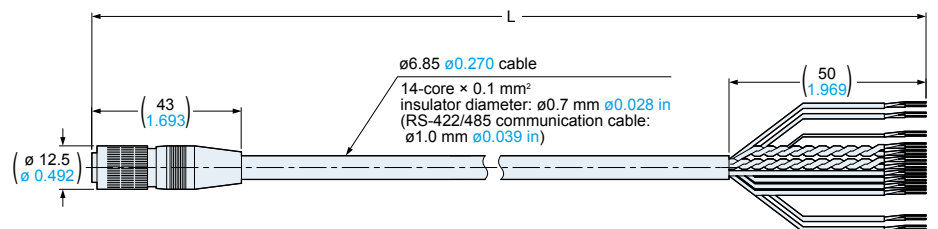

**DIMENSIONS (Unit: mm in)**

The CAD data can be downloaded from our website.

**HL-G103A-RA-C5** Sensor (Specular reflection / Standard type)

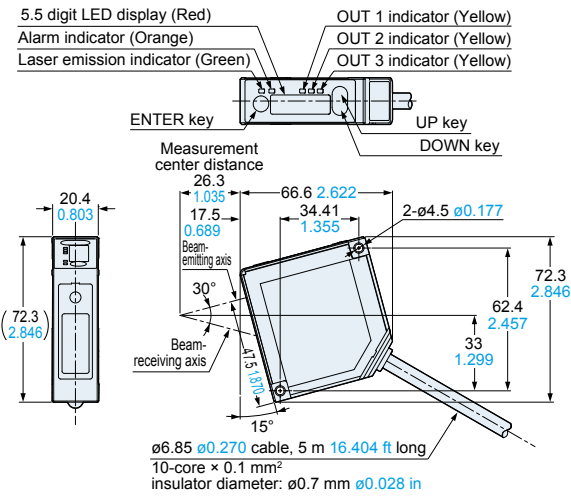

**HL-G103A-RS-J** Sensor (Specular reflection / High function type)

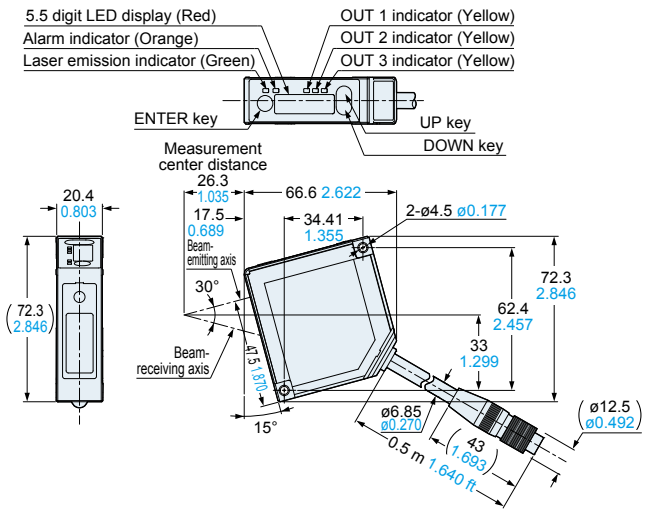

**HL-G105A-RA-C5** Sensor (Specular reflection / Standard type)

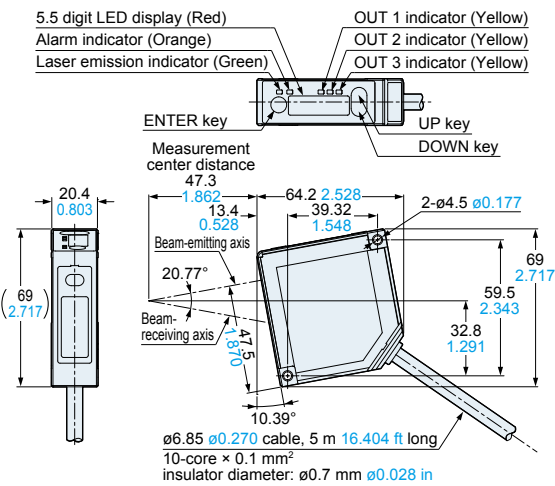

**HL-G105A-RS-J** Sensor (Specular reflection / High function type)

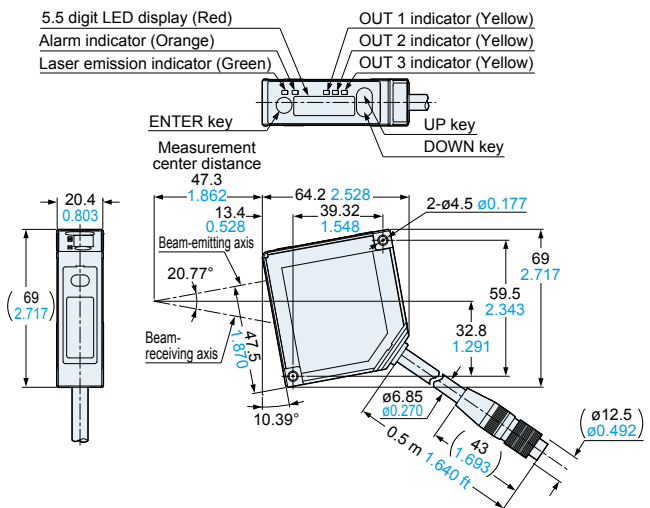

**HL-G108A-RA-C5** Sensor (Specular reflection / Standard type)

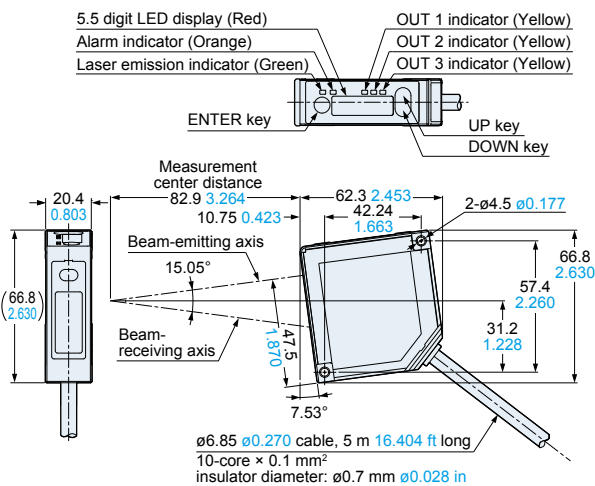

**HL-G108A-RS-J** Sensor (Specular reflection / High function type)

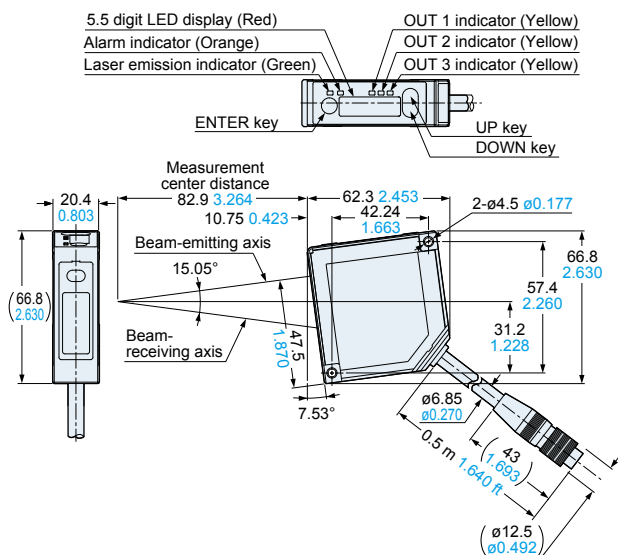

FIBER SENSORS

LASER SENSORS

PHOTO-ELECTRIC SENSORS

MICRO PHOTO-ELECTRIC SENSORS

AREA SENSORS

SAFETY LIGHT CURTAINS / SAFETY COMPONENTS

PRESSURE / FLOW SENSORS

INDUCTIVE PROXIMITY SENSORS

PARTICULAR USE SENSORS

SENSOR OPTIONS

SIMPLE WIRE-SAVING UNITS

WIRE-SAVING SYSTEMS

MEASURE-MENT SENSORS

STATIC CONTROL DEVICES

LASER MARKERS

PLC

HUMAN MACHINE INTERFACES

ENERGY MANAGEMENT SOLUTIONS

FA COMPONENTS

MACHINE VISION SYSTEMS

UV CURING SYSTEMS

Selection Guide

Laser Displacement

Magnetic Displacement

Contact Displacement

Collimated Beam Sensors

Metal-sheet Double-feed Detection

Digital Panel Controller

Other Products

**HL-G1**

**HL-C2**

**HL-D3**