

REV.	ECN. NO.	APPD.
A	BC-09-7066840	Hao Gu
B	BC-09-7079730	Hao Gu
C	BC-10-0037432	Adward
D	BC-11-0023299	Adward

**SPECIFICATION**

- 1-ELECTRICAL CHARACTERISTICS:
- 1-1-1.CONTACT CURRENT RATING : 5 AMPERES
  - 1-1-2.CONTACT VOLTAGE RATING : 16 VDC.
  - 1-1-3.CONTACT RESISTANCE: 30MILLIOHMS MAX.  
AT AC 100mA(MAX.)1KHz
  - 1-1-4.DIELECTRIC WITHSTANDING VOLTAGE:500VAC MIN.  
60 Hz FOR 1 MINUTE
  - 1-1-5.INSULATION RESISTANCE:100MEGOHMS MIN.  
AT 500 VDC
- 1-2.MECHANICAL CHARACTERISTICS
- 1-2-1.CONECTOR MATING & UNMATING FORCE  
INITIAL :2.94N TO 29.4N  
AFTER LIFE TEST :1.96N TO 29.4N
  - 1-2-2.LIFE TEST 5,000 CYCLES UNLOADING.
- 1-3.ENVIRONMENT CHARACTERISTICS:
- 1-3-1.OPERATING TEMPERATURE : -40°C TO +70°C
- 1-4.RECOMMENDED PROCESS:  
WAVE SOLDER 260°C(MAX.),FOR 3~5s.  
OR IR REFLOW PEAK TEMPERATURE:230~250°C,20~40s

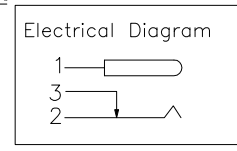
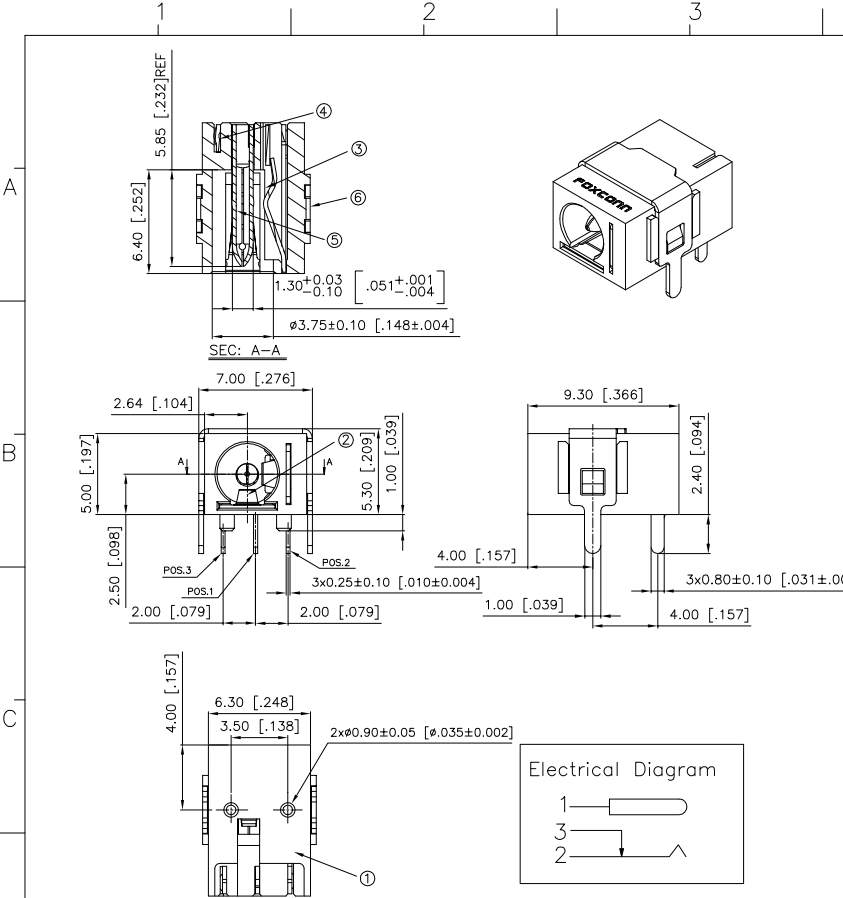
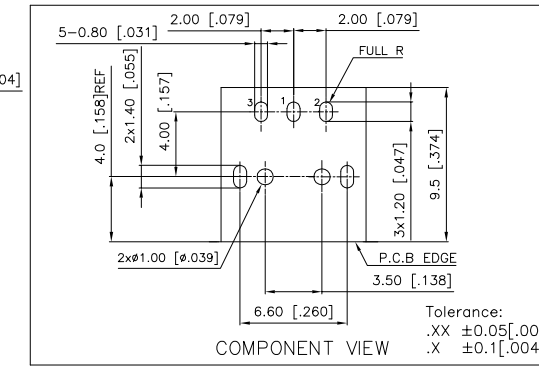
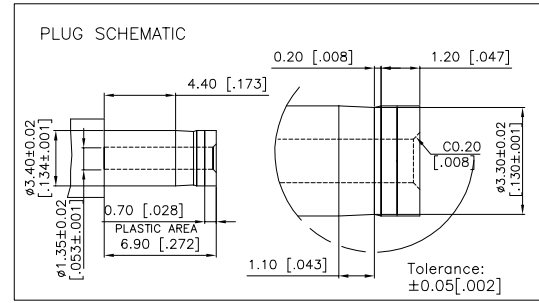

NOTES:  
1.RECOMMENDED PCB IS 1.0~1.2 MM THICK.  
2.PRODUCT MEET LEAD FREE IN MANUFACTURE FLOW

PROD. NO.: JP D 1 0 3 0 - M301 - 7 F LEAD FREE

JP:POWER JACK PACKAGE CODE  
D:D/C 7=TAPE REEL  
POWER TYPE MODIFY CODE  
TERMINATOR TYPE CONTACT PLATING  
1:R/A THROUGH HOLE 0: 100~200u" TIN  
CONTACT TYPE NO. OF CONTACT  
0:MALE 3:3PIN

6	SHELL	1	COPPER ALLOY	NICKEL UNDER PLATING OVER ALL Pd PLATED OVER NICKEL.	
5	CENTER PIN	1	COPPER ALLOY	NICKEL UNDER PLATING OVER ALL TIN ALLOY (LEAD FREE) OVER NICKEL.	
4	SWITCH CONTACT	1	COPPER ALLOY	NICKEL UNDER PLATING OVER ALL TIN ALLOY (LEAD FREE) OVER NICKEL.	
3	SPRING CONTACT	1	COPPER ALLOY	NICKEL UNDER PLATING OVER ALL TIN ALLOY (LEAD FREE) OVER NICKEL.	
2	SPRING PLATE	1	STAINLESS STEEL	CLEANING	
1	HOUSING	1	THERMOLPLASTIC HI-TEMP UL94V-0	MOLDED COLOR:BLACK	
ITEM	DESCRIPTION	Q'TY	MATERIAL	TREATMENT	REMARK

X. ±	X° ±	UNITS mm [INCH]	NAME(INTENDED USE)	<b>FOXCONN</b> HON HAI PRECISION IND. CO.,LTD. TAIPEI, TAIWAN, R.O.C.
.X ±	.X° ±	MAT'L	CUSTOMER	
.XX ± <sup>0.20</sup> <sub>[.008]</sub>	.XX° ±	N/A	PART NO.(INTENDED USE)	TITLE:
.XXX ±	.XXX° ±	FINISH	JPD1030-M301-7F	MINI 3 PIN POWER JACK
THESE DRAWINGS AND SPECIFICATIONS ARE THE PROPERTY OF HON HAI PRECISION IND. CO., LTD. AND SHALL NOT BE REPRODUCED, COPIED OR USED IN ANY MANNER WITHOUT THE PRIOR WRITTEN CONSENT OF HON HAI PRECISION IND. CO., LTD.			APPD: Jesse Wang 3/4'11	DWG NO.: 305-0000-3777
			CHKD: F.H Shu 3/4'11	SCALE SHEET REV.
			DR: Tong Zhu 3/4'11	N/A 1/1 D