



Frontier Electronics Corp.

667 E. COCHRAN STREET, SIMI VALLEY, CA 93065

TEL: (805) 522-9998 FAX: (805) 522-9989

E-mail: frontiersales@frontierusa.com

Web: <http://www.frontierusa.com>

1.5A FAST RECOVERY PLASTIC RECTIFIER

FR15-005-LFR THRU FR15-10-LFR

FEATURES

- LOW COST
- DIFFUSED JUNCTION
- LOW LEAKAGE
- LOW FORWARD VOLTAGE DROP
- HIGH CURRENT CAPABILITY
- FAST SWITCHING
- ROHS

MECHANICAL DATA

- CASE: JEDEC DO-15 MOLDED PLASTIC, DO15, DIMENSIONS IN INCHES AND (MILLIMETERS)
- TERMINAL: AXIAL LEADS, SOLDERABLE PER MIL-STD-202, METHOD 208
- POLARITY: COLOR BAND DENOTES CATHODE
- MOUNTING POSITION: ANY
- WEIGHT: 0.4 GRAMS

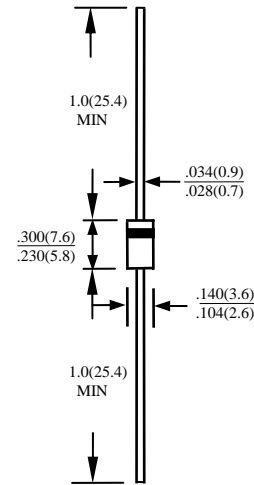

MAXIMUM RATINGS AND ELECTRICAL CHARACTERISTICS RATINGS AT 25°C AMBIENT TEMPERATURE UNLESS OTHERWISE SPECIFIED SINGLE PHASE, HALF WAVE, 60 HZ, RESISTIVE OR INDUCTIVE LOAD. FOR CAPACITIVE LOAD, DERATE CURRENT BY 20%

RATINGS	SYMBOL	FR15-005-LFR	FR15-01-LFR	FR15-02-LFR	FR15-04-LFR	FR15-06-LFR	FR15-08-LFR	FR15-10-LFR	UNITS
MAXIMUM RECURRENT PEAK REVERSE VOLTAGE	V _{RRM}	50	100	200	400	600	800	1000	V
MAXIMUM RMS VOLTAGE	V _{RMS}	35	70	140	280	420	560	700	V
MAXIMUM DC BLOCKING VOLTAGE	V _{DC}	50	100	200	400	600	800	1000	V
MAXIMUM AVERAGE FORWARD RECTIFIED CURRENT 0.375" (9.5mm) LEAD LENGTH AT TA=55°C	I _O	1.5							A
PEAK FORWARD SURGE CURRENT, 8.3ms SINGLE HALF SINE-WAVE SUPERIMPOSED ON RATED LOAD	I _{FSM}	50							A
TYPICAL JUNCTION CAPACITANCE (NOTE 1)	C _J	25							PF
TYPICAL THERMAL RESISTANCE (NOTE 2)	R _{θja}	40							°C/W
STORAGE TEMPERATURE RANGE	T _{STG}	-55 TO + 150							°C
OPERATING TEMPERATURE RANGE	T _{OP}	-55 TO + 150							°C

ELECTRICAL CHARACTERISTICS (A_T T_A =25°C UNLESS OTHERWISE NOTED)

CHARACTERISTICS	SYMBOL	FR15-005-LFR	FR15-01-LFR	FR15-02-LFR	FR15-04-LFR	FR15-06-LFR	FR15-08-LFR	FR15-10-LFR	UNITS
MAXIMUM FORWARD VOLTAGE AT I _O DC	V _F	1.3							V
MAXIMUM REVERSE CURRENT AT 25°C	I _R	5							μA
MAXIMUM REVERSE CURRENT AT 100°C	I _R	50							μA
MAXIMUM REVERSE RECOVERY TIME (NOTE3)	T _{RR}	150			250		500		nS

- NOTE: 1. MEASURED AT 1 MHZ AND APPLIED REVERSE VOLTAGE OF 4.0 VOLTS
 2. BOTH LEADS ATTACHED TO HEAT SINK 20x20x1t(mm) COPPER PLATE AT LEAD LENGTH 5mm
 3. REVERSE RECOVERY TEST CONDITIONS: I_F=0.5A, I_R=1.0A, I_{RR}=0.25A

RATINGS AND CHARACTERISTIC CURVE FR15-005-LFR THRU FR15-10-LFR

FIG. 1-TEST CIRCUIT DIAGRAM AND REVERSE RECOVERY TIME CHARACTERISTIC

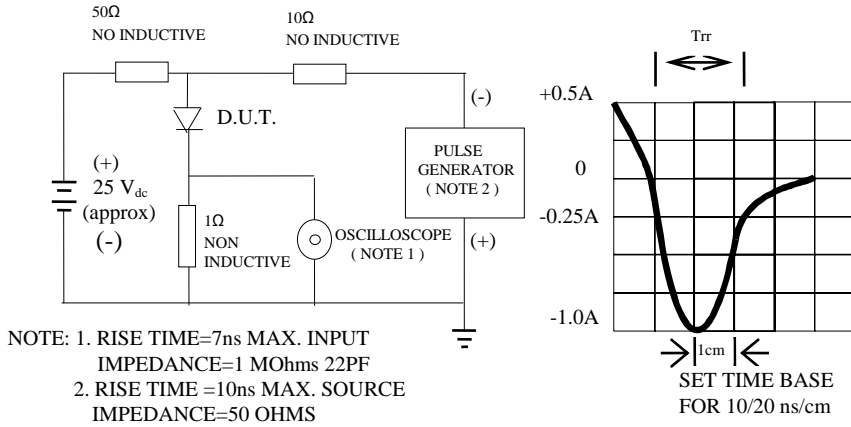

Fig. 2-MAXIMUM CURRENT DERATING CURVE

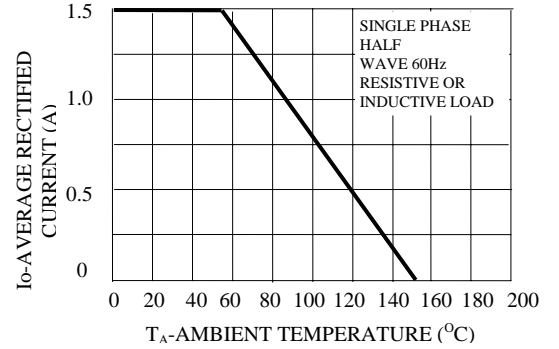

FIG. 3-TYPICAL REVERSE CHARACTERISTICS

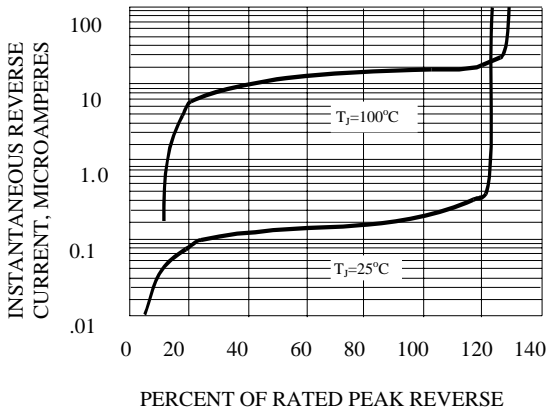

Fig. 4-MAXIMUM FORWARD SURGE NUMBER OF CYCLES

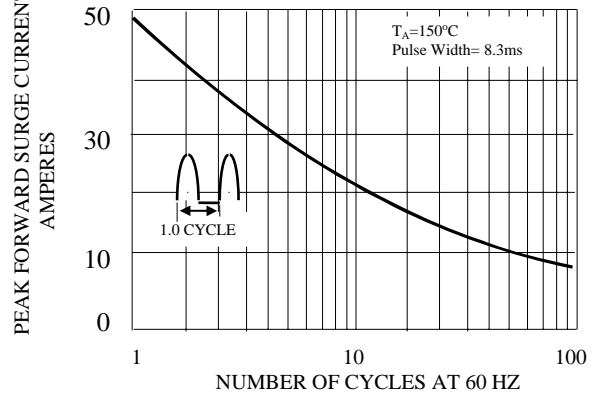

FIG. 5-TYPICAL JUNCTION CAPACITANCE

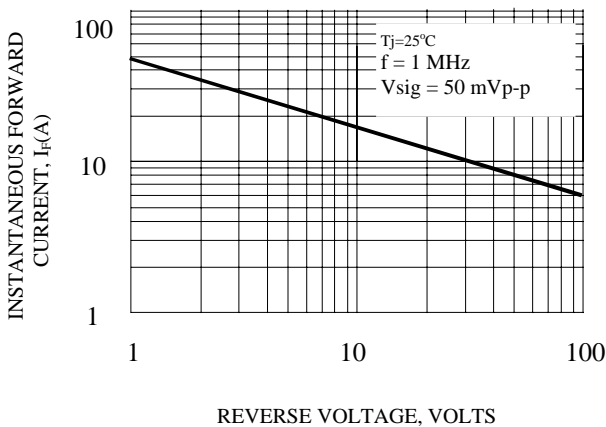

FIG. 6-TYPICAL INSTANTANEOUS FORWARD CHARACTERISTICS

