

## Highly Integrated USB PD Type-C Controller for SMPS

### General Description

The RT7202K is a simple and yet flexible for multipurpose of USB PD controller. By programming, it could operate as a source or a sink.

When used as a source, it could be used in an off-line AC-DC converter, as it integrates shunt regulator, constant voltage (CV) and constant current (CC) control loop with programmable reference voltage to meet the specification of Programmable Power Supply (PPS) specification. When combined with external buck or buck boost controller, it could constitute a DCDC converter, such as a car charger, and could also meet the PPS specification. When used as a sink, it is simple, low cost, yet flexible to use to request required power from a source. If using the RT7202KD for a sink design, it has I<sup>2</sup>C interface and two GPIOs for flexible use and could be easily controlled by other MCU which plays a master role.

### Ordering Information

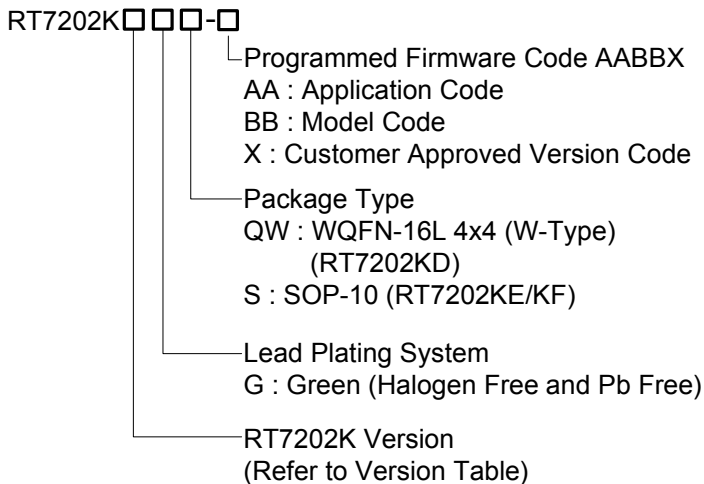

Note :

Richtek products are :

- RoHS compliant and compatible with the current requirements of IPC/JEDEC J-STD-020.
- Suitable for use in SnPb or Pb-free soldering processes.

### Features

- **Protocols Supported**
  - USB PD 2.0 and 3.0 (PPS)
  - Other Proprietary Protocols
- **Highly Integrated**
  - Embedded MCU with an Mask-ROM of 24kB, an OTP-ROM of 8kB, and an SRAM of 2kB
  - Embedded BMC Transceiver
  - Wide V<sub>DD</sub> Operation Range : 3V to 22V
  - Built-in Shut Regulator for Constant-Voltage and Constant-Current Regulation
  - Built-in 10-bit Analog-to-Digital Converter (ADC)
  - Programmable Cable Compensation
  - BLD Pin for Quick Discharge of Output Capacitor (RT7202KD)
  - VDD Pin for Quick Discharge of Output Capacitor (RT7202KE/KF)
  - USBP Pin for Direct Drive of External Blocking N-MOSFET
  - Power-Saving Mode in Standby Mode
- **Protection**
  - Adaptive Over-Voltage Protection
  - Adaptive Under-Voltage Protection
  - Firmware-Programmable Over-Current Protection

### Applications

- USB PD Type-C Chargers/Adapters for Smart Phones, NBs, Tablets and All Other Electronics
- USB PD Extension Cores with Offline AC-DC Converters

### Marking Information

For marking information, contact our sales representative directly or through a Richtek distributor located in your area.