

KEY FEATURES

- Power Module for PCB Mountable
- Smaller Size
- 4:1 Wide Input Range
- Regulated Output
- High Efficiency
- Operating Temperature: -40°C...+80°C (with derating)
- Remote ON/OFF Control
- Protections: Over Voltage / Over Temperature / Short Circuit All by Auto-recovery
- 3-Year Product Warranty



ELECTRICAL SPECIFICATIONS

All specifications valid at normal input voltage, full load and +25°C after warm-up time unless otherwise stated.

Model No. with Heatsink (Single Output)	ST60-48F-12S X	ST60-48F-15S X	ST60-48F-24S X	
Model No. without Heatsink (Single Output)	ST60-48F-12S	ST60-48F-15S	ST60-48F-24S	
Max Output Wattage (W) with Heatsink (at 48 Vin)	60W			
Max Output Wattage (W) without Heatsink (at 48 Vin)	60W	55.5W	56.4W	
Input Voltage (with Derating)	48V (18-72V)			
Remote ON/OFF	DC-DC ON	Open		
	DC-DC OFF	When -DC IN and ON/OFF CTL is Short		
Output	Voltage (V.DC.)	12	15	24
	Trim Voltage Range	±5%	±5%	None
	Voltage Accuracy	±2%		
	Current (mA) with Heatsink (max.)	5000	4000	2500
	Current (mA) without Heatsink (max.)	5000	3700	2350
	Line Regulation (LL-HL) (typ.)	±0.5%		
	Load Regulation (10-100%) (typ.)	±1%		
	Capacitor Load (max) (at 48 Vin)	800uF	500uF	220uF
	Ripple & Noise (Note 1)	150mV	1% of Vout	1% of Vout
	Efficiency (at 48 Vin)	91%	90%	90%
Protection	Over Power Protection	Auto-recovery		
	Over Voltage Protection	Zener diode clamp		
	Over Temperature	Auto-recovery		
	Short Circuit Protection	Auto-recovery		
Isolation	Voltage	1600 VDC.		
	Resistance	10 ⁸ ohms		
	Capacitance (typ.)	2420 pF		
Environment	Operating Temperature (Note 2)	-40°C...+80°C (with derating)		
	Storage Temperature	-45°C...+100°C		
	Case Temperature	+100°C max.		
	Temperature Coefficient	±0.05%/°C		
	Humidity	95% RH		
	MTBF	>550,000 h @ 25°C (MIL-HDBK-217F)		
Physical	Dimension (L x W x H)	2.08 x 1.08 x 0.53 Inches (52.8 x 27.5 x 13.5 mm) Tolerance ±0.5 mm		
	Case Material	Six-side shielded Aluminum with Non-Conductive base, Black Anodize		
	Weight	Pending		
	Cooling Method	Free-air convection		
Safety	Agency Approvals	CE, UL, cUL (Pending)		
EMC	EMI (Conducted & Radiated Emission) (Note 3)	EN 55022 class A (Pending)		
	EMS (Noise Immunity)	EN 55024 (Pending)		

NOTE

1. Ripple & Noise are measured at 20MHz of bandwidth with ceramic 0.1uF & chemi-con KY 47uF parallel capacitor.

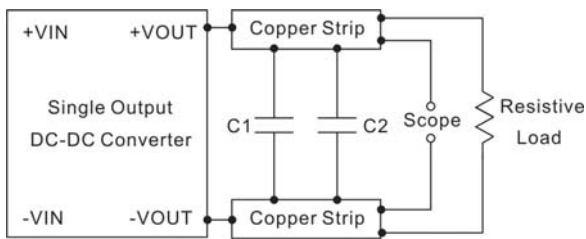

C1=0.1u~1uF
C2=47u~100uF

Use a Cout ceramic capacitor. Please refer to capacitor value of every series. Scope measurement should be made by using a BNC socket, measurement bandwidth is 0-20 MHz. Position the load between 50 mm and 75 mm from the DC-DC Converter.

2. That "natural convection" is about 20LFM but is not equal to still air (0 LFM).
3.

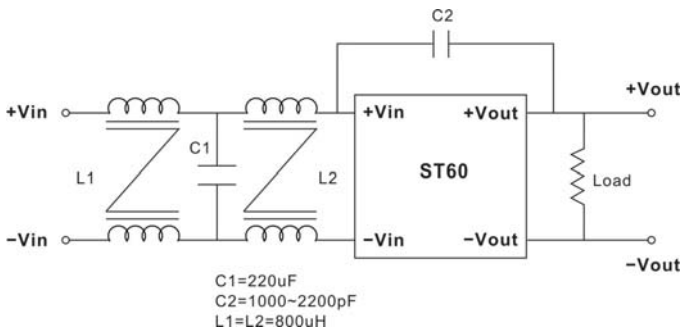

C1=220uF
C2=1000~2200pF
L1=L2=800uH

4. Please refer to our PDF file "DC-DC Application" on our website: www.archcorp.com.tw

MECHANICAL DIMENSION (Top View)

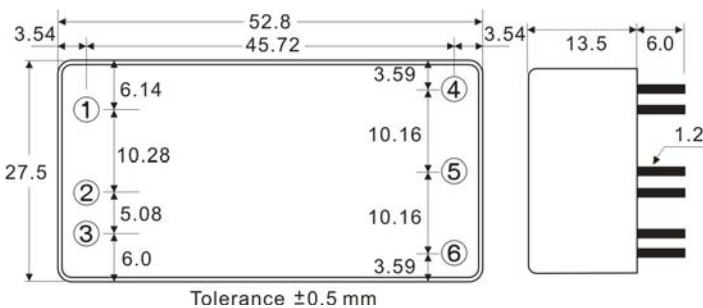

PIN#	Single
1	CTRL
2	-DC IN
3	+DC IN
4	TRIM
5	-DC OUT
6	+DC OUT

TRIM

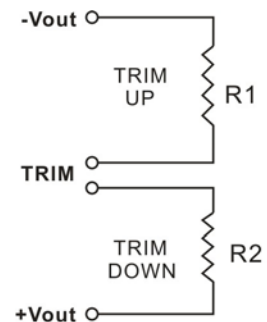

	R1	R2
12S	0~560KΩ	75K~680KΩ
15S	0~330KΩ	150K~1MΩ

DERATING

