

TQM7M9053

(Quad band GSM-EDGE and Tri-Band W/CDMA/HSPA+/LTE)

Applications

- GSM/EDGE/WEDGE Applications
- WCDMA B1/8 or B1/5 Applications
- WCDMA B1/5/8 Applications (w/ external switch)
- HSDPA/HSUPA/HSPA+ Applications
- LTE Applications / EVDO revA/B B1&B5

Product Features

- Quad-Band Linear GSM/EDGE
- UMTS B1 and B5/8
- Input power controlled – GMSK and 8PSK
- GSM LB has 2 modes – HP, LP
- GSM HB has 2 modes – HP, LP
- W/CDMA has 2 modes – HP, MP
- HBT/PHEMT / CuFlip® PA Technology
- Integrated coupler
- Built-in voltage regulator
- 50Ω input and Output Impedance
- Lead-free 260°C / RoHS / Halogen-free
- 24 Pin 5x7.5*0.89mm Package

General Description

The TQM7M9053 is a fully matched multimode multiband Power Amplifier Module that supports Quad-band GSM/EDGE Linear, W/CDMA & LTE Band 1, and low band WCDMA/LTE (externally tuned for either Band 5 or Band 8). The GSM PA output power is controlled by the input power coming from the transceiver in both GMSK and 8PSK modes.

The 2-Gain state WCDMA PA operates in HPM and MPM to maximize talk time over the entire range of operating conditions. It also includes a coupler and built-in regulator, ideal for today's extremely small data enabled phones. The TQM7M9053 is designed on TriQuint's GaAs HBT technology with CuFlip® assembly offering state of the art reliability, temperature stability and ruggedness. Its RF performance meets the stringent linearity requirements for multi-mode operation.

Functional Block Diagram

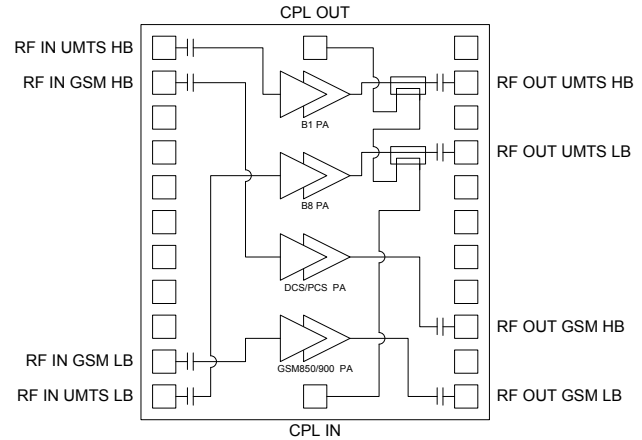

Ordering Information

Part No.	Description
TQM7M9053	QB EDGE+ Tri-Band WCDMA MM PA

Standard T/R size = 2,500 pieces on a 7" reel.