

Silicon Piezoresistive Relative Pressure Sensor

KPY 32-RK

Features

- Low pressure and temperature hysteresis
- Fast response
- High sensitivity and linearity
- Fatigue free monocrystalline silicon diaphragm giving high load cycle stability
- High long term stability
- Provided for further fabrication, protection cap

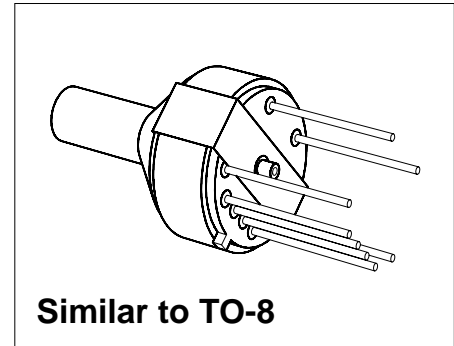

Type and Marking	Symbol	Pressure Range	Unit	Ordering Code
KPY 32-RK	$P_0 \dots P_N$	0 ... 0.06	bar	Q62705-K266

Pin Configuration

1	$-V_{IN}$
2	$-V_{OUT}$
3	Not connected
4	Temperature sensor (typ. $R_{25} = 2 \text{ k}\Omega$)
5	Temperature sensor
6	Shielding, to be connected to $+V_{IN}$
7	$+V_{IN}$
8	$+V_{OUT}$

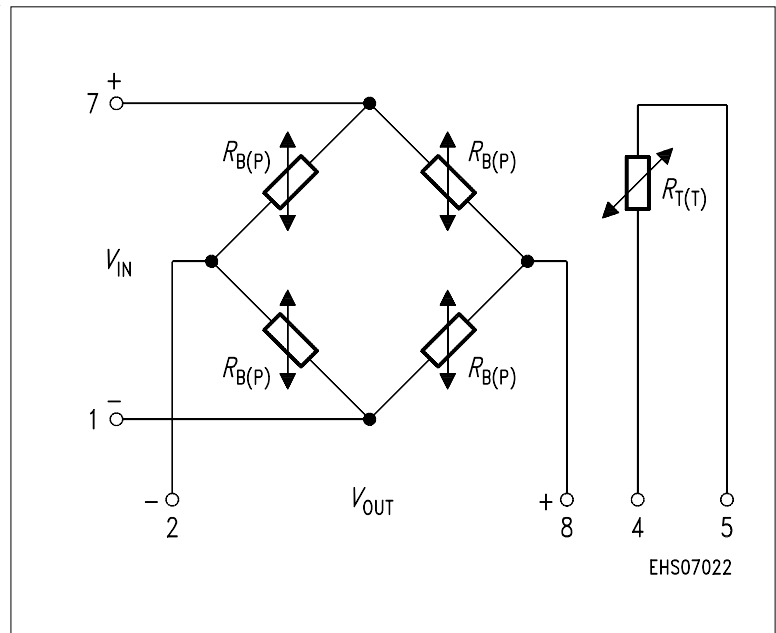

Absolute Maximum Ratings

Parameter	Symbol	Limit Values	Unit
Pressure overload	P_{MAX}	± 0.6	bar
Operating temperature range	T_A	$-40 \dots +125$	$^{\circ}\text{C}$
Storage temperature range	T_{stg}	$-50 \dots +150$	$^{\circ}\text{C}$
Supply voltage	V_{IN}	12	V

Electrical Characteristics

at $T_A = 25^{\circ}\text{C}$ and $V_{IN} = 5\text{ V}$, unless otherwise specified.

Parameter	Symbol	Limit Values			Unit
		min.	typ.	max.	
Bridge resistance	R_B	4	–	8	k Ω
Sensitivity	s	100.0	220.0	–	mV/Vbar
Output voltage	V_{fin}	30.0	66.0	–	mV
Offset voltage $P = P_0$	V_0	– 25	–	+ 25	mV
Linearity error (Best fit straight line) $P = P_0 \dots P_N$	F_L	–	± 0.3	± 2.0	% V_{fin}
Pressure hysteresis $P_1 = P_0, P_2 = P_N, P_3 = P_0$	P_H	–	± 0.1	–	% V_{fin}

Electrical Characteristics

at $T_1 = 25^{\circ}\text{C}$, $T_2 = 125^{\circ}\text{C}$, $T_3 = 25^{\circ}\text{C}$ and $V_{IN} = 5\text{ V}$, unless otherwise specified.

Parameter	Symbol	Limit Values			Unit
		min.	typ.	max.	
Temperature coefficient of V_{fin}	$TC_{V_{fin}}$	– 0.19	–	– 0.11	%/K
Temperature coefficient of V_0	TC_{V_0}	– 0.06	–	+ 0.06	%/K
Temperature coefficient of R_B	TC_{R_B}	–	+ 0.095	–	%/K
Temperature hysteresis of V_0, V_{fin}	TH	– 0.7	–	+ 0.7	% v. V_{fin}

Package Outline

Similar to TO-8

Basic Component

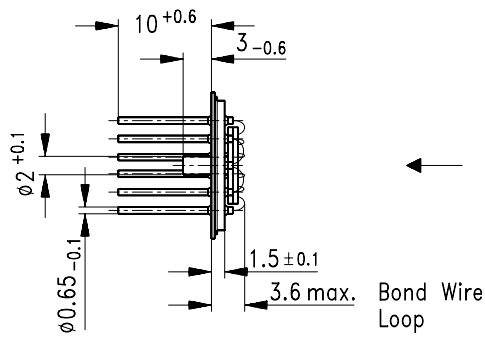

View on Chip

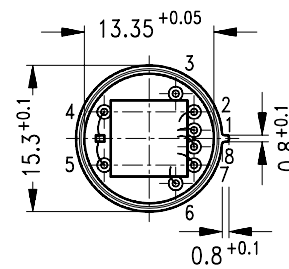

Component Delivery Form

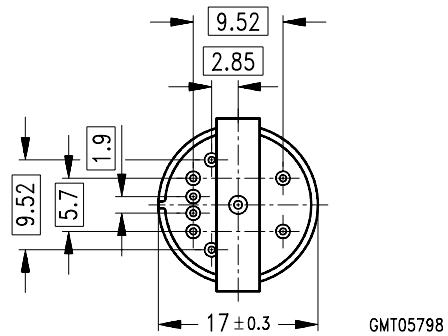
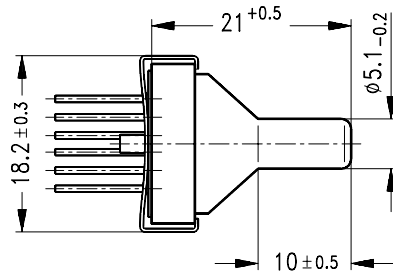

Weight approx. 2.5 g

Dimensions in mm

Exterior Packaging

I.e. tubes, trays, boxes are shown in our Data Book "Package Information".