



RADIATION HARDENED
HIGH POWER
OP-AMP

106RH

FEATURES:

- Manufactured using  Space Qualified RH101 Die
- Radiation Hardened to 100 Krads(Si) (Method 1019.7 Condition A)
- High Output Current - 2 Amps Peak
- Low Power Consumption-Class C Design
- Programmable Current Limit
- Rad Hard Design
- Output Short Circuit Capability
- Rad Hard Replacement for MSK0021FP
- Available to DLA SMD 5962R11228
- Functionally Equivalent Non Rad Hard Device MSK0021FP

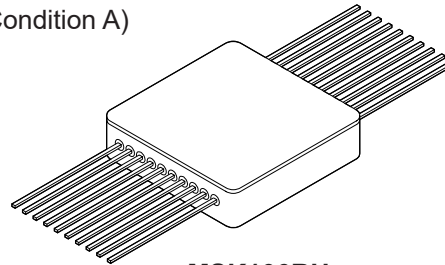

MSK106RH

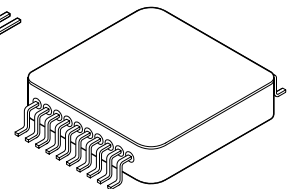

MSK106RHG

DESCRIPTION:

The MSK106RH is a Radiation Hardened Class C power operational amplifier. This amplifier offers large output currents, making it an excellent choice for motor drive circuits. The amplifier and load can be protected from fault conditions through the use of internal current limit circuitry that can be user programmed with two external resistors. These devices are also compensated with a single external capacitor. The MSK106RH is packaged in a 20 pin hermetic metal flatpack that is available with straight or gull wing leads.

EQUIVALENT SCHEMATIC

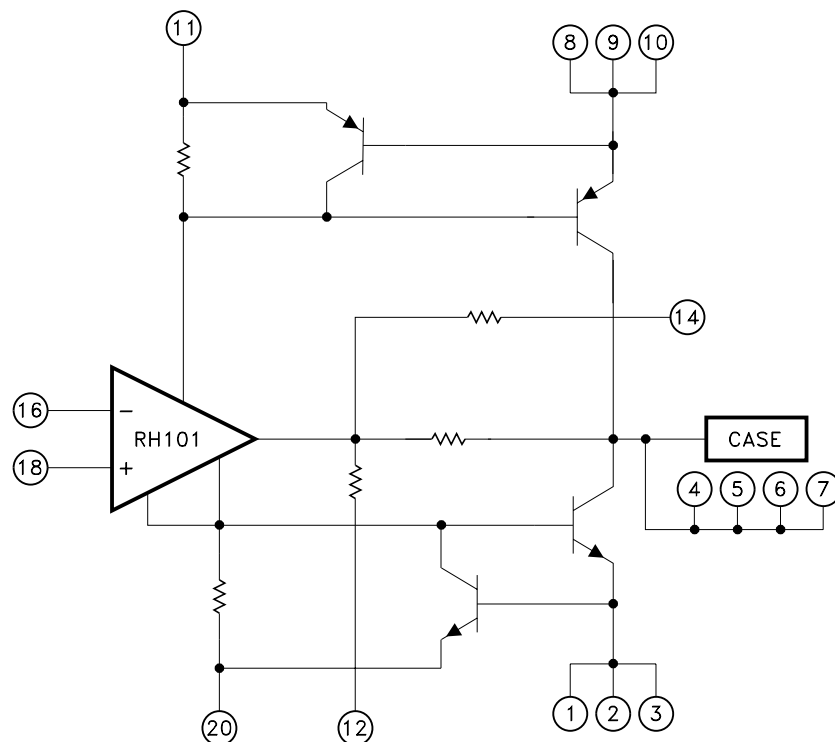

PIN-OUT INFORMATION

1	ISC-	20	-VCC
2	ISC-	19	NC
3	ISC-	18	+VIN
4	VOUT	17	NC
5	VOUT	16	-VIN
6	VOUT	15	NC
7	VOUT	14	Compensation
8	ISC+	13	NC
9	ISC+	12	GND
10	ISC+	11	+VCC

CASE IS ALSO VOUT

TYPICAL APPLICATIONS

- Servo Amplifier
- Motor Driver
- Audio Amplifier
- Programmable Power Supply

ABSOLUTE MAXIMUM RATINGS

⑧

$\pm V_{CC}$	Supply Voltage.....	$\pm 22V$	T_{ST}	Storage Temperature Range.....	$-65^{\circ}C$ to $+150^{\circ}C$
I_{OUT}	Peak Output Current.....	$2A$	T_{LD}	Lead Temperature Range (10 Seconds).....	$300^{\circ}C$
V_{IN}	Differential Input Voltage.....	$\pm 30V$	T_J	Junction Temperature.....	$150^{\circ}C$
V_{IN}	Common mode Input Voltage.....	$\pm 15V$	T_C	Case Operating Temperature Range MSK106K/H RH.....	$-55^{\circ}C$ to $+125^{\circ}C$
R_{TH}	Thermal Resistance.....	$6.0^{\circ}C/W$		MSK106RH.....	$-40^{\circ}C$ to $+85^{\circ}C$
	Junction to Case (@ $125^{\circ}C$)				

ELECTRICAL SPECIFICATIONS

Parameter	Test Conditions ⑨	Group A Subgroup	MSK106K/H RH			MSK106 RH			Units
			Min.	Typ.	Max.	Min.	Typ.	Max.	
STATIC									
Supply Voltage Range ②		-	± 5	± 15	± 22	± 5	± 15	± 22	V
Quiescent Current	$V_{IN} = 0V$	1	-	± 1.7	± 3.5	-	± 1.7	± 4.0	mA
		2,3	-	-	± 7.5	-	-	-	mA
Power Consumption ②	$V_{IN} = 0V$	1,2,3	-	75	225	-	75	225	mW
INPUT									
Input Offset Voltage	$V_{IN} = 0V$	1	-	± 0.5	± 3.0	-	± 0.5	± 5.0	mV
		2, 3	-	± 2.0	± 5.0	-	-	-	mV
Input Bias Current	$V_{CM} = 0V$ Either Input	1	-	± 100	± 500	-	± 150	± 500	nA
		2, 3	-	± 0.4	± 2.0	-	-	-	μA
Input Offset Current	$V_{CM} = 0V$	1	-	± 2.0	± 100	-	± 2.0	± 300	nA
		2,3	-	-	± 300	-	-	-	nA
Input Capacitance ③	$F = DC$	-	-	3	-	-	3	-	pF
Input Resistance ②	$F = DC$	-	0.3	1.0	-	0.3	1.0	-	$M\Omega$
Common Mode Rejection Ratio	$F = 10Hz$ $V_{CM} = \pm 10V$	4	70	90	-	70	90	-	dB
		5,6	70	90	-	-	-	-	dB
Power Supply Rejection Ratio	$V_{CC} = \pm 5V$ to $\pm 15V$	1	80	95	-	80	95	-	dB
		2,3	80	-	-	-	-	-	dB
Input Noise Voltage ③	$F = 10Hz$ to $10KHz$	-	-	5	-	-	5	-	μV_{RMS}
OUTPUT									
Output Voltage Swing	$R_L = 100\Omega$ $F = 100Hz$	4	± 13.5	± 14	-	± 13.0	± 14	-	V
		5,6	± 13.5	± 14	-	-	-	-	V
Output Short Circuit Current	$R_{SC} = 0.5\Omega$ $V_{OUT} = MAX$ $R_{SC} = 5\Omega$ $V_{OUT} = GND$	4	± 11	± 12	-	± 10.5	± 12	-	V
		4	0.8	1.2	1.6	0.7	1.2	1.7	A
Settling Time ③	0.1% 2V step	4	50	150	250	50	150	250	mA
		-	-	4	-	-	4	-	μS
TRANSFER CHARACTERISTICS									
Slew Rate	$V_{OUT} = \pm 10V$ $R_L = 10\Omega$	4	1.2	1.4	-	1.0	1.4	-	$V/\mu S$
		4	1.1	-	-	1.1	-	-	$V/\mu S$
Open Loop Voltage Gain	$F = 10Hz$ $R_L = 1K\Omega$	4	100	105	-	100	105	-	dB
		5,6	88	96	-	-	-	-	dB
Transition Times	1V to 2V P Rise and Fall	4	-	0.8	1.0	-	0.8	1.2	μS
		4	-	1.0	1.2	-	1.0	1.2	μS
Overshoot	0V to 1V P Small Signal	4	-	5	20	-	5	20	%

NOTES:

- ① Unless otherwise specified, $\pm V_{CC} = \pm 15V$, $CC = 3000pF$.
- ② Guaranteed by design but not tested.
- ③ Typical parameters are representative of actual device performance but are for reference only.
- ④ Industrial grade devices shall be tested to subgroups 1 and 4 unless otherwise specified.
- ⑤ Military grade devices (K/H suffix) shall be 100% tested to subgroups 1, 2, 3 and 4.
Subgroup 1, 4 $T_A = +25^{\circ}C$
2, 5 $T_A = +125^{\circ}C$
3, 6 $T_A = -55^{\circ}C$
- ⑥ Reference DLA SMD 5962R11228 for electrical specifications for devices purchased as such.
- ⑦ Subgroup 5 and 6 testing available upon request.
- ⑧ Continuous operation at or above absolute maximum ratings may adversely effect the device performance and/or life cycle.
- ⑨ Pre and post irradiation limits at $25^{\circ}C$, up to 100Krad TID, are identical unless otherwise specified.

APPLICATION NOTES

HEAT SINKING

To select the correct heat sink for your application, refer to the thermal model and governing equation below.

Thermal Model:

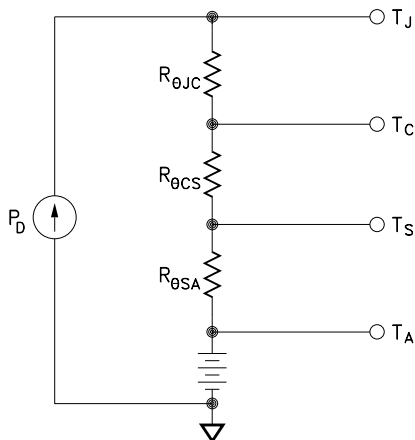

Governing Equation:

$$T_J = P_D \times (R_{\theta JC} + R_{\theta CS} + R_{\theta SA}) + T_A$$

Where

T_J	=	Junction Temperature
P_D	=	Total Power Dissipation
$R_{\theta JC}$	=	Junction to Case Thermal Resistance
$R_{\theta CS}$	=	Case to Heat Sink Thermal Resistance
$R_{\theta SA}$	=	Heat Sink to Ambient Thermal Resistance
T_C	=	Case Temperature
T_A	=	Ambient Temperature
T_S	=	Sink Temperature

Example:

In our example the amplifier application requires the output to drive a 10 volt peak sine wave across a 10 ohm load for 1 amp of output current. For a worst case analysis we will treat the 1 amp peak output current as a D.C. output current. The power supplies are ± 15 VDC.

1.) Find Power Dissipation

$$\begin{aligned} P_D &= [(\text{quiescent current}) \times (+VCC - (-VCC))] + \\ &\quad [(V_S - V_O) \times I_{OUT}] \\ &= (3.5 \text{ mA}) \times (30V) + (5V) \times (1A) \\ &= 0.1W + 5W \\ &= 5.1W \end{aligned}$$

2.) For conservative design, set $T_J = +125^\circ\text{C}$.

3.) For this example, worst case $T_A = +25^\circ\text{C}$.

4.) $R_{\theta JC} = 6.0^\circ\text{C/W}$

5.) Rearrange governing equation to solve for $R_{\theta SA}$:

$$\begin{aligned} R_{\theta SA} &= (T_J - T_A) / P_D - (R_{\theta JC}) - (R_{\theta CS}) \\ &= (125^\circ\text{C} - 25^\circ\text{C}) / 5.1W - (6.0^\circ\text{C/W}) - (0.15^\circ\text{C/W}) \\ &= 13.5^\circ\text{C/W} \end{aligned}$$

The heat sink in this example must have a thermal resistance of no more than 13.5°C/W to maintain a junction temperature of less than $+125^\circ\text{C}$

CURRENT LIMIT

The MSK106RH has an on-board current limit scheme designed to limit the output drivers anytime output current exceeds a predetermined limit. The following formula may be used to determine the value of the current limit resistance necessary to establish the desired current limit.

$$R_{sc} = \frac{0.7V}{I_{sc}}$$

Current Limit Connection:

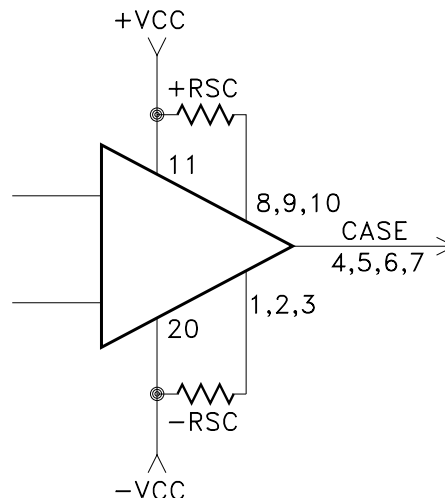

See "Application Circuits" in this data sheet for additional information on current limit connections.

POWER SUPPLY BYPASSING

Both the negative and the positive power supplies must be effectively decoupled with a high and low frequency bypass circuit to avoid power supply induced oscillation. An effective decoupling scheme consists of a 0.1 microfarad ceramic capacitor in parallel with a 4.7 microfarad tantalum capacitor from each power supply pin to ground. It is also a good practice with high power op-amps, such as the MSK106RH, to place a 30-50 microfarad capacitor with a low effective series resistance, in parallel with the other two power supply decoupling capacitors. This capacitor will eliminate any peak output voltage clipping which may occur due to poor power supply load regulation. All power supply decoupling capacitors should be placed as close to the package power supply pins as possible.

TOTAL DOSE RADIATION TEST PERFORMANCE

Radiation performance curves for TID testing have been generated for all radiation testing performed by MSK. These curves show performance trends throughout the TID test process and can be located in the MSK106RH radiation test report. The complete radiation test report is available in the RAD HARD PRODUCTS section on the MSK website.

APPLICATION CIRCUITS

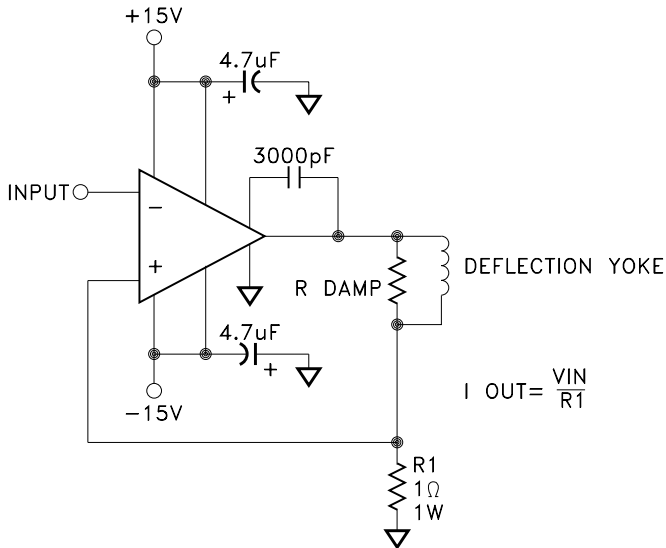

CRT DEFLECTION YOKE DRIVER

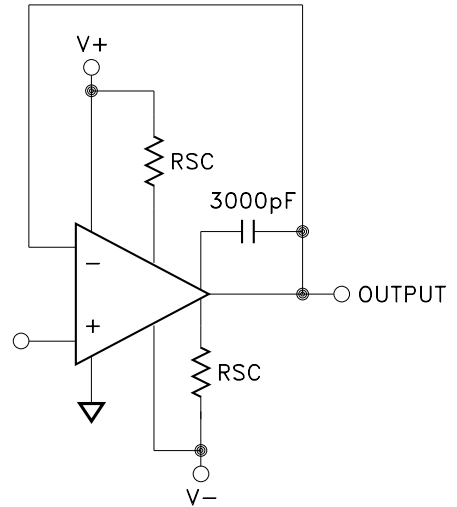

UNITY GAIN CIRCUIT WITH SHORT CIRCUIT LIMITING

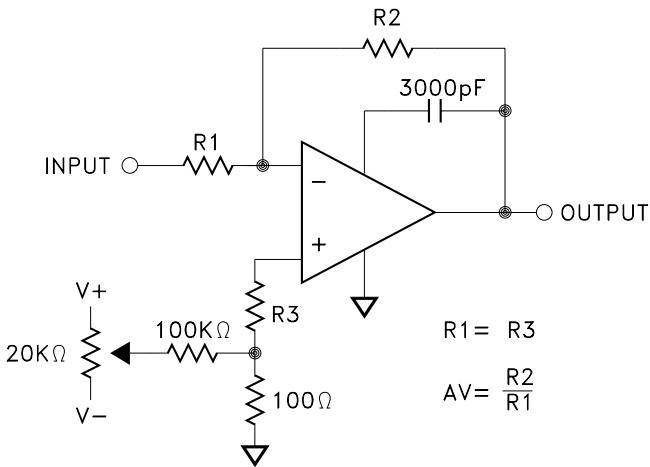

OFFSET VOLTAGE NULL CIRCUIT

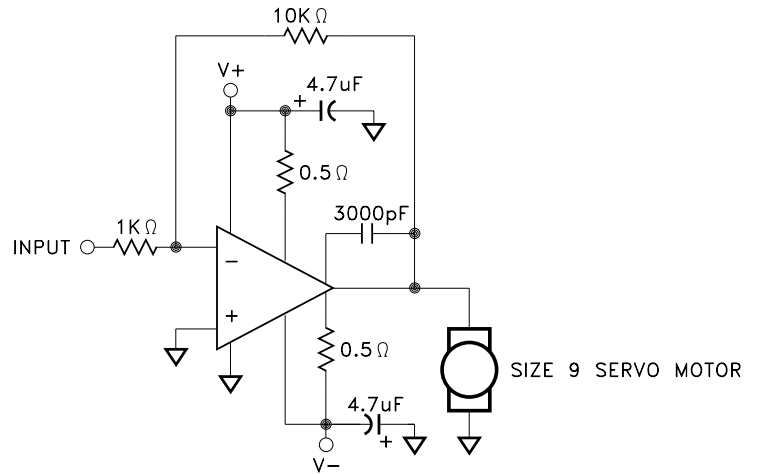

DC SERVO AMPLIFIER

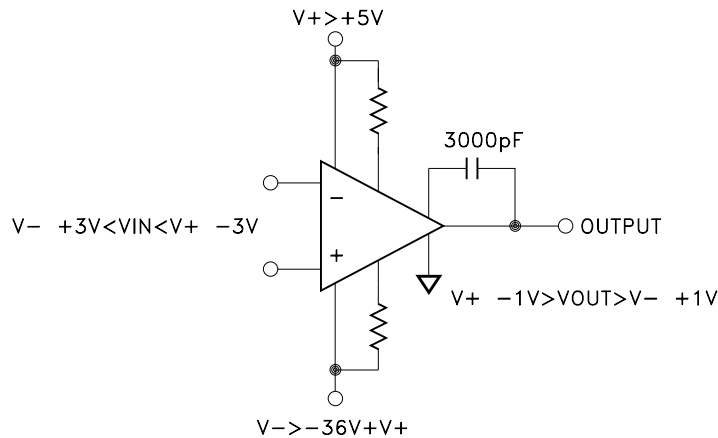

NON SYMMETRICAL SUPPLIES

TYPICAL PERFORMANCE CURVES

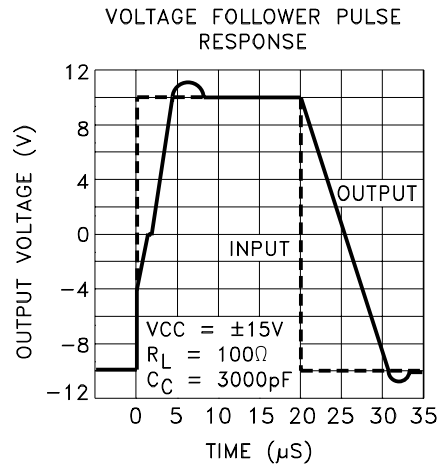
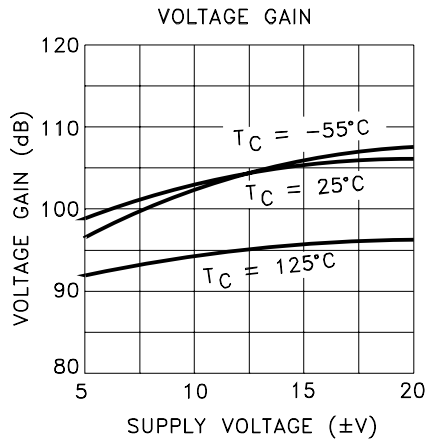
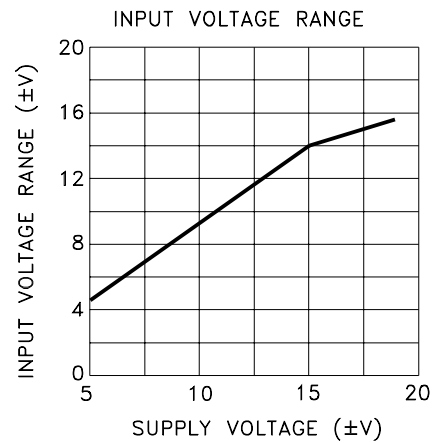
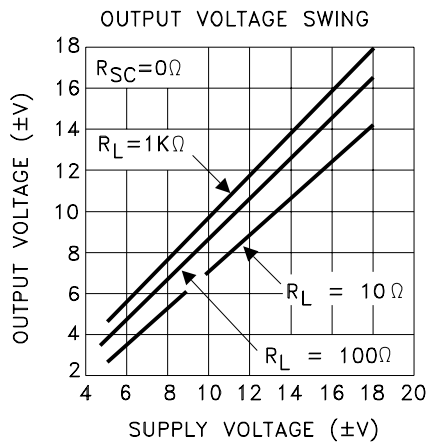
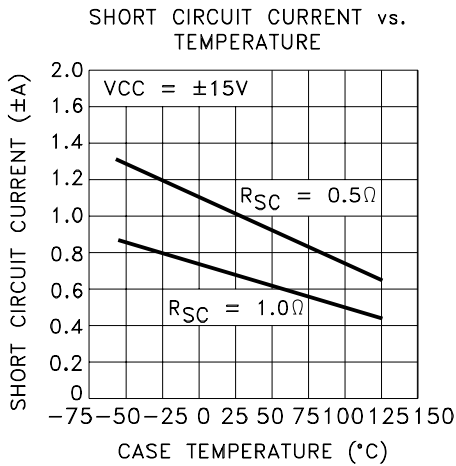
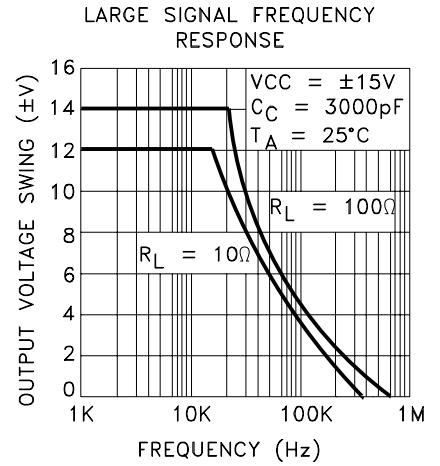
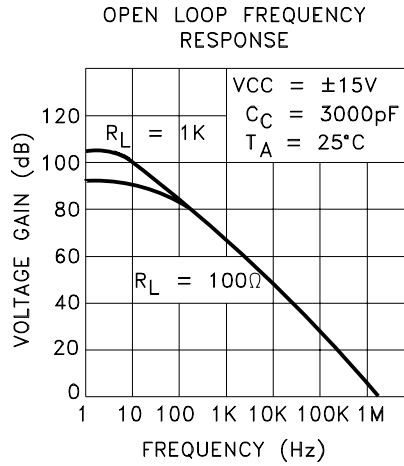
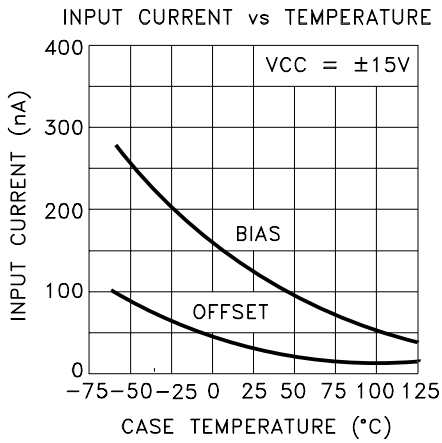

MECHANICAL SPECIFICATIONS

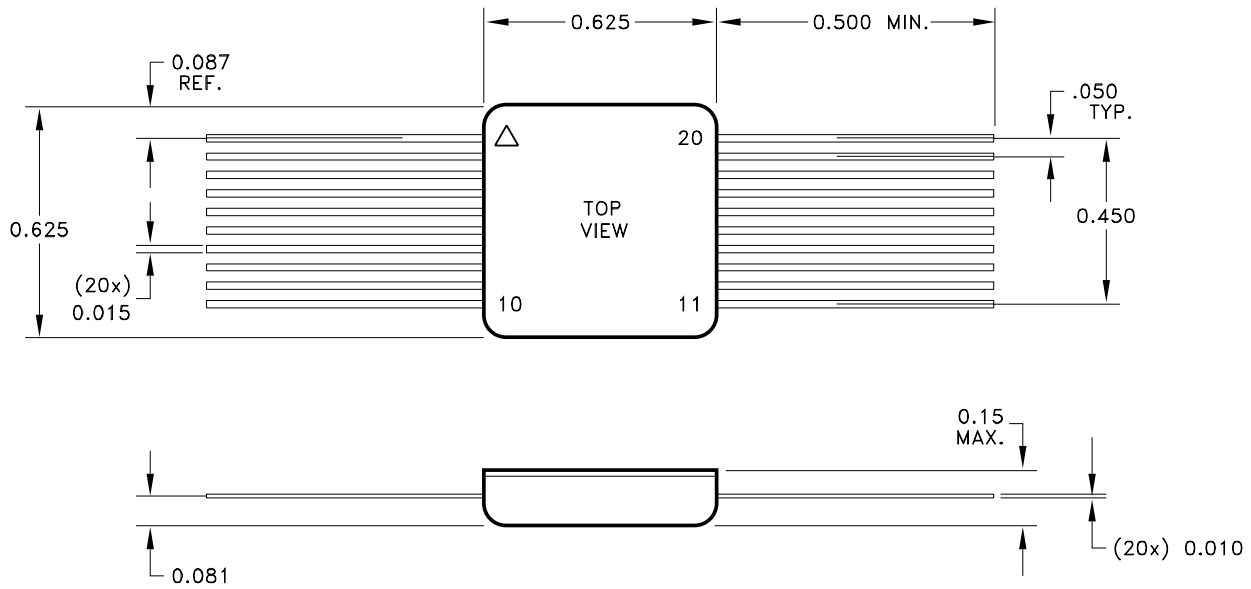

WEIGHT= 4.1 GRAMS TYPICAL

NOTE: ALL DIMENSIONS ARE ± 0.010 INCHES UNLESS OTHERWISE LABELED.
ESD Triangle indicates pin 1.

ORDERING INFORMATION

Part Number	Screening Level
MSK106RH	INDUSTRIAL
MSK106HRH	MIL-PRF-38534 CLASS H
MSK106KRH	MIL-PRF-38534 CLASS K
5962R11228	DLA SMD

MECHANICAL SPECIFICATIONS CONTINUED

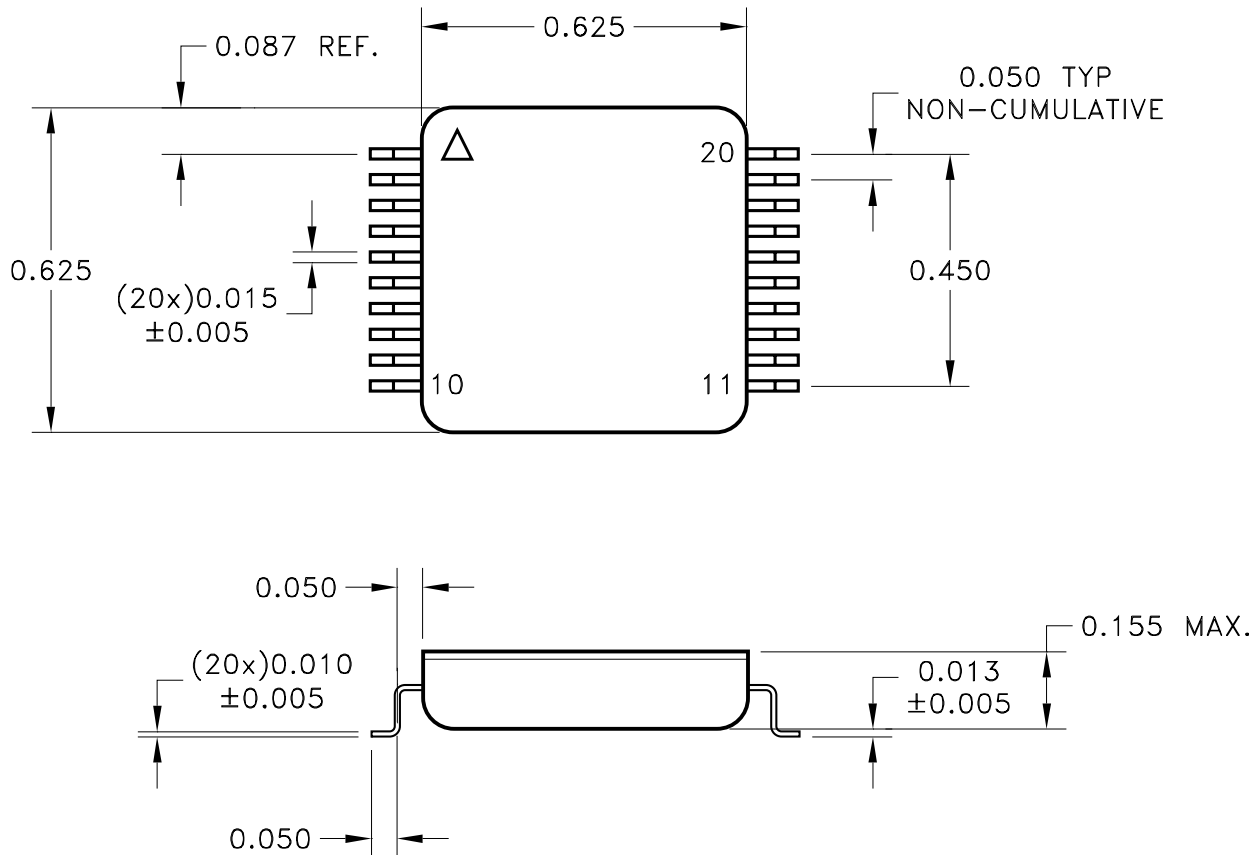

WEIGHT= 4.0 GRAMS TYPICAL

NOTE: ALL DIMENSIONS ARE ± 0.010 INCHES UNLESS OTHERWISE LABELED.
ESD Triangle indicates pin 1.

ORDERING INFORMATION

Part Number	Screening Level
MSK106RHG	INDUSTRIAL
MSK106HRHG	MIL-PRF-38534 CLASS H
MSK106KRHG	MIL-PRF-38534 CLASS K
5962R11228	DLA SMD

REVISION HISTORY

REV	STATUS	DATE	DESCRIPTION
K	Released	08/17	Editorial in Electrical Spec; update format.

ANAREN, MSK Products
www.anaren.com/msk

The information contained herein is believed to be accurate at the time of printing. Anaren, MSK products reserves the right to make changes to its products or specifications without notice, however and assumes no liability for the use of its products.
Please visit our website for the most recent revision of this datasheet.