

Digital Output with Position Feedback

FB2212BR



- 1 digital output, 2 digital inputs
- Inputs and output Ex ia
- Installation in suitable enclosures in Zone 1
- Module can be exchanged under voltage (hot swap)
- Positive or negative logic selectable
- Simulation mode for service operations (forcing)
- Line fault detection (LFD)
- Permanently self-monitoring
- Output with watchdog



Function

The digital output features 1 output with 2 feedback inputs. The device can be used to switch solenoids, sounders, or indicators (without line fault detection) in the field. Furthermore, the device accepts digital input signals of NAMUR sensors or mechanical contacts from the field. Open and short-circuit line faults are detected. The intrinsically safe inputs and the output are galvanically isolated from the bus and the power supply.

Connection

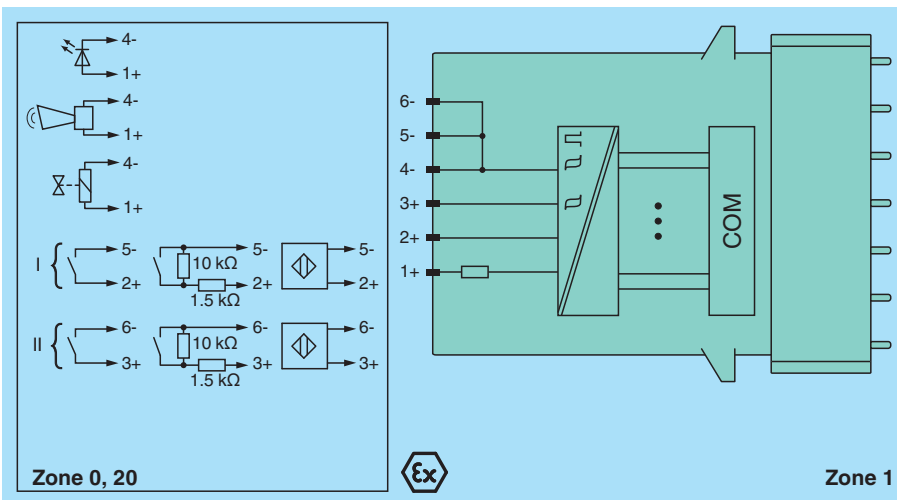

Technical Data

Slots			
Occupied slots	1		
Supply			
Connection	backplane bus		
Rated voltage	U_r	12 V DC , only in connection with the power supplies FB92**	
Power dissipation	1.3 W		
Power consumption	1.8 W		
Internal bus			
Connection	backplane bus		
Interface	manufacturer-specific bus to standard com unit		
Digital input			

Release date: 2021-11-16 Date of issue: 2021-11-16 Filename: 302481_eng.pdf

Refer to "General Notes Relating to Pepperl+Fuchs Product Information".

Pepperl+Fuchs Group
www.pepperl-fuchs.com

USA: +1 330 486 0002
pa-info@us.pepperl-fuchs.com

Germany: +49 621 776 2222
pa-info@de.pepperl-fuchs.com

Singapore: +65 6779 9091
pa-info@sg.pepperl-fuchs.com

PF PEPPERL+FUCHS

Technical Data

Number of channels		2
Sensor interface		
Connection		NAMUR sensor
Connection [2]		volt-free contact
Connection [3]		active binary signal 24 V DC
Connection		channel I: 2+, 5-; channel II: 3+, 6-
Rated values		acc. to EN 60947-5-6 (NAMUR)
Switching point/switching hysteresis		1.2 ... 2.1 mA / ± 0.2 mA
Internal resistor	R_i	1 k Ω
Line fault detection		can be switched on/off for each channel via configuration tool
Connection		mechanical switch with additional resistors (see connection diagram) proximity switches without additional wiring
Short-circuit		< 360 Ω
Open-circuit		< 0.35 mA
Minimum pulse duration		1 ms
Digital output		
Number of channels		1
Suitable field devices		
Field device		Solenoid Valve
Field device [2]		audible alarm
Field device [3]		visual alarm
Connection		channel I: 1+, 4-
Open loop voltage	U_s	25.3 V
Current limit	I_{max}	53 mA
Internal resistor	R_i	329 Ω
Line fault detection		can be switched on/off for each channel via configuration tool , also when turned off (every 2.5 s the valve is turned on for 2 ms)
Short-circuit		< 170 Ω
Open-circuit		> 3.5 k Ω
Response time		20 ms (depending on bus cycle time)
Watchdog		within 0.5 s the device goes in safe state, e.g. after loss of communication
Indicators/settings		
LED indication		LED green: supply LED red: output line fault LED yellow: status output
Coding		optional mechanical coding via front socket
Directive conformity		
Electromagnetic compatibility		
Directive 2014/30/EU		EN 61326-1:2013
Conformity		
Electromagnetic compatibility		NE 21
Degree of protection		IEC 60529
Environmental test		EN 60068-2-14
Shock resistance		EN 60068-2-27
Vibration resistance		EN 60068-2-6
Damaging gas		EN 60068-2-42
Relative humidity		EN 60068-2-56
Ambient conditions		
Ambient temperature		-20 ... 60 °C (-4 ... 140 °F)
Storage temperature		-25 ... 85 °C (-13 ... 185 °F)
Relative humidity		95 % non-condensing
Shock resistance		shock type I, shock duration 11 ms, shock amplitude 15 g, number of shocks 18
Vibration resistance		frequency range 10 ... 150 Hz; transition frequency: 57.56 Hz, amplitude/acceleration ± 0.075 mm/1 g; 10 cycles frequency range 5 ... 100 Hz; transition frequency: 13.2 Hz amplitude/acceleration ± 1 mm/0.7 g; 90 minutes at each resonance

Release date: 2021-11-16 Date of issue: 2021-11-16 Filename: 302481_eng.pdf

Refer to "General Notes Relating to Pepperl+Fuchs Product Information".

 Pepperl+Fuchs Group
www.pepperl-fuchs.com

 USA: +1 330 486 0002
pa-info@us.pepperl-fuchs.com

 Germany: +49 621 776 2222
pa-info@de.pepperl-fuchs.com

 Singapore: +65 6779 9091
pa-info@sg.pepperl-fuchs.com

 **PEPPERL+FUCHS**

Technical Data

Damaging gas		designed for operation in environmental conditions acc. to ISA-S71.04-1985, severity level G3
Mechanical specifications		
Degree of protection		IP20 (module) , a separate housing is required acc. to the system description
Connection		removable front connector with screw flange (accessory) wiring connection via spring terminals (0.14 ... 1.5 mm ²) or screw terminals (0.08 ... 1.5 mm ²)
Mass		approx. 350 g
Dimensions		28 x 107 x 132 mm (1.1 x 4.2 x 5.2 inch)
Data for application in connection with hazardous areas		
EU-type examination certificate		PTB 97 ATEX 1074 U
Marking		Ⓜ II 2(1) G Ex d [ia Ga] IIC Gb Ⓜ II (1) D [Ex ia Da] IIIC
Input		
Voltage	U _o	14.1 V
Current	I _o	16 mA
Power	P _o	55 mW (linear characteristic)
Internal capacitance	C _i	1.65 nF
Output		
Voltage	U _o	27.83 V
Current	I _o	108.2 mA
Power	P _o	751 mW
Internal capacitance	C _i	1.65 nF
Galvanic isolation		
Input/power supply, internal bus		safe electrical isolation acc. to EN 60079-11, voltage peak value 375 V
Output/power supply, internal bus		safe electrical isolation acc. to EN 60079-11, voltage peak value 375 V
Directive conformity		
Directive 2014/34/EU		EN IEC 60079-0:2018+AC:2020 EN 60079-1:2014 EN 60079-11:2012
International approvals		
ATEX approval		PTB 97 ATEX 1075 ; PTB 97 ATEX 1074 U
General information		
System information		The module has to be mounted in appropriate backplanes and housings (FB92**) in Zone 1, 2, 21, 22 or outside hazardous areas (gas or dust). Here, observe the corresponding EC-type examination certificate.
Supplementary information		EC-Type Examination Certificate, Statement of Conformity, Declaration of Conformity, Attestation of Conformity and instructions have to be observed where applicable. For information see www.pepperl-fuchs.com .

Assembly

Front view

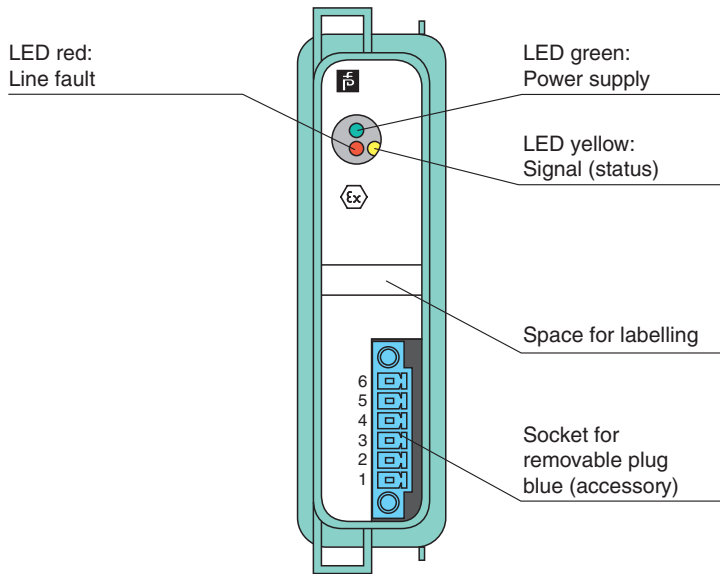

Characteristic Curve

Load calculation

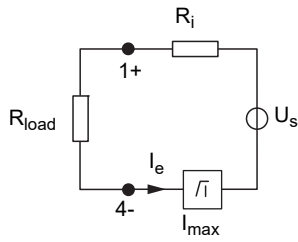

R_{load} = Field loop resistance
 $U_e = U_s - R_i \times I_e$
 $I_e = U_s / (R_i + R_{load})$

Output characteristics

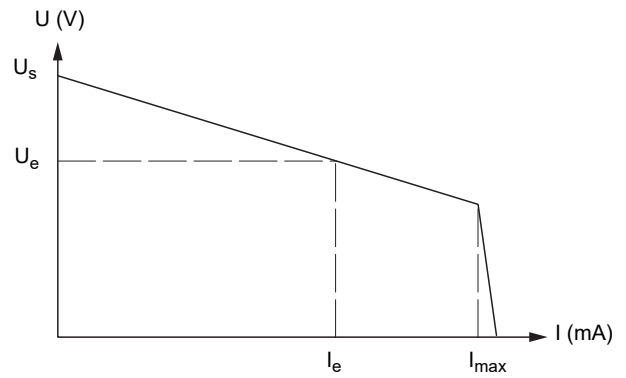

Release date: 2021-11-16 Date of issue: 2021-11-16 Filename: 302481_eng.pdf

Refer to "General Notes Relating to Pepperl+Fuchs Product Information".