

PC817X

四脚光电耦合器，晶体管输出



概述

PC817X是一款由一个发光二极管和一个光电晶体管组成的光电耦合器。四引脚封装，三种形式（DIP、DIP-M、SMD）。

特性

- 电流转换比(CTR)范围: 80%~600% ($I_F=5\text{mA}$, $V_{CE}=5\text{V}$)
- 输入-输出隔离电压 ($V_{iso}=5000\text{V rms}$)
- 集电极-发射极击穿电压 $BV_{CEO}\geq 80\text{V}$

应用

- 开关电源，智能电表
- 工业控制，测量仪器
- 办公设备，比如复印机
- 家用电器，比如空调、风扇、热水器等

结构原理图和封装

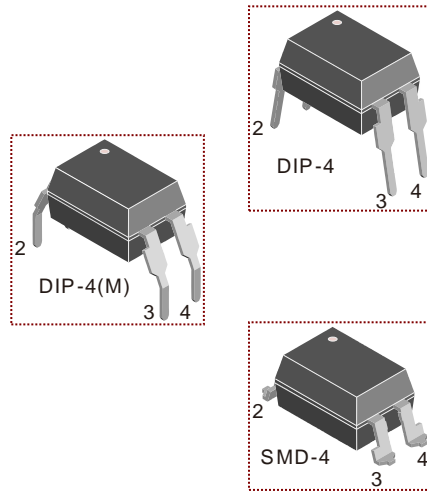
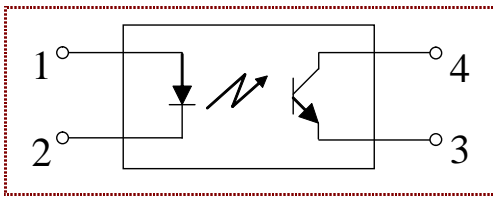

极限参数 ($T_a=25^\circ\text{C}$)

参数		符号	额定值	单位
输入	正向电流	I_F	50	mA
	反向电压	V_R	6	V
	功耗	P_D	70	mW
	额定值降低因子(在 $T_a = 100^\circ\text{C}$ 以上)	P_{DD}	2.9	mW/ $^\circ\text{C}$
	热阻(结-环境)	R_{thJ-A}	325	$^\circ\text{C}/\text{W}$
	热阻(结-壳)	R_{thJ-C}	200	$^\circ\text{C}/\text{W}$
输出	集电极功耗	P_C	150	mW
	集电极电流	I_C	50	mA
	集电极-发射极电压	V_{CEO}	80	V
	发射极-集电极电压	V_{ECO}	6	V
总功耗	P_{tot}	200	mW	
隔离电压	V_{iso}	5000	V _{rms}	
工作温度	T_{opr}	-55~+110	$^\circ\text{C}$	
存储温度	T_{stg}	-55~+125	$^\circ\text{C}$	
焊接温度	T_{sol}	260	$^\circ\text{C}$	

PC817X

四脚光电耦合器，晶体管输出



光电特性 (Ta=25°C)

参数		符号	条件	最小	典型	最大	单位
输入	正向电压	V_F	$I_F=20\text{mA}$	-	1.2	1.4	V
	反向电流	I_R	$V_R=4\text{V}$	-	-	10	μA
	终端电容	C_t	$V=0, f=1\text{kHz}$	-	30	250	pF
输出	集电极暗电流	I_{CEO}	$V_{CE}=20\text{V}$	-	-	100	nA
	集电极-发射极击穿电压	BV_{CEO}	$I_C=0.1\text{mA}, I_F=0$	80	-	-	V
	发射极-集电极击穿电压	BV_{ECO}	$I_E=10\mu\text{A}, I_F=0$	6	-	-	V
传输特性	电流转换比	CTR	$I_F=5\text{mA}, V_{CE}=5\text{V}$	80	-	600	%
	集电极-发射极饱和压降	$V_{CE(sat)}$	$I_F=20\text{mA}, I_C=1\text{mA}$	-	0.1	0.2	V
	隔离电阻	R_{ISO}	DC500V, 40~60% R.H.	5×10^{10}	1×10^{11}	-	Ω
	隔离电容	C_f	$V=0, f=1\text{MHz}$	-	0.6	1.0	pF
	截止频率	F_c	$V_{CE}=5\text{V}, I_C=2\text{mA}, R_L=100\Omega, -3\text{dB}$	-	80	-	kHz
	上升时间	T_r	$V_{CE}=2\text{V}, I_C=2\text{mA}, R_L=100\Omega$	-	4	18	μs
	下降时间	T_f	$V_{CE}=2\text{V}, I_C=2\text{mA}, R_L=100\Omega$	-	3	18	μs

* $CTR=I_C/I_F \times 100\%$

CTR 分档表

分档	A	B	C	D	L	Q	-
CTR	80~160	130~260	200~400	300~600	80~100	100~200	80~600

PC817X

四脚光电耦合器，晶体管输出



印字

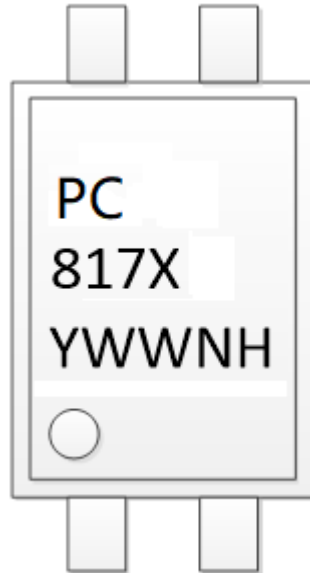

- 印字中的“X”代表产品分档：B、C或D
- 印字中“Y”代表年份：A(2018),B(2019),C(2020)....
- 印字中“WW”代表星期
- 印字中“N”代表星期几
- 印字中的“H”代表无卤：而当产品有卤/无铅时，此处空白

客户订单型号命名规则

PC817X-ZV-WY

X = CTR 分档 (A 或 B 或 C 或 D 或 L 或 Q)

ZV = 框架 (Cu=铜, Fe=铁)

W = 封装形式 (D=DIP, S=SMD, M=DIP M 型)

Y = 树脂 (H=无卤, L=有卤/无铅)

例如：

订单型号	描述	印字
PC817B-Fe-DL	B 档铁框架 DIP 有卤/无铅	PC817B
PC817C-Cu-SH	C 档铜框架 SMD 无卤	PC817C
PC817D-Cu-MH	D 档铜框架 M 型无卤	PC817D

PC817X

四脚光电耦合器，晶体管输出



典型光电特性曲线

Fig.1 正向峰值电流 vs 占空比曲线图

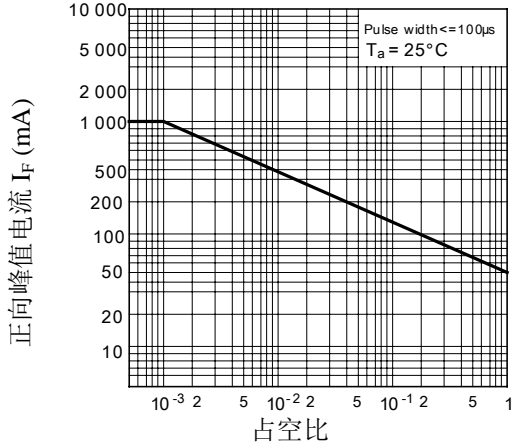

Fig.2 电流转换比 vs 正向电流曲线图

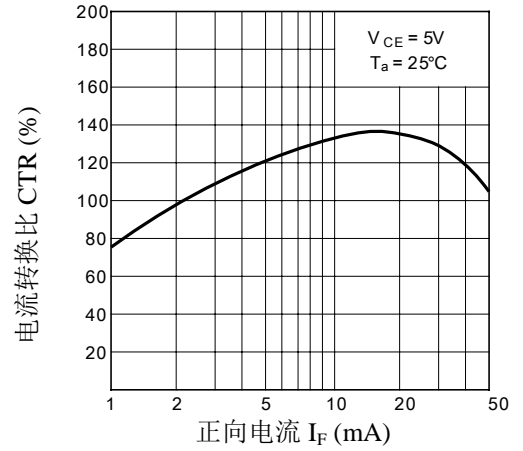

Fig.3 正向电流 vs 正向电压曲线图

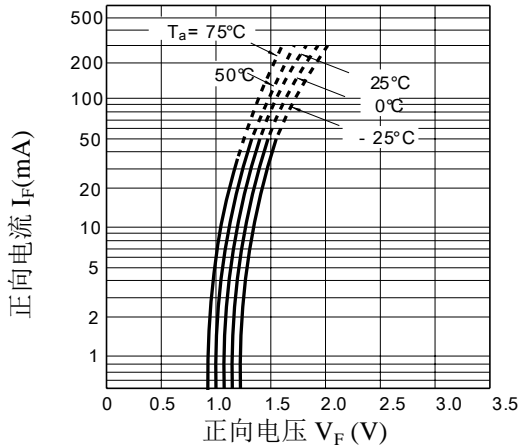

Fig.4 集电极电流 vs 集-发电压曲线图

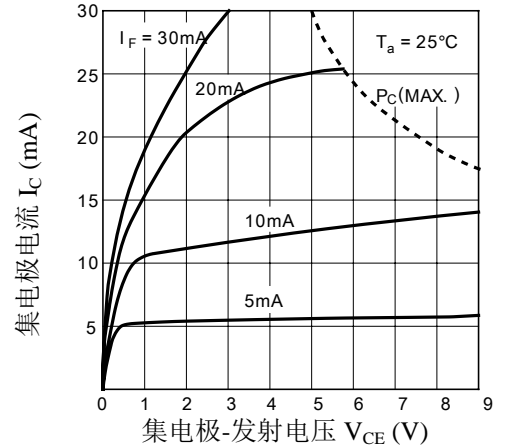

Fig.5 相对电流转换比 vs 环境温度曲线图

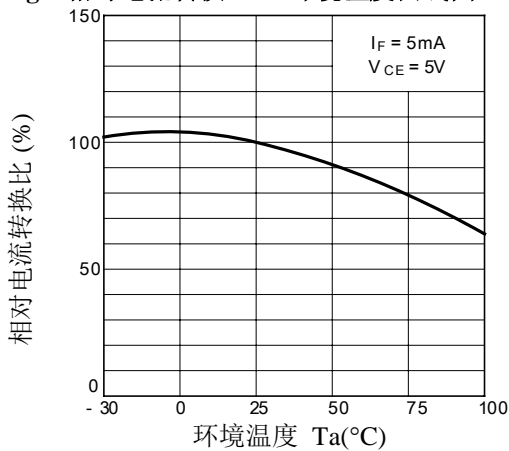
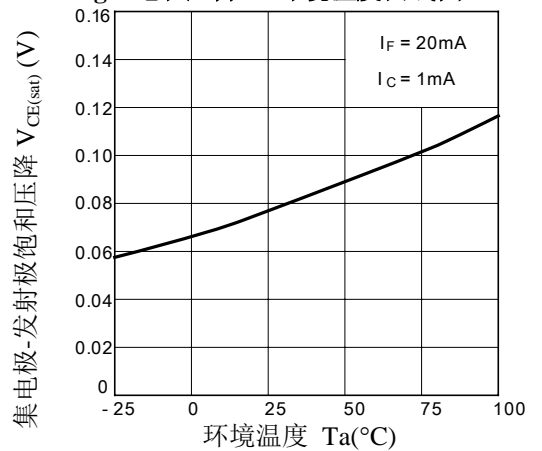

Fig.6 饱和压降 vs 环境温度曲线图



PC817X

四脚光电耦合器，晶体管输出



Fig.7 集电极暗电流 vs 环境温度曲线图

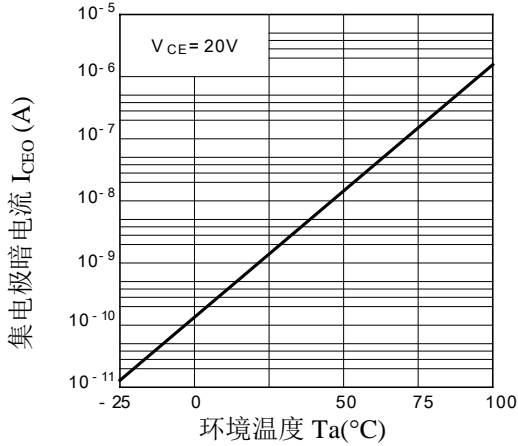

Fig.8 响应时间 vs 负载电阻曲线图

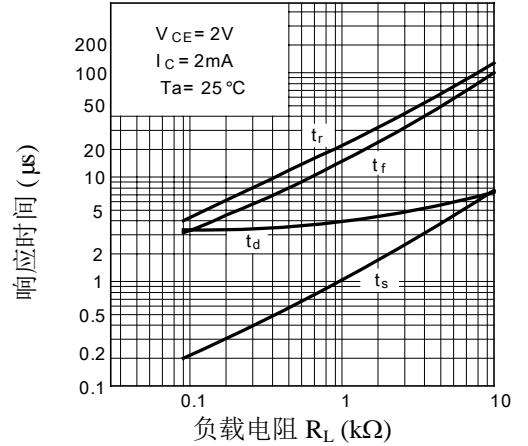

Fig.9 频率响应曲线图

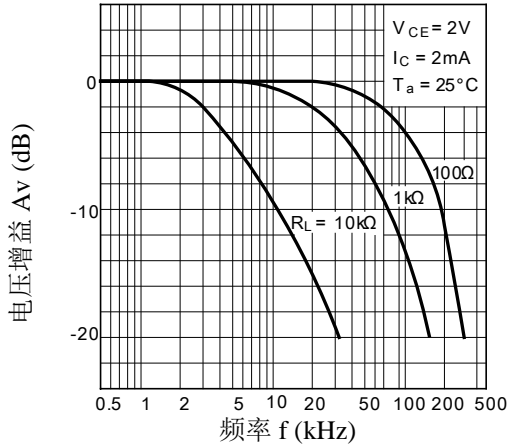
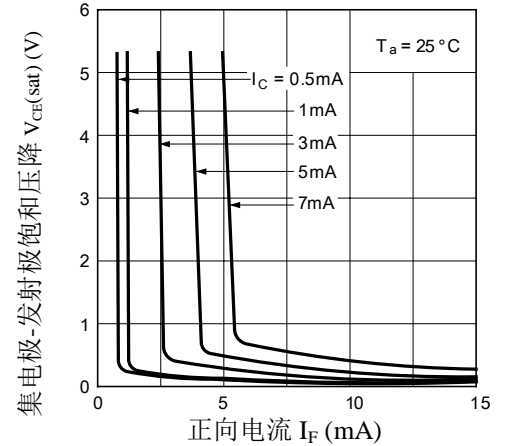
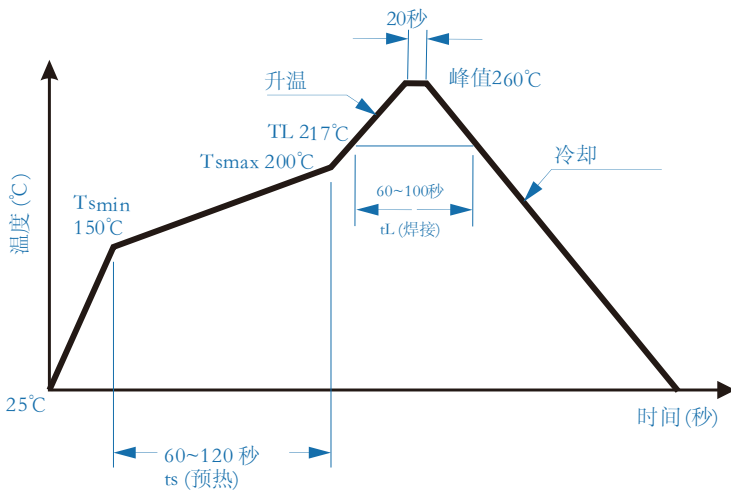

Fig.10 饱和压降 vs 正向电流曲线图



回流焊温度曲线图



PC817X

四脚光电耦合器，晶体管输出



外形尺寸

单位: mm(inch)

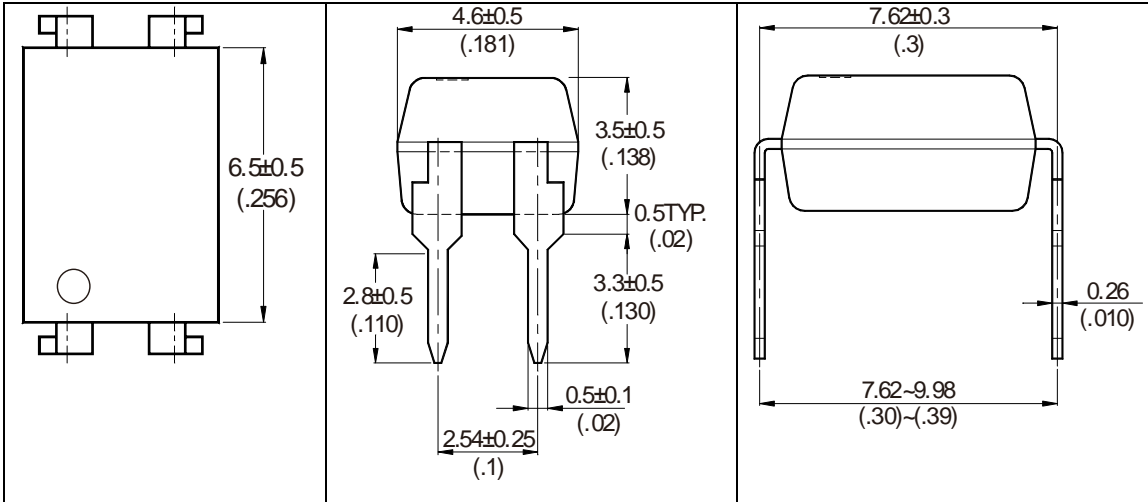

4-pin DIP

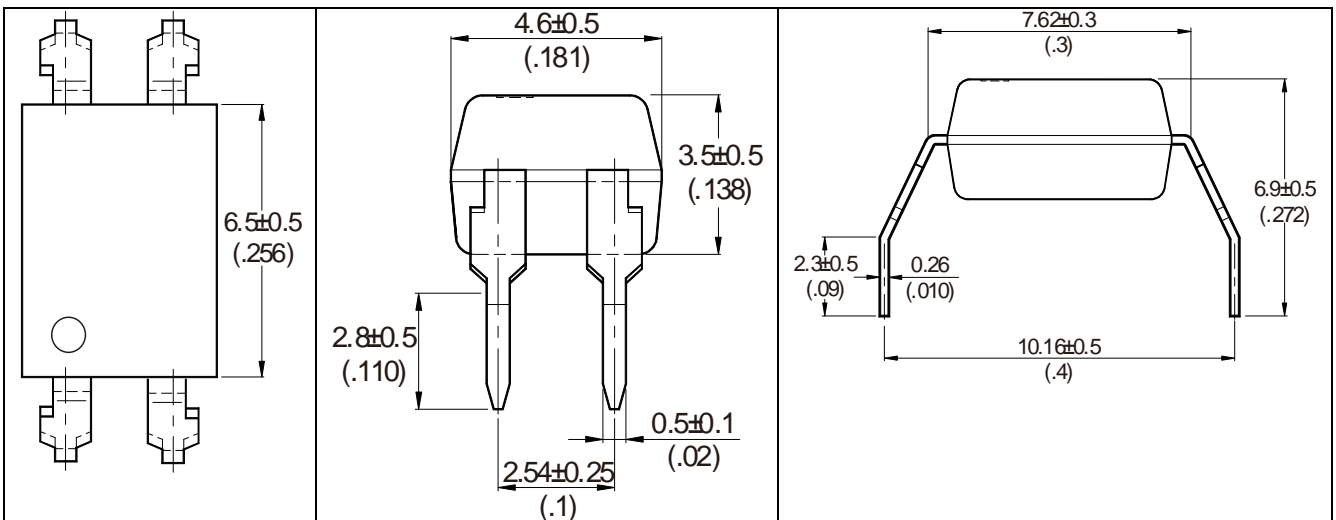

4-pin DIP (M 型)

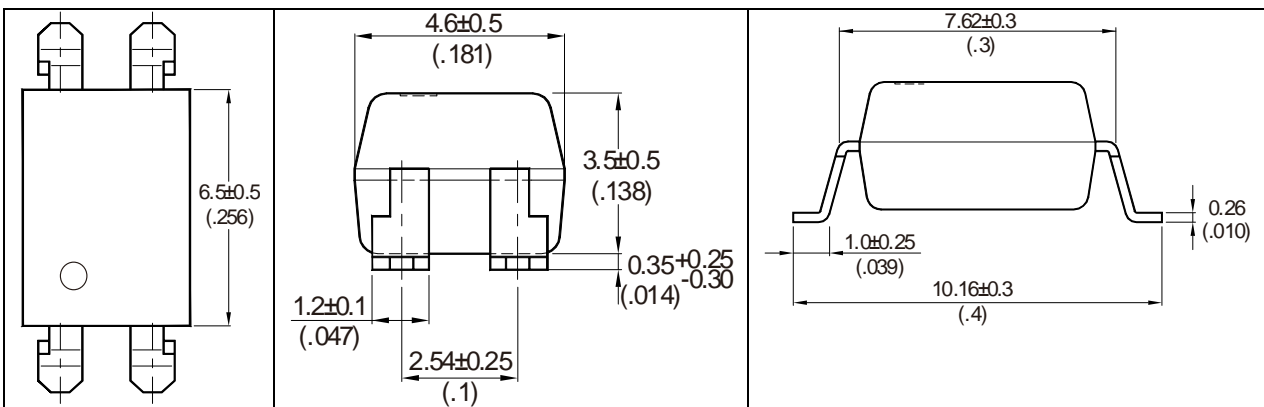

4-pin SMD

PC817X

四脚光电耦合器，晶体管输出



包装

■汇总表

封装形式	包装方式	盘数量	盒数量	箱数量	静电袋	盒规格	箱(双瓦楞)规格	备注
SMD-4	卷盘 ($\phi 330\text{mm}$ 蓝盘)	2千 只/盘	2盘/盒	10盒/箱	380*380mm	340*60*340mm	620*360*365mm	首尾端空至少 200mm
DIP-4	管装 (500*12*11mm)	100 只/管	50管/盒	10盒/箱	不适用	525*128*56mm	535*275*300mm	每管使用蓝白胶塞， 方向须一致
DIP-4 (M)	管装 (500*13*11mm)	100 只/管	50管/盒	10盒/箱	不适用	525*136*58mm	535*295*310mm	

■DIP-4 条管包装

- 1) 每箱数量：50000 只。
- 2) 内包装：
 - i. 每条管 100 只，采用防静电条管，条管上有商标、防静电标志。
 - ii. 每盒 50 条管。
- 3) 示意图：

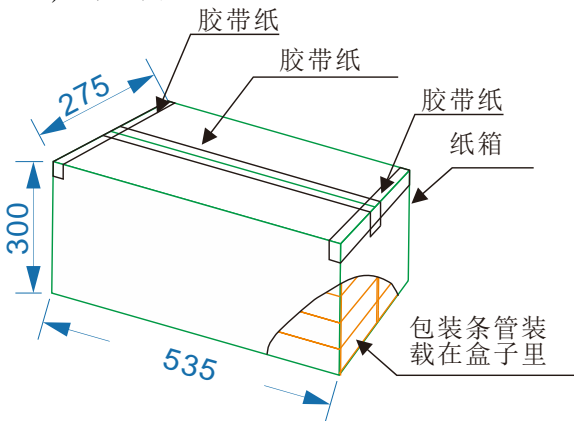

■SMD-4 编带包装

- 1) 每卷数量：2000 只。每箱数量：40000 只。
- 2) 内包装：每卷盘 2000 只。

- 3) 示意图：

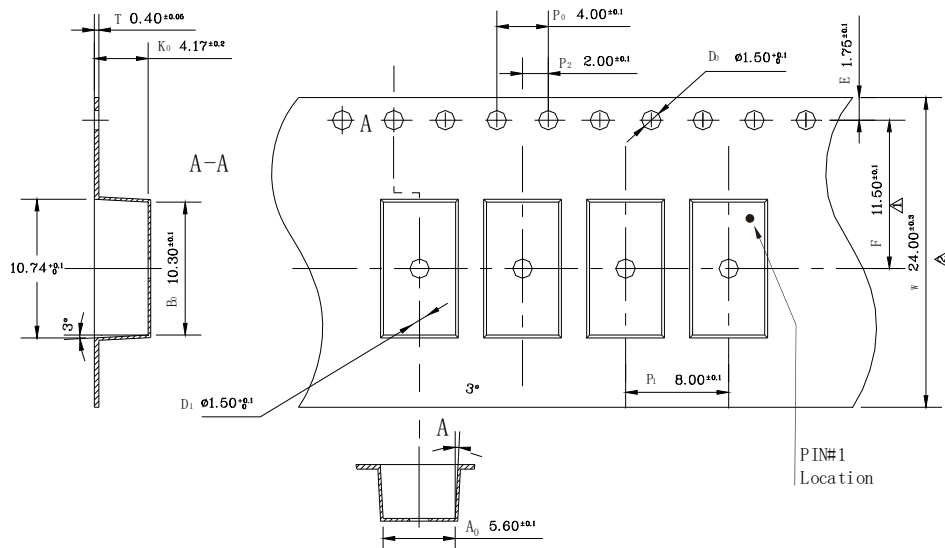

PC817X

四脚光电耦合器，晶体管输出

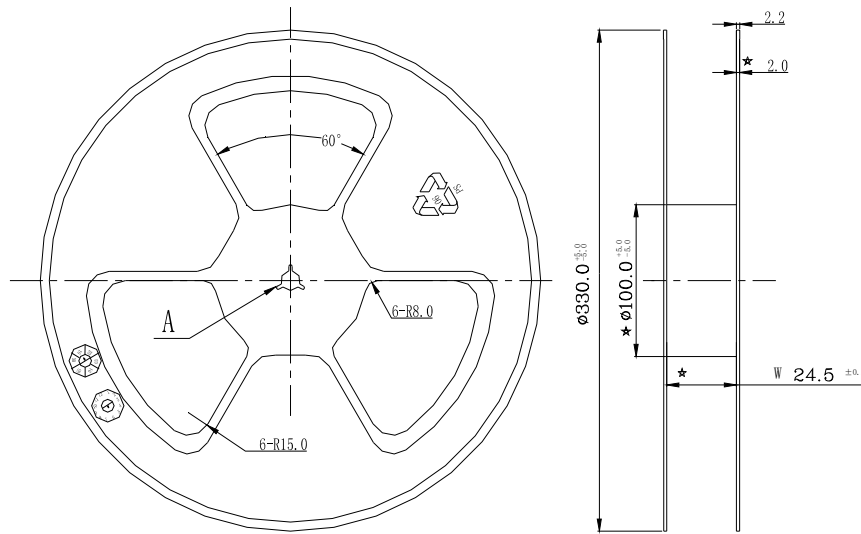

- The information described herein is subject to change without notice.
- Nanjing Micro One Electronics Inc is not responsible for any problems caused by circuits or diagrams described herein whose related industrial properties, patents, or other rights belong to third parties. The application circuit examples explain typical applications of the products, and do not guarantee the success of any specific mass-production design.
- Use of the information described herein for other purposes and/or reproduction or copying without the express permission of Nanjing Micro One Electronics Inc is strictly prohibited.
- The products described herein cannot be used as part of any device or equipment affecting the human body, such as exercise equipment, medical equipment, security systems, gas equipment, or any apparatus installed in airplanes and other vehicles, without prior written permission of Nanjing Micro One Electronics Inc.
- Although Nanjing Micro One Electronics Inc exerts the greatest possible effort to ensure high quality and reliability, the failure or malfunction of semiconductor products may occur. The user of these products should therefore give thorough consideration to safety design, including redundancy, fire-prevention measures, and malfunction prevention, to prevent any accidents, fires, or community damage that may ensue.