

产品承认书

SPECIFICATION FOR APPROVED

版本: REV.A0

客户 : **2376**
Customer : _____
客户料号 : _____
Customer P/N : _____
品名 : **SMD POWER INDUCTOR**
Description : _____
产品型号 : **CKCS4010-10 μ H/M**
CENKER P/N : _____
图纸编号 : **SP-CK112-00052370**
Drawing No. : _____
产品编号 : _____
Product code. : _____

出图 DRAWING		
制表 Prepared By	审核 Checked By	批准 Approved By
陈端贤	邓舵	万芳中
DATE: 2019-7-31		

承认 CUSTOMER APPROVAL
DATE:



深圳市岑科实业有限公司

SHENZHEN CENKER ENTERPRISE LTD.

地址:深圳市龙华区清泉路金博龙工业园C栋

Address: Building No.C Jinbolong Industrial
Estate, Qingquan Road, Longhua District, Shenzhen
P.R.China

TEL:0755-89808755 FAX:0755-27525256

SPECIFICATION FOR APPROVAL

RoHS COMPLIANT

CUSTOMER	2376	CUSTOMER No.		PAGE
CENKER P/N	CKCS4010-10μH/M	DRAWING No.	SP-CK112-00052370	1/7
ISSUE DATE	2019-7-31	VERSION	A0	

1、 DIMENSION (mm):

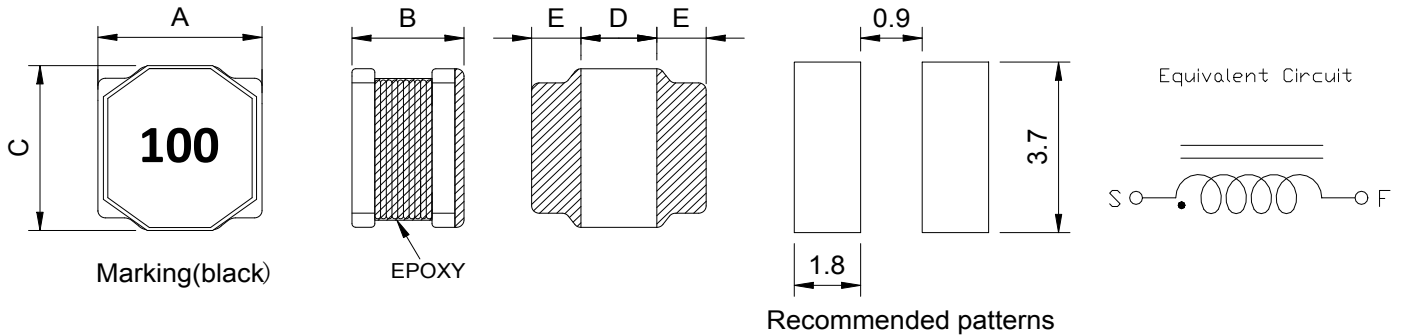

A	B	C	D	E
4.0±0.2	1.1 Max	4.0±0.2	1.4±0.3	1.3±0.3

Description of part name :

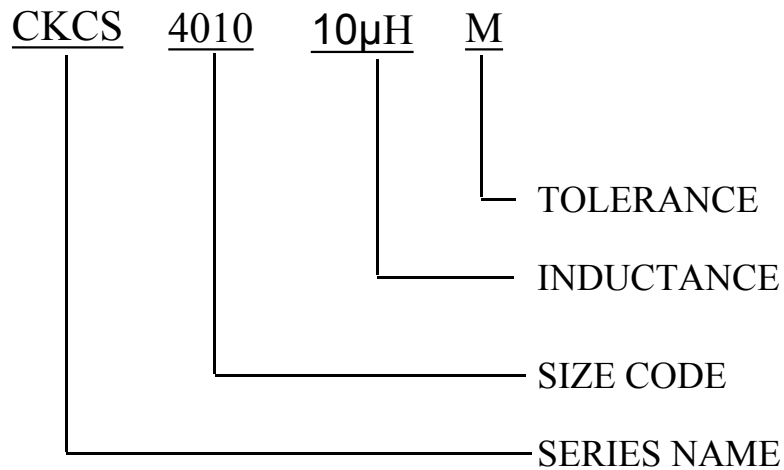

2、 TEMPERATURE RATING:

Operating Temperature : -25°C ~ +125°C ; Storage Temperature : -25°C ~ +125°C

 <p>深圳市岑科实业有限公司 SHEN ZHEN CENKER ENTERPRISE LTD. TEL:0755-89808755 FAX:0755-27525256</p>	PREPARED	CHECKED	APPROVED
	陈端贤	邓舵	万芳中

SPECIFICATION FOR APPROVAL

RoHS COMPLIANT

CUSTOMER	2376	CUSTOMER No.		PAGE
CENKER P/N	CKCS4010-10 μ H/M	DRAWING No.	SP-CK112-00052370	2/7
ISSUE DATE	2019-7-31	VERSION	A0	

3、ELECTRICAL REQUIREMENTS:

ITEM	SPEC.	TOLERANCE	TEST FREQUENCY	TEST EQUIPMENT
INDUCTANCE	10 μ H	\pm 20%	100KHz/1V	HP-4284A
DCR	0.36 Ω	Max	at 25 $^{\circ}$ C	Keysight 34420A
Isat	0.62A	LOA*70% Ref.	100KHz/1V	HP-4284A+HP-42841A
Irms	0.75A	Max	Δ T \leq 40 $^{\circ}$ C	HP-4284A+HP-42841A

Isat: DC current at which the inductance drops approximate 30% from its value without current;

Irms: DC current that causes the temperature rise (Δ T =40 $^{\circ}$ C) from 25 $^{\circ}$ C ambient.

4、MATERIAL LIST:

No.	Material	Specification	Supplier	Temp. Class
1	Core	Ferrite Core	LB	
2	Wire	Polyurethane Enamelled Copper Wire	YLSL	180 $^{\circ}$ C
3	Solder	Sn99.3-Cu0.7	CS	
4	Epoxy	Magnetic Glue	CK	



深圳市岑科实业有限公司
SHEN ZHEN CENKER ENTERPRISE LTD.
TEL:0755-89808755 FAX:0755-27525256

PREPARED	CHECKED	APPROVED
陈端贤	邓舵	万芳中

SPECIFICATION FOR APPROVAL

RoHS COMPLIANT

CUSTOMER	2376	LOT No.			
CUSTOMER No.		QUANTITY	10PCS	DATE	2019-7-31
DRAWING No.	SP-CK112-00052370	DIMENSION(UNIT: mm)			
CENKER P/N	CKCS4010-10μH/M				
DESCRIPTION	SMD POWER INDUCTOR				
TEST FREQ	100KHz/1V				
TEMPERATURE	25 °C				

5、 TESTING DATA:

ELECTRONICAL TEST DATA				OREALL DIMENSTON (UNIT: mm)									Marker
	L	L(uH) 0.62A	DCR	A	B	C	D	E					
SPE	10μH	L0A*70	0.36Ω	4.0±0.2	1.1 Max	4.0±0.2	1.4±0.3	1.3±0.3					100
C	±20%	% Ref.	Max										
1	10.57	8.72	0.30	4.09	0.99	4.04	1.35	1.37					
2	11.09	9.14	0.31	4.04	0.98	4.02	1.31	1.37					
3	11.03	9.13	0.30	4.09	1.01	4.05	1.32	1.35					
4	11.23	9.30	0.31	4.07	1.00	4.04	1.35	1.36					
5	11.28	9.31	0.31	4.07	0.99	4.02	1.33	1.35					
6	10.97	9.10	0.30	4.06	1.00	4.04	1.35	1.37					
7	11.03	9.10	0.30	4.06	1.01	4.00	1.32	1.36					
8	10.93	9.03	0.31	4.03	1.00	4.01	1.30	1.40					
9	11.27	9.32	0.31	4.08	1.01	4.07	1.32	1.39					
10	10.55	8.67	0.31	4.08	1.01	4.05	1.31	1.36					
\bar{X}	11.00	9.08	0.31	4.07	1.00	4.03	1.32	1.37					
R	0.73	0.65	0.01	0.06	0.03	0.06	0.05	0.05					

TEST EQUIPMENT:

ALL JUDGE

OK NG

L CH-1062A HP-4284A
 Q HM2801A HM9481 CJ2851
 DCR Keysight 34420A
 SRF HM9460
 IDC CD1068+CD1320 HP-4284A+HP-42841A

<p>深圳市岑科实业有限公司 SHEN ZHEN CENKER ENTERPRISE LTD. TEL:0755-89808755 FAX:0755-27525256</p>	PREPARED	CHECKED	APPROVED
	陈端贤	邓舵	万芳中

CUSTOMER	2376	CUSTOMER No.		PAGE
CENKER P/N	CKCS4010-10μH/M	DRAWING No.	SP-CK112-00052370	4/7
ISSUE DATE	2019-7-31	VERSION	A0	

6、PACKAGE :

(1) Packaging -Cover Tape

The force for tearing off cover tape is 10 to 130 grams in the arrow direction.

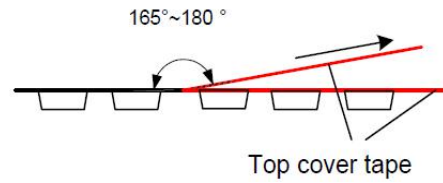
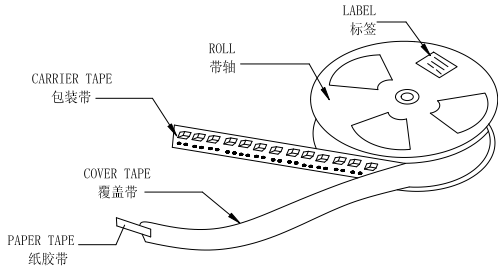

Peel-off speed: 300mm/min.

(2) Reel Dimensions (Unit:mm)

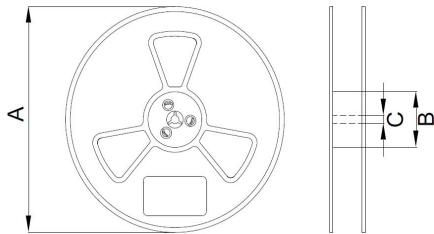

Item	Dimension
A	178±1
B	60±1
C	13±0.5

(3) Tape Dimensions(Unit:mm)

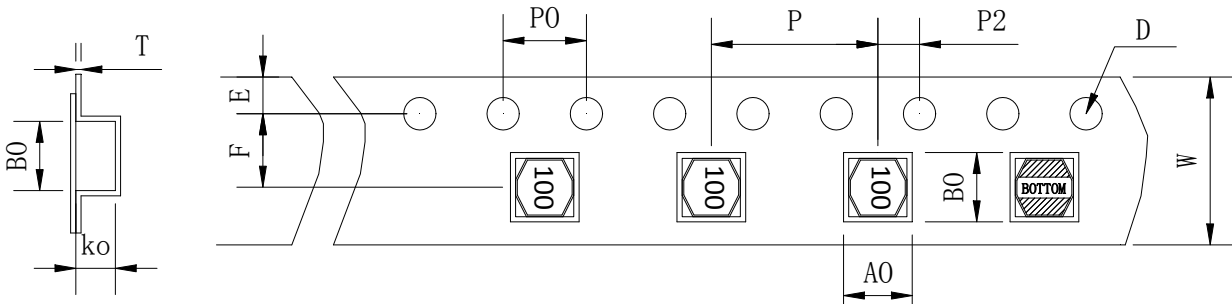

Part No.	W	A0	B0	K0	D	F	E	P	P0	P2	T
CKCS4010	12.0 ±0.3	4.3 ±0.1	4.3 ±0.1	1.3 ±0.1	1.5 ±0.1	5.5 ±0.1	1.75 ±0.1	8.0 ±0.15	4.0 ±0.1	2.0 ±0.1	0.3 ±0.05

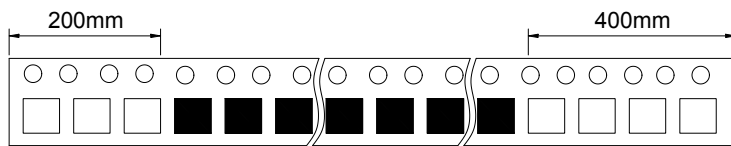

深圳市岑科实业有限公司
 SHEN ZHEN CENKER ENTERPRISE LTD.
 TEL:0755-89808755 FAX:0755-27525256

PREPARED	CHECKED	APPROVED
陈端贤	邓舵	万芳中

CUSTOMER	2376	CUSTOMER No.		PAGE
CENKER P/N	CKCS4010-10μH/M	DRAWING No.	SP-CK112-00052370	5/7
ISSUE DATE	2019-7-31	VERSION	A0	

(4) Packaging Quantity

载盘垂直放入

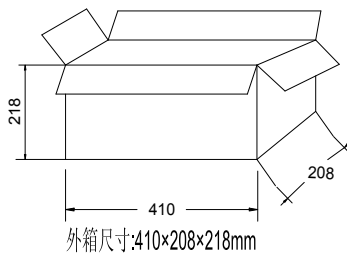
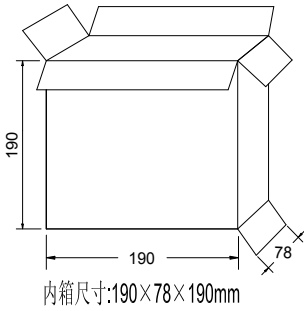
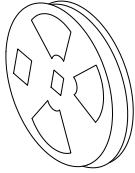

Quantity (Pcs)		
Reel	Box	Carton
1000	4000	20000
1Reel	4Reel/1Box	5Box/1Carton

7、Reflow Soldering

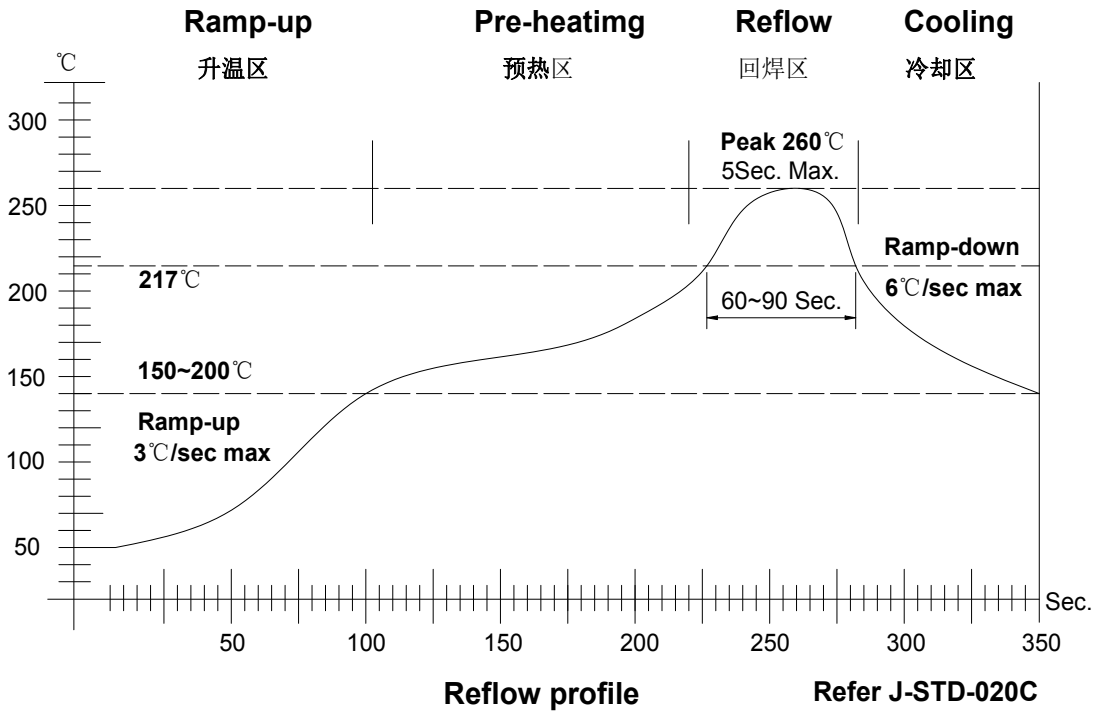

深圳市岑科实业有限公司
SHEN ZHEN CENKER ENTERPRISE LTD.
TEL:0755-89808755 FAX:0755-27525256

PREPARED	CHECKED	APPROVED
陈端贤	邓舵	万芳中

SPECIFICATION FOR APPROVAL

RoHS COMPLIANT

CUSTOMER	2376	CUSTOMER No.		PAGE
CENKER P/N	CKCS4010-10μH/M	DRAWING No.	SP-CK112-00052370	6/7
ISSUE DATE	2019-7-31	VERSION	A0	

8、Reliability Test

No.	ITEM 项目	REQUEST 要求	CONDITIONS 测试条件
1	TERMINAL STRENGTH 电极强度试验	A STATIC PULLING FORCE OF 10N IN A DIRECTION PARALLEL TO THE TERMINALS FOR 5 SECONDS 施加推拉力10牛顿，时间为5秒	NO TERMINAL BREAKAGE OR LOOSENING 未出现电极损坏或脱落现象 
2	RESISTANCE TO SOLDERING HEAT TEST 耐焊性试验	FIX THE SAMPLES ON A 1.6mm THICKNESS PCB, THEN DIP THE SAMPLE LEADS INTO A SOLDERING BATH OF 260±5°C UP TO THE PCB FOR 5±1 SECONDS. 将产品固定在1.6mm的PCB板上，放入锡炉中，温度为260±5°C，时间为5±1s.	NO MECHANICAL BREAKAGE. DEVIATION RELATIVE TO INITIAL VALUE: L: WITHIN ±10.0% 外观无损坏 电感值在 ±10.0%内
3	SOLDER ABILITY TEST 可焊性试验	IMMERSE THE TERMINAL IN FLUX FOR 5 SECONDS. THEN DIP THE TERMINAL INTO A SOLDERING BATH OF 245±5°C FOR 2±0.5 SECONDS. 端子浸入助焊剂5s，然后将端子放入锡炉中，温度为245±5°C，时间为2±0.5s	OVER 90% OF THE SURFACE BEING IMMERSSED SHALL BE COVERED WITH NEW SOLDER UNIFORMITY. 90%面积有新锡附着，焊锡表面光亮
4	HUMIDITY TEST 湿度试验	试验温度 TEMPERATURE :40±2°C 试验湿度 HUMIDITY :90%~95%RH 持续时间 DURATION:96±4 Hours	DEVIATION RELATIVE TO INITIAL VALUE: 电感的变化范围 电感值在 ±10.0%内 L: WITHIN ±10.0%
5	HIGH TEMPERATURE TEST 高温试验	试验温度 TEMPERATURE: 125 ± 2°C 试验时间 TIME: 96 ± 4 Hours 常温条件 ROOM CONDITION: 1~2 hours	DEVIATION RELATIVE TO INITIAL VALUE: 电感值在 ±10.0%内 L: WITHIN ±10.0%
6	LOW TEMPERATURE TEST 低温试验	试验温度 TEMPERATURE: -25±2°C 试验时间 TIME: 96±4 Hours 常温条件 ROOM CONDITION: 1~2 hours	DEVIATION RELATIVE TO INITIAL VALUE: 电感的变化范围 电感值在 ±10.0%内 L: WITHIN ±10.0%
7	THERMAL SHOCK TEST 冷热冲击试验	FIRST -25±5°C FOR 30±2 MINUTES, LAST 125°C 30±2 MINUTES AS 1 CYCLE. TOTAL 10 CYCLES. 首先从-25±5°C作用30±2分钟，然后温度冲击到125°C作用30±2分钟，作为一个循环，共做10个循环。	DEVIATION RELATIVE TO INITIAL VALUE: 电感的变化范围 电感值在 ±10.0%内 L: WITHIN ±10.0%
8	VIBRATION TEST 振动试验	APPLY FREQUENCY 10~55Hz 1.55mm AMPLITUDE IN EACH OF PERPENDICULAR DIRECTION FOR 2 HOURS.(TOTAL 6H) 用10~55Hz振动频率1.55mm振幅沿X,Y,Z各方向振动2小时,共6小时.	DEVIATION RELATIVE TO INITIAL VALUE: 电感的变化范围 电感值在 ±10.0%内 L: WITHIN ±10.0%



深圳市岑科实业有限公司
SHEN ZHEN CENKER ENTERPRISE LTD.
TEL:0755-89808755 FAX:0755-27525256

PREPARED	CHECKED	APPROVED
陈端贤	邓舵	万芳中

SPECIFICATION FOR APPROVAL

RoHS COMPLIANT

CUSTOMER	2376	CUSTOMER No.		PAGE
CENKER P/N	CKCS4010-10 μ H/M	DRAWING No.	SP-CK112-00052370	7/7
ISSUE DATE	2019-7-31	VERSION	A0	

9、INDUCTANCE (μ H) VS DC BIAS (A) CURVE

DC BIAS (A)	Inductance (μ H)	Δ L/L (%)				
0 A	11.09					
0.10 A	10.91	98.38%				
0.20 A	10.78	97.20%				
0.30 A	10.55	95.13%				
0.40 A	10.25	92.43%				
0.50 A	9.86	88.91%				
0.60 A	9.28	83.68%				
0.70 A	8.41	75.83%				
0.80 A	6.77	61.05%				
0.90 A	4.51	40.67%				

TESTING CONDITION: 100kHz/1V

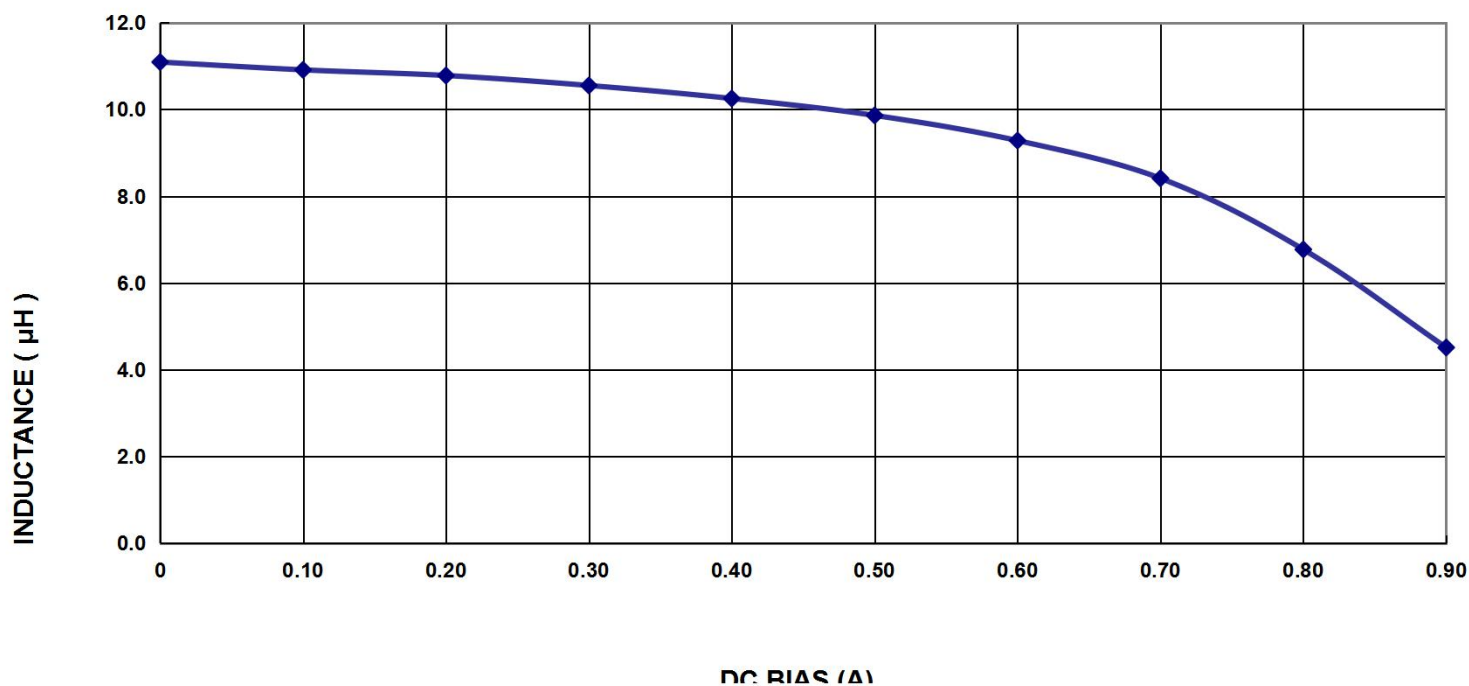

深圳市岑科实业有限公司
 SHEN ZHEN CENKER ENTERPRISE LTD.
 TEL:0755-89808755 FAX:0755-27525256

PREPARED

陈端贤

CHECKED

邓舵

APPROVED

万芳中