

APPROVAL SHEET



WLCM0603

WLCM1005

Multi-Layer Ceramic High Frequency Inductors



*Contents in this sheet are subject to change without prior notice.

FEATURES

1. Ceramic structure provides high reliability · high productivity.
2. Excellence Q and SRF characteristics for RF application.
3. Wide range inductance and various tolerance options.
4. RoHS compliance.

APPLICATIONS

1. Communication system front-end circuit: GSM/3G/LTE, Wi-Fi, GPS.
2. Cabel/Terrestrial/BS Tuner, Bluetooth, Wireless Audio, Remote control.
3. M2M: ZigBee, Proprietary wilreless.
4. EMI solusion in high frequency circuits.

SHAPE and DIMENSION

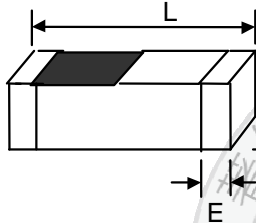

Unit: mm

WLCM Series	L	W	T	E (Min/Max)	Packing Quantity (pcs/reel)
					Paper Tape
WLCM0603 (EIA 0201)	0.60±0.03	0.30±0.03	0.30±0.03	0.10~0.20	15,000
WLCM1005 (EIA 0402)	1.00±0.10	0.50±0.10	0.50±0.10	0.10~0.30	10,000

Ordering Information

WL	CM	0603	Z0	S	1N2	T	B
Product Code WL: Inductor	Series Ceramic multilayer inductor.	Dimensions 1005:EIA 0402 0603:EIA 0201	Series extension Z0:STD	Tolerance B: ± 0.1nH C: ± 0.2nH S: ± 0.3nH G: ± 2% H: ± 3% J: ± 5%	Value 1N2 =1.2nH 12N=12nH R10=100nH =0.10uH	Packing Code T=7" Reeled (Paper tape)	B:STD

Electrical Characteristics

- WLCM0603 series (EIA 0201)

Operating Temperature range: -55°C to 125°C

Walsin Part Number	L(nH)	Tolerance	Q Min	Typical Q @ Frequency (MHz)	SRF (MHz)	RDC (Ω)	Rated Current (mA) Max.
					Min.	Max.	
WLCM0603Z0□0N3TB	0.3	B, C, S	4	100	10,000	0.07	850
WLCM0603Z0□0N4TB	0.4	B, C, S	4	100	10,000	0.07	850
WLCM0603Z0□0N5TB	0.5	B, C, S	4	100	10,000	0.08	800
WLCM0603Z0□0N6TB	0.6	B, C, S	4	100	10,000	0.08	800
WLCM0603Z0□0N7TB	0.7	B, C, S	4	100	10,000	0.09	750
WLCM0603Z0□0N8TB	0.8	B, C, S	4	100	10,000	0.10	750
WLCM0603Z0□0N9TB	0.9	B, C, S	4	100	10,000	0.10	750
WLCM0603Z0□1N0TB	1.0	B, C, S	4	100	10,000	0.14	600
WLCM0603Z0□1N1TB	1.1	B, C, S	4	100	10,000	0.14	600
WLCM0603Z0□1N2TB	1.2	B, C, S	4	100	10,000	0.14	600
WLCM0603Z0□1N3TB	1.3	B, C, S	4	100	10,000	0.14	600
WLCM0603Z0□1N4TB	1.4	B, C, S	4	100	10,000	0.18	550
WLCM0603Z0□1N5TB	1.5	B, C, S	4	100	10,000	0.18	550
WLCM0603Z0□1N6TB	1.6	B, C, S	4	100	10,000	0.18	500
WLCM0603Z0□1N7TB	1.7	B, C, S	4	100	10,000	0.19	500
WLCM0603Z0□1N8TB	1.8	B, C, S	4	100	10,000	0.19	500
WLCM0603Z0□1N9TB	1.9	B, C, S	4	100	10,000	0.20	450
WLCM0603Z0□2N0TB	2.0	B, C, S	4	100	10,000	0.20	450
WLCM0603Z0□2N1TB	2.1	B, C, S	4	100	10,000	0.20	450
WLCM0603Z0□2N2TB	2.2	B, C, S	4	100	10,000	0.22	450
WLCM0603Z0□2N3TB	2.3	B, C, S	4	100	10,000	0.22	450
WLCM0603Z0□2N4TB	2.4	B, C, S	4	100	10,000	0.24	450
WLCM0603Z0□2N5TB	2.5	B, C, S	4	100	10,000	0.24	450
WLCM0603Z0□2N6TB	2.6	B, C, S	4	100	10,000	0.25	450
WLCM0603Z0□2N7TB	2.7	B, C, S	5	100	10,000	0.25	450
WLCM0603Z0□2N9TB	2.9	B, C, S	5	100	9,500	0.28	450
WLCM0603Z0□3N0TB	3.0	B, C, S	5	100	9,500	0.28	450
WLCM0603Z0□3N1TB	3.1	B, C, S	5	100	9,500	0.28	450
WLCM0603Z0□3N2TB	3.2	B, C, S	5	100	9,500	0.30	450
WLCM0603Z0□3N3TB	3.3	B, C, S	5	100	9,500	0.30	450
WLCM0603Z0□3N4TB	3.4	B, C, S	5	100	8,000	0.30	400
WLCM0603Z0□3N5TB	3.5	B, C, S	5	100	8,000	0.30	400
WLCM0603Z0□3N6TB	3.6	B, C, S	5	100	8,000	0.30	400
WLCM0603Z0□3N7TB	3.7	B, C, S	5	100	8,000	0.30	400
WLCM0603Z0□3N8TB	3.8	B, C, S	5	100	6,500	0.30	400
WLCM0603Z0□3N9TB	3.9	B, C, S	5	100	6,500	0.30	400
WLCM0603Z0□4N3TB	4.3	B, C, S	5	100	6,500	0.40	350
WLCM0603Z0□4N7TB	4.7	B, C, S	5	100	6,500	0.40	350
WLCM0603Z0□5N1TB	5.1	B, C, S	5	100	6,500	0.40	350

Walsin Part Number	L(nH)	Tolerance	Q Min	Typical Q @ Frequency (MHz)	SRF (MHz)	RDC (Ω)	Rated Current (mA) Max.
					Min.	Max.	
WLCM0603Z0□5N6TB	5.6	B, C, S	5	100	6,000	0.40	350
WLCM0603Z0□6N2TB	6.2	B, C, S	5	100	6,000	0.44	300
WLCM0603Z0□6N8TB	6.8	H, J	5	100	5,400	0.50	300
WLCM0603Z0□7N5TB	7.5	H, J	5	100	4,800	0.53	300
WLCM0603Z0□8N2TB	8.2	H, J	5	100	4,800	0.55	250
WLCM0603Z0□9N1TB	9.1	H, J	5	100	4,500	0.62	250
WLCM0603Z0□10NTB	10	H, J	5	100	4,500	0.65	250
WLCM0603Z0□12NTB	12	H, J	5	100	3,700	0.70	250
WLCM0603Z0□15NTB	15	H, J	5	100	2,200	0.80	250
WLCM0603Z0□18NTB	18	H, J	5	100	2,200	0.90	200
WLCM0603Z0□22NTB	22	H, J	5	100	2,000	1.20	150
WLCM0603Z0□27NTB	27	H, J	4	100	1,800	1.80	140
WLCM0603Z0□33NTB	33	J	4	100	1,700	2.10	120
WLCM0603Z0□39NTB	39	J	4	100	1,500	2.40	120
WLCM0603Z0□47NTB	47	J	4	100	1,300	2.80	100
WLCM0603Z0□56NTB	56	J	4	100	1,100	3.00	80
WLCM0603Z0□68NTB	68	J	4	100	1,100	2.66	80
WLCM0603Z0□82NTB	82	J	4	100	1,000	3.37	70
WLCM0603Z0□R10TB	100	J	4	100	900	3.74	60

Typical Electrical Characteristic

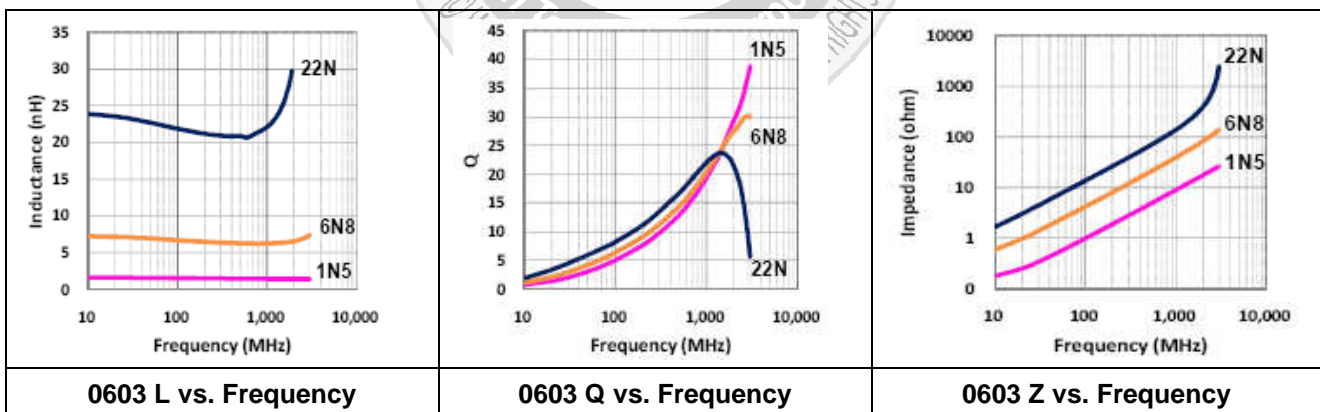

● WLCM1005 series (EIA 0402)

Operating Temperature range: -55°C to 125°C

Walsin Part Number	L(nH)	Tolerance	Q Min	Typical Q @ Frequency (MHz)	SRF (MHz)	RDC (Ω)	Rated Current (mA) Max
					Min.	Max.	
WLCM1005Z0□0N3TB	0.3	B, C, S	8	100	10,000	0.08	380
WLCM1005Z0□0N4TB	0.4	B, C, S	8	100	10,000	0.08	380
WLCM1005Z0□0N5TB	0.5	B, C, S	8	100	10,000	0.08	380
WLCM1005Z0□0N6TB	0.6	B, C, S	8	100	10,000	0.08	380
WLCM1005Z0□0N7TB	0.7	B, C, S	8	100	10,000	0.08	380
WLCM1005Z0□0N8TB	0.8	B, C, S	8	100	10,000	0.08	380
WLCM1005Z0□1N0TB	1.0	B, C, S	8	100	10,000	0.08	380
WLCM1005Z0□1N1TB	1.1	B, C, S	8	100	10,000	0.08	380
WLCM1005Z0□1N2TB	1.2	B, C, S	8	100	10,000	0.09	380
WLCM1005Z0□1N3TB	1.3	B, C, S	8	100	10,000	0.09	380
WLCM1005Z0□1N5TB	1.5	B, C, S	8	100	10,000	0.10	380
WLCM1005Z0□1N6TB	1.6	B, C, S	8	100	10,000	0.10	380
WLCM1005Z0□1N8TB	1.8	B, C, S	8	100	10,000	0.12	380
WLCM1005Z0□2N0TB	2.0	B, C, S	8	100	10,000	0.12	380
WLCM1005Z0□2N2TB	2.2	B, C, S	8	100	10,000	0.13	380
WLCM1005Z0□2N4TB	2.4	B, C, S	8	100	10,000	0.13	380
WLCM1005Z0□2N7TB	2.7	B, C, S	8	100	6,000	0.16	380
WLCM1005Z0□3N0TB	3.0	B, C, S	8	100	6,000	0.16	380
WLCM1005Z0□3N3TB	3.3	B, C, S	8	100	6,000	0.16	300
WLCM1005Z0□3N6TB	3.6	B, C, S	8	100	6,000	0.20	300
WLCM1005Z0□3N9TB	3.9	B, C, S	8	100	6,000	0.20	300
WLCM1005Z0□4N3TB	4.3	B, C, S	8	100	6,000	0.20	300
WLCM1005Z0□4N7TB	4.7	B, C, S	8	100	6,000	0.20	300
WLCM1005Z0□5N1TB	5.1	B, C, S	8	100	5,300	0.23	300
WLCM1005Z0□5N6TB	5.6	B, C, S	8	100	4,500	0.23	300
WLCM1005Z0□6N2TB	6.2	B, C, S	8	100	4,500	0.25	300
WLCM1005Z0□6N8TB	6.8	G, H, J	8	100	4,500	0.25	300
WLCM1005Z0□7N5TB	7.5	G, H, J	8	100	4,200	0.28	300
WLCM1005Z0□8N2TB	8.2	G, H, J	8	100	3,700	0.28	300
WLCM1005Z0□9N1TB	9.1	G, H, J	8	100	3,400	0.30	300
WLCM1005Z0□10NTB	10	G, H, J	8	100	3,400	0.30	300
WLCM1005Z0□12NTB	12	G, H, J	8	100	3,000	0.45	300
WLCM1005Z0□13NTB	13	G, H, J	8	100	3,000	0.50	300
WLCM1005Z0□15NTB	15	G, H, J	8	100	2,500	0.55	300
WLCM1005Z0□18NTB	18	G, H, J	8	100	2,200	0.65	300
WLCM1005Z0□22NTB	22	G, H, J	8	100	1,900	0.70	300
WLCM1005Z0□24NTB	24	G, H, J	8	100	1,700	0.70	300

Walsin Part Number	L(nH)	Tolerance	Q Min	Typical Q @ Frequency (MHz)	SRF (MHz)		RDC (Ω)	Rated Current (mA) Max
					Min.	Max.		
WLCM1005Z0□27NTB	27	G, H, J	8	100	1,700	0.80	300	
WLCM1005Z0□33NTB	33	G, H, J	8	100	1,600	0.90	200	
WLCM1005Z0□39NTB	39	G, H, J	8	100	1,200	1.00	200	
WLCM1005Z0□47NTB	47	G, H, J	8	100	1,100	1.10	200	
WLCM1005Z0□56NTB	56	G, H, J	8	100	1,000	1.10	200	
WLCM1005Z0□68NTB	68	G, H, J	8	100	800	1.20	200	
WLCM1005Z0□82NTB	82	H, J	8	100	600	1.30	200	
WLCM1005Z0□R10TB	100	J	8	100	600	1.60	200	
WLCM1005Z0□R12TB	120	J	8	100	600	1.60	150	
WLCM1005Z0□R15TB	150	J	8	100	550	3.20	140	
WLCM1005Z0□R18TB	180	J	8 </td <td>100</td> <td>500</td> <td>3.70</td> <td>130</td>	100	500	3.70	130	
WLCM1005Z0□R22TB	220	J	8	100	450	4.20	120	
WLCM1005Z0□R27TB	270	J	8	100	400	4.80	110	

Typical Electrical Characteristic

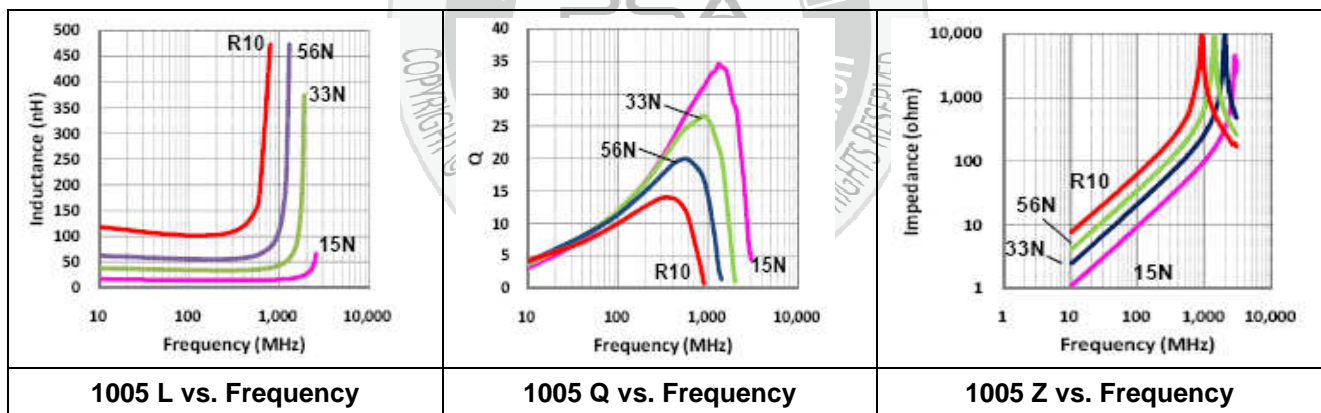

Test condition & Requirements (WLCM series)

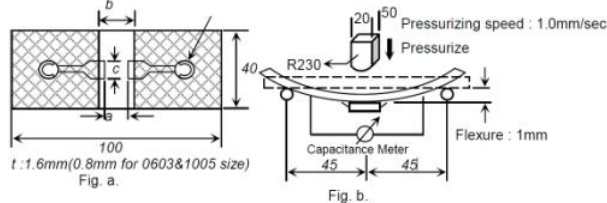
No.	Item	Test condition	Requirements
1	Appearance	Inductors shall be visually inspected for visible evidence of defect.	No harmful defect for piratical use.
2	Inductance	a. Temperature: 25+/- 3°C b. Relative Humidity: 45 to 75%RH c. Measurement Voltage: 500mV d. Measuring equipment and fixture: 0603(0201) Agilent 4287+16196C 1005(0402) Agilent 4287+16193A	Within specified tolerance
3	Q Value	a. Temperature: 25 ± 3°C b. Relative Humidity: 45 to 75%RH c. Measurement Voltage: 500mV d. Measuring equipment and fixture: 0603(0201) Agilent 4287+16196C 1005(0402) Agilent 4287+16193A	In accordance with electrical specification
4	DC Resistance	a. Temperature: 25 ± 3°C b. Relative Humidity: 45 to 75%RH c. Measuring equipment: Agilent 4338	In accordance with electrical specification
5	Dimension	Dimension shall be measured with calliper or micrometer	In accordance with dimension specification.
6	Solder-ability	Immerse a test sample into a methanol solution containing rosin and immerse into SAC305 (Sn96.5Ag3.0Cu0.5) solder of 245±5, for 3±1.	90% of the termination is to be soldered evenly and continuously.
7	Resistance to Soldering Heat	Immerse a test sample into a methanol solution containing resin, preheat it at 120 to 150°C for 1 minutes and immerse into molten solder of 270 ± 5 °C for 10 ± 1 second so that both terminal electrodes are completely submerged.	No visible damage. Inductance variation within 10% Q variation within 20%
8	Bending Strength	Solder the chip to test jig then apply a force in the direction shown in below. The soldering shall be done with the reflow method and shall be conducted with care so that the soldering is uniform and free of defects such as heat shock. 	No mechanical damage shall be observed. Rdc-value : to meet the initial Spec.

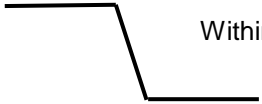
No.	Item	Test condition	Requirements
9	Thermal Shock	<p>Solder a test sample to printed circuit board, and conduct 5 cycles of test under the conditions shown as below.</p> <p>0603(0201) & 1005(0402) :</p> <p>Operating temp. range: -55~125°C</p> <p>Maximum operating temp. (30+/-3min)</p>  <p>Minimum operating temp. (30+/-3min)</p>	<p>No visible damage.</p> <p>Inductance variation within 10% Q variation within 20%</p>
10	High Humidity State Life Test	<p>Keep a test sample in an atmosphere with a temperature of 40±2°C, 90~95% RH for 500 +24/-0 hours.</p> <p>After the removal from the chamber, 2 to 3 hours of recovery under standard condition, and measurement shall be made after 24±2 hrs recovery under standard condition.</p>	<p>No visible damage.</p> <p>Inductance variation within 10% Q variation within 20%</p>
11	High Humidity Load Life Test	<p>Solder a test sample to printed circuit board then keep the test sample in an atmosphere with a temperature of 40±2, 90~95%RH for 500+24/-0 hours while supplying the rated current.</p> <p>After the removal from test chamber, 2 to 3 hours of recovery under standard condition, and measurement shall be made after 24±2 hrs of recovery under standard condition.</p>	<p>No visible damage.</p> <p>Inductance variation within 10% Q variation within 20%</p>
12	High Temperature State Life Test	<p>Keep a test sample in an atmosphere with a temperature of 85±2°C for 500±12 hours. After the removal from test chamber, 2 to 3 hours of recovery under standard condition, and measurement shall be made after 24±2 hrs of recovery under standard condition.</p>	<p>No visible damage.</p> <p>Inductance variation within 10% Q variation within 20%</p>
13	High Temperature Load	<p>Solder a test sample to printed circuit board then keep the test sample in an atmosphere with a temperature of 85±2°C for 500±12 hours while supplying the rated current.</p> <p>After the removal from test chamber, 2 to 3 hours of recovery under standard condition, and measurement shall be made after 24±2 hrs of recovery under standard condition.</p>	<p>No visible damage.</p> <p>Inductance variation within 10% Q variation within 20%</p>

Reflow soldering conditions

Pre-heating should be in such a way that the temperature difference between solder and ferrite surface is limited to 150°C max. Also cooling into solvent after soldering should be in such a way that the temperature difference is limited to 100°C max.

Insufficient pre-heating may cause cracks on the ferrite, resulting in the deterioration of product quality.

Products should be soldered within the following allowable range indicated by the slanted line. The excessive soldering conditions may cause the corrosion of the electrode, when soldering is repeated, allowable time is the accumulated time.

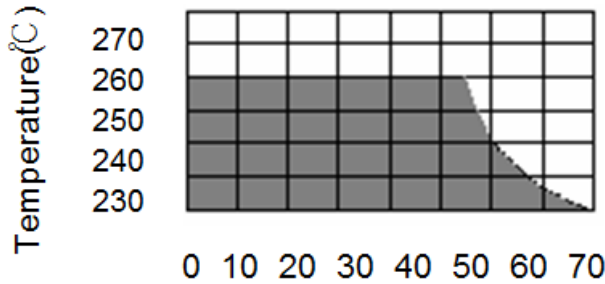

Temperature Profile

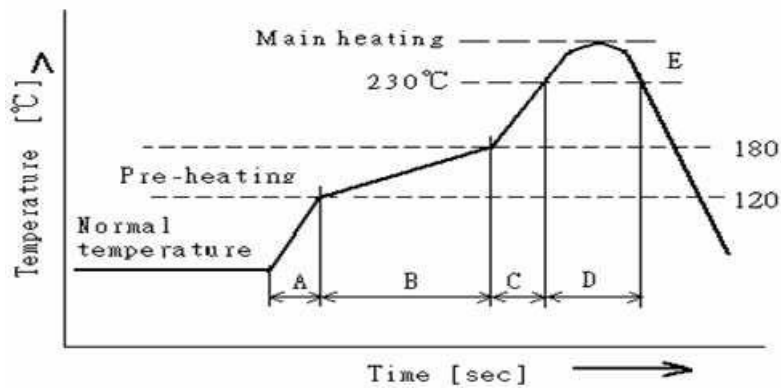

A	Slope of temp. rise	1 ~ 5	°C/sec
B	Heat time	50 ~ 150	sec
	Heat temperature	120 ~ 180	°C
C	Slope of temp. rise	1 ~ 5	°C/sec
D	Time over 230°C	90 ~ 120	sec
E	Peak temperature	255~260	°C
	Peak hold time	10 max.	sec
No. of mounting		3	Items

Reworking with soldering iron

Preheating	150°C, 1 minute
Tip temperature	280°C max.
Soldering time	3 seconds max.
Soldering iron output	30w max.
End of soldering iron	f 3mm max.

- Reworking should be limited to only one time.

Note : Do not directly touch the products with the tip of the soldering iron in order to prevent the crack on the ferrite material due to the thermal shock.

- Solder Volume

Solder shall be used not to be exceed the upper limits as shown below.

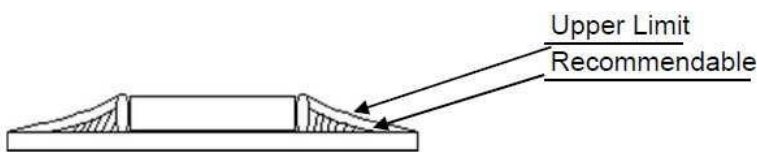

Accordingly increasing the solder volume, the mechanical stress to product is also increased. Exceeding solder volume may cause the failure of mechanical or electrical performance.



Packaging Specification

Paper Tape

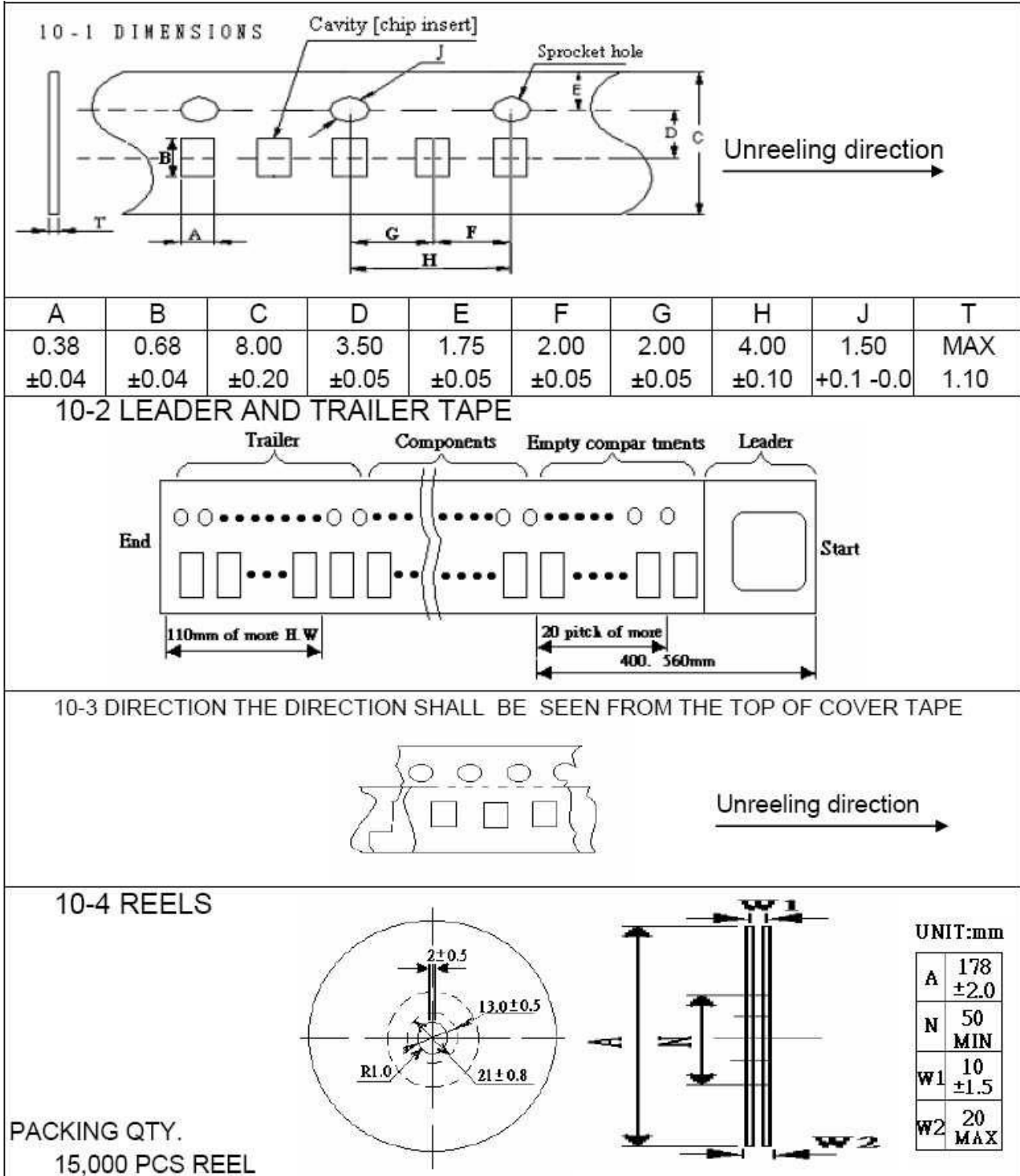

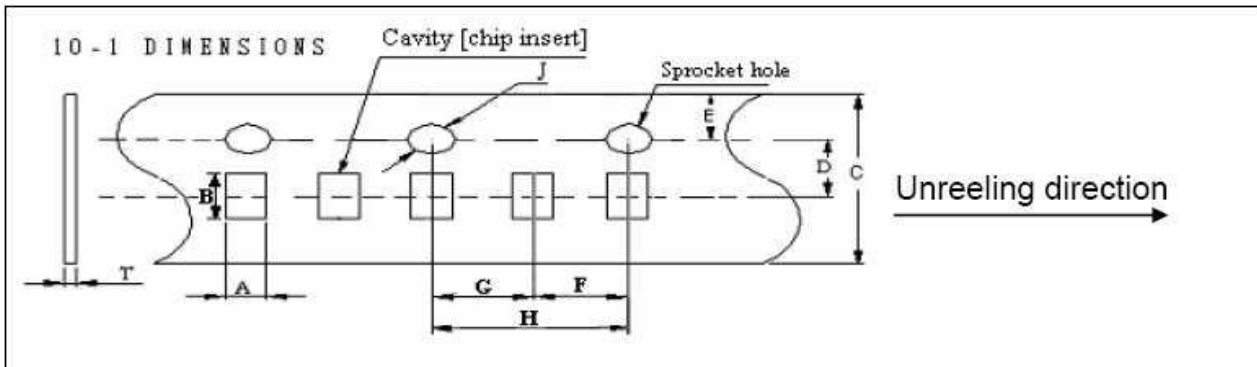

A	B	C	D	E	F	G	H	J	T
0.62	1.12	8.00	3.50	1.75	2.00	2.00	4.00	1.55	0.6
±0.05	±0.05	±0.10	±0.05	±0.10	±0.05	±0.05	±0.10	±0.05	±0.05

10-2 LEADER AND TRAILER TAPE

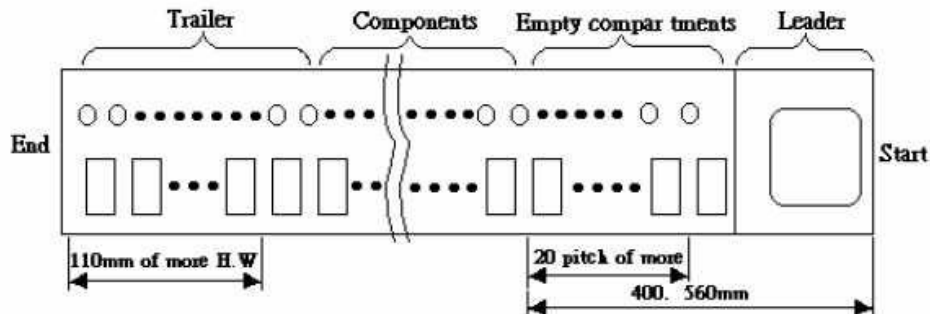

10-3 DIRECTION THE DIRECTION SHALL BE SEEN FROM THE TOP OF COVER TAPE



10-4 REELS

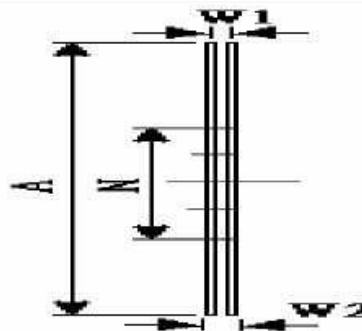
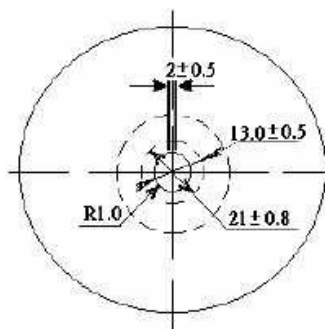

UNIT:mm

A	178 ±2.0
N	50 MIN
W1	10 ±1.5
W2	20 MAX

PACKING QTY.
10,000 PCS REEL

Quantity per reel

WLCM0603 : 15K pcs

WLCM1005 : 10K pcs