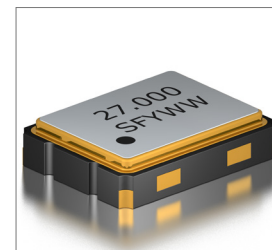
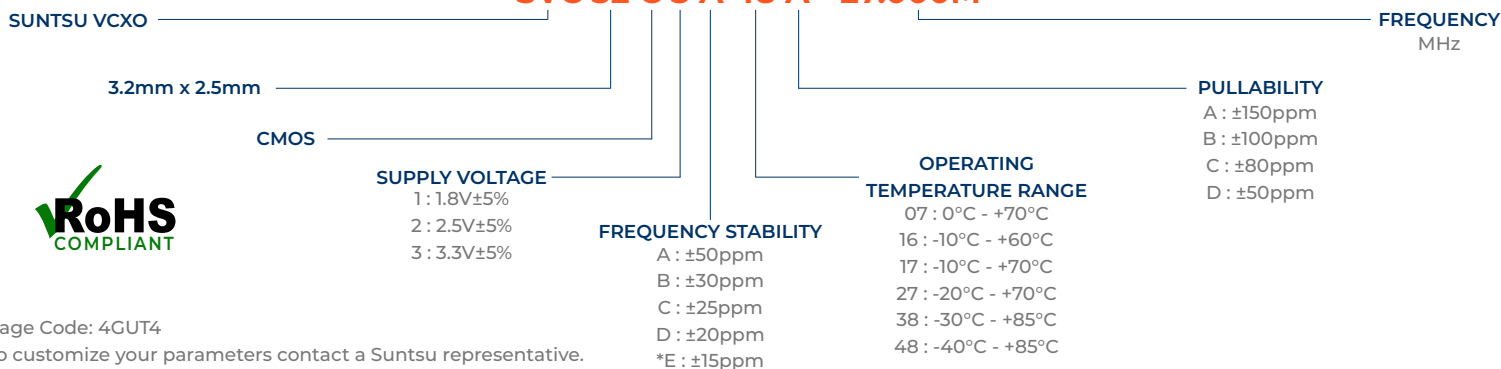

Features
• ± 20 ppm (Frequency Stability) Available
• Miniature Package
• CMOS
• Fundamental
• Tape and Reel

Applications
• Digital TV
• DVD, STB
• PCMA, XDSL
• Broadband Access
• Base Stations

Part Numbering Guide
SVC 32 C 3 A 48 A - 27.000M

Cage Code: 4GUT4

To customize your parameters contact a Suntsu representative.

* For frequency stability option E contact a Suntsu representative.

Electrical Parameters	Units	Minimum	Typical	Maximum	Remarks
Frequency Range	MHz	1		55	
Frequency Stability (Includes Initial Tolerance at 25°C, Frequency Stability over Operating Temperature, Output Load Change, Supply Voltage Change, and First Year Aging at 25°C.)	ppm	-20		+20	See part numbering guide for options.
Operating Temperature	°C	-40		+85	See part numbering guide for options.
Storage Temperature	°C	-55		+125	
Supply Voltage (V _{DD}) 1.8V Option	V	1.710	1.8	1.890	
Supply Voltage (V _{DD}) 2.5V Option	V	2.375	2.5	2.625	
Supply Voltage (V _{DD}) 3.3V Option	V	3.135	3.3	3.465	
Current (I _{DD}) 1.8V Option	mA			10	
Current (I _{DD}) 2.5V Option	mA			15	
Current (I _{DD}) 3.3V Option	mA			25	
Current Voltage (V _c) 1.8V Option	V	0.15		1.65	
Current Voltage (V _c) 2.5V Option	V	0.2		2.3	
Current Voltage (V _c) 3.3V Option	V	0.3		3.0	
Pullability	ppm	±50	±100	±150	See part numbering guide for options.
Linearity	%			10	
Output Load (CMOS)	pF			15	
Output Logic HIGH Level (V _{OH})	V	0.9*V _{DD}			
Output Logic LOW Level (V _{OL})	V			0.1*V _{DD}	
Rise (T _R) And Fall (T _F) Time	ns			5	
Symmetry (Duty Cycle)	%	45	50	55	
Start-Up Time	ms			10	
Phase Jitter (12KHz ~ 20MHz)	ps			1	

Outline Drawing & Land Pattern

All dimensions are in millimeters (mm) unless otherwise noted. Drawings are not to scale.

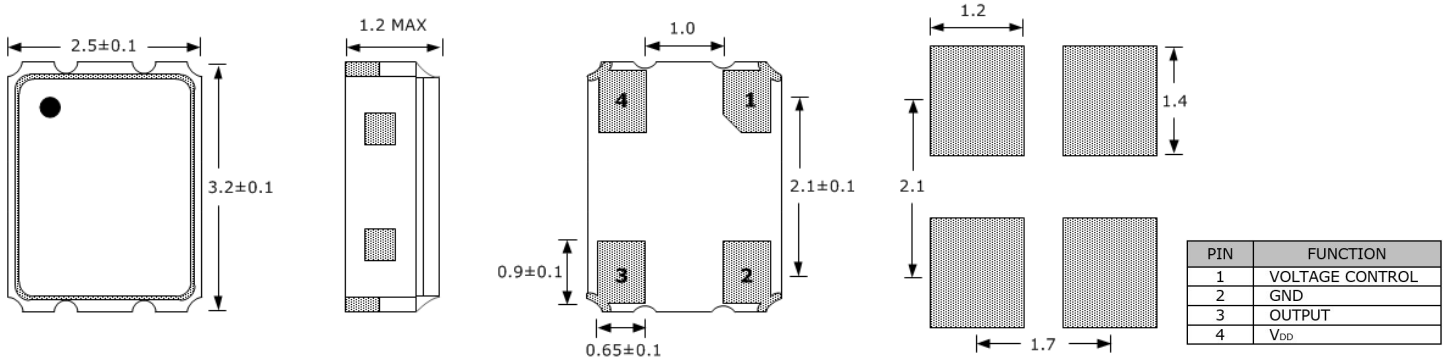

Test Circuit (CMOS)

Waveform (CMOS)

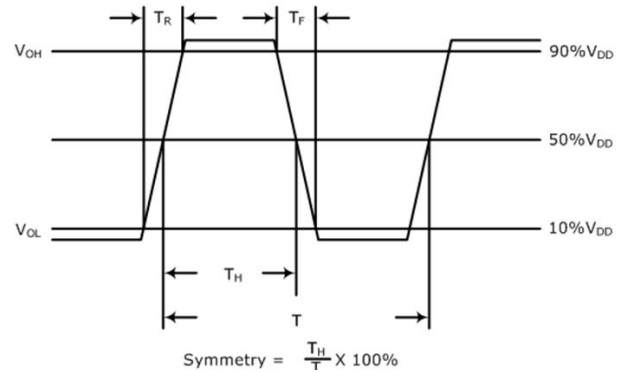
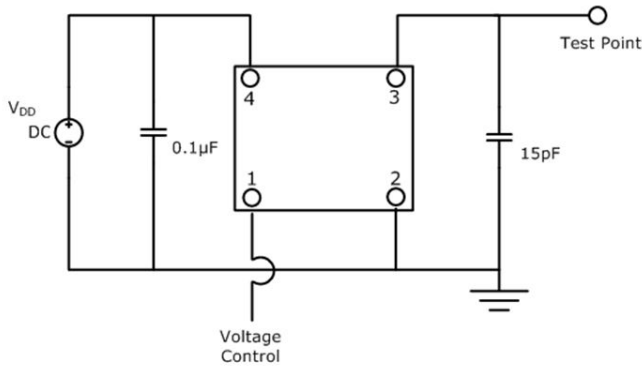

Typical Phase Noise Performance (Measured By Agilent E5052A)

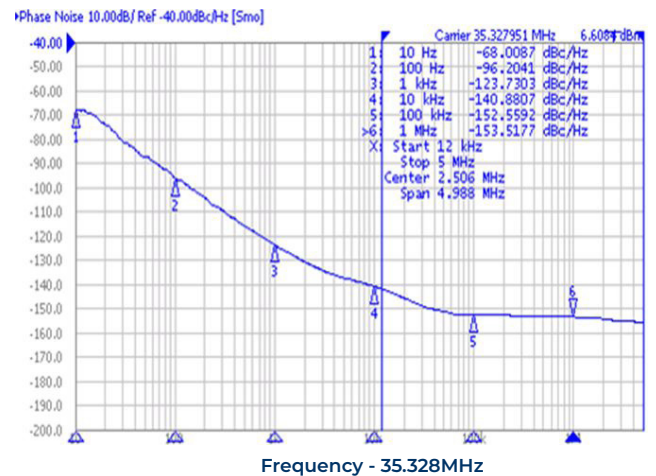
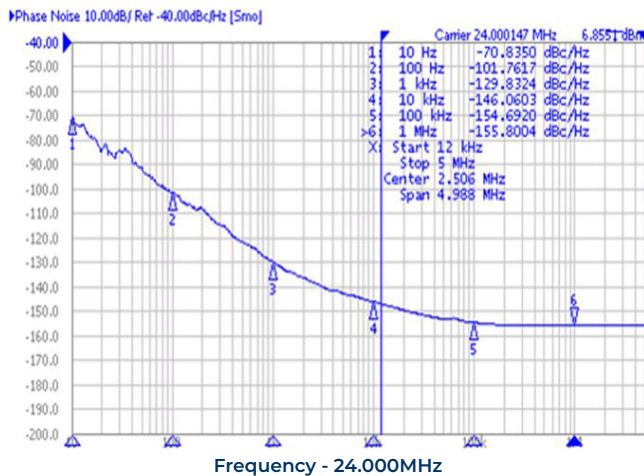

Typical Jitter Performance (Measured By Agilent E5052A)

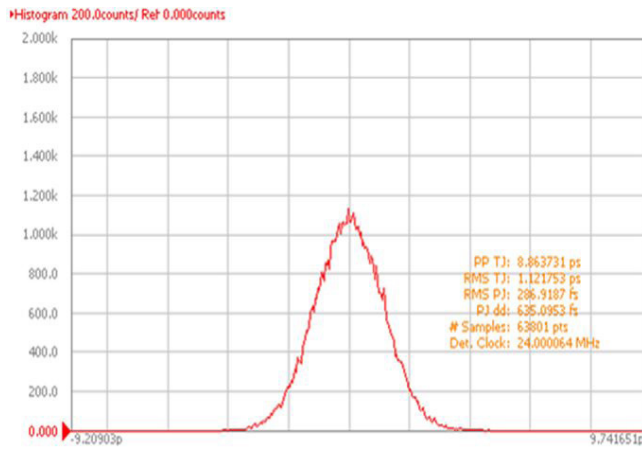

Frequency - 24.000MHz

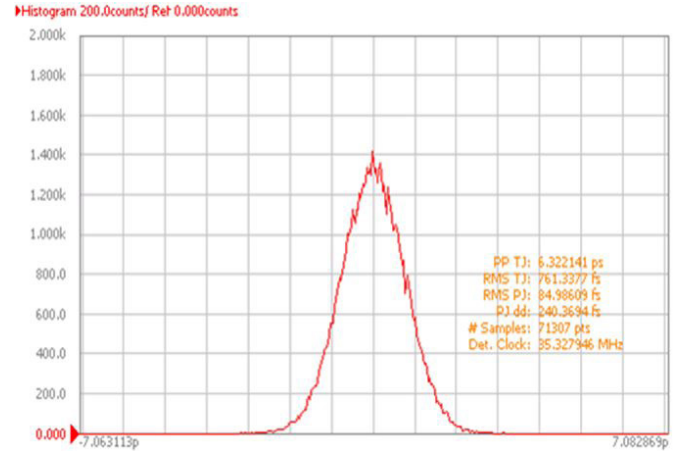

Frequency - 35.328MHz

Reflow Profile

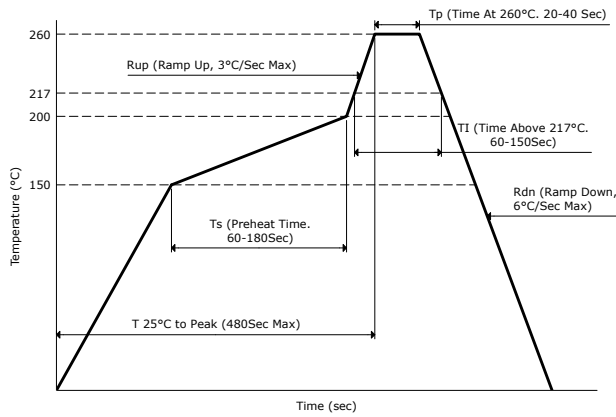

Part Marking

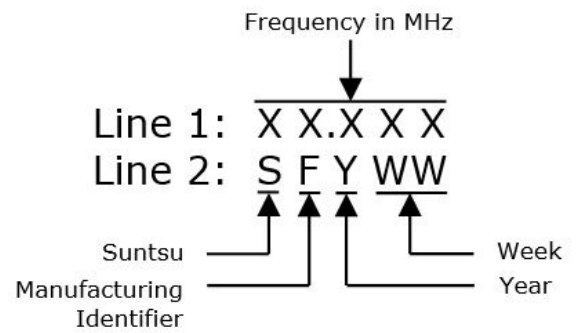

Tape And Reel Dimensions

All dimensions are in millimeters (mm) unless otherwise noted. Drawings are not to scale.

3,000pcs/Reel

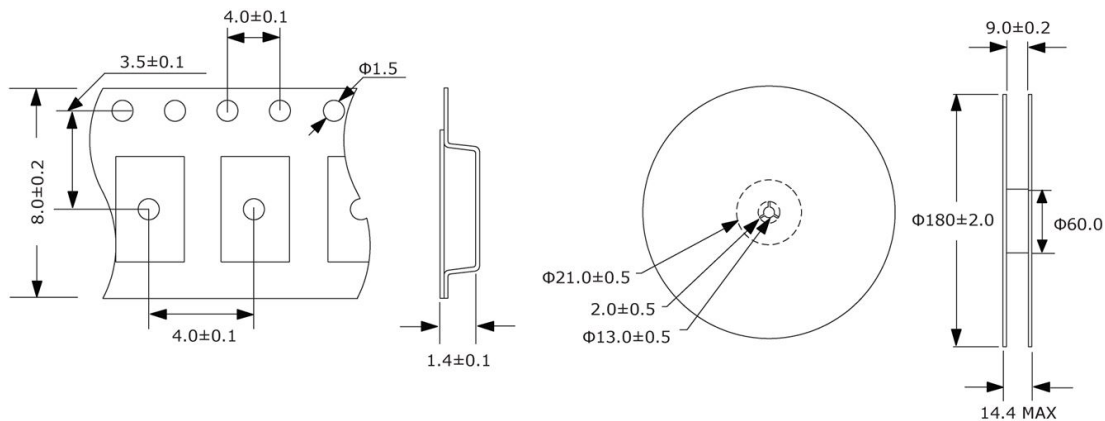

Environmental Specifications		Mechanical Specifications	
Temperature Cycling	MIL-STD-883, Method 1010, Condition B	Mechanical Shock	MIL-STD-202, Method 213, Condition B
Fine Leak Test	MIL-STD-883, Method 1014, Condition A	Vibration	MIL-STD-883, Method 2007, Condition A
Gross Leak Test	MIL-STD-883, Method 1014, Condition C	Moisture Resistance	MIL-STD-883, Method 1004
Solderability	MIL-STD-883, Method 2003	Resistance to Solvents	MIL-STD-202, Method 215
Moisture Sensitivity	J-STD-020, MSL 1	Resistance to Soldering Heat	MIL-STD-202, Method 210, Condition K