

SOT-23 Plastic-Encapsulate Transistors

MMBTA92 TRANSISTOR (PNP)

FEATURES

High voltage transistor

MARKING:2D

MAXIMUM RATINGS ($T_a=25^\circ\text{C}$ unless otherwise noted)

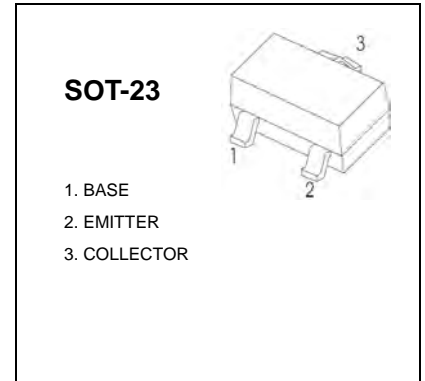

Symbol	Parameter	Value	Unit
V_{CBO}	Collector-Base Voltage	-300	V
V_{CEO}	Collector-Emitter Voltage	-300	V
V_{EBO}	Emitter-Base Voltage	-5	V
I_C	Collector Current -Continuous	-200	mA
I_{CM}	Collector Current -Pulsed	-500	mA
P_C	Collector Power Dissipation	300	mW
T_j	Junction Temperature	150	$^\circ\text{C}$
T_{stg}	Storage Temperature	-55-150	$^\circ\text{C}$
$R_{\theta JA}$	Thermal Resistance, junction to Ambient	410	$^\circ\text{C}/\text{mW}$

ELECTRICAL CHARACTERISTICS ($T_a=25^\circ\text{C}$ unless otherwise specified)

Parameter	Symbol	Test conditions	Min	Max	Unit
Collector-base breakdown voltage	$V_{(BR)CBO}$	$I_C = -100\mu\text{A}, I_E = 0$	-300		V
Collector-emitter breakdown voltage	$V_{(BR)CEO}$	$I_C = -1\text{mA}, I_B = 0$	-300		V
Emitter-base breakdown voltage	$V_{(BR)EBO}$	$I_E = -100\mu\text{A}, I_C = 0$	-5		V
Collector cut-off current	I_{CBO}	$V_{CB} = -200\text{V}, I_E = 0$		-0.25	μA
Emitter cut-off current	I_{EBO}	$V_{EB} = -5\text{V}, I_C = 0$		-0.1	μA
DC current gain	$h_{FE(1)}$	$V_{CE} = -10\text{V}, I_C = -1\text{mA}$	60		
	$h_{FE(2)}$	$V_{CE} = -10\text{V}, I_C = -10\text{mA}$	100	200	
	$h_{FE(3)}$	$V_{CE} = -10\text{V}, I_C = -30\text{mA}$	60		
Collector-emitter saturation voltage	$V_{CE(sat)}$	$I_C = -20\text{mA}, I_B = -2\text{mA}$		-0.2	V
Base-emitter saturation voltage	$V_{BE(sat)}$	$I_C = -20\text{mA}, I_B = -2\text{mA}$		-0.9	V
Transition frequency	f_T	$V_{CE} = -20\text{V}, I_C = -10\text{mA}$ $f = 30\text{MHz}$	50		MHz



Typical Characteristics

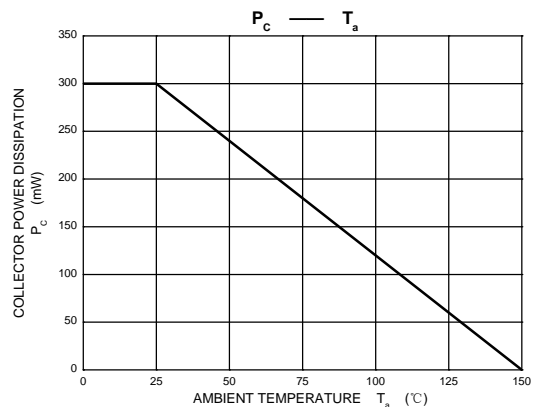
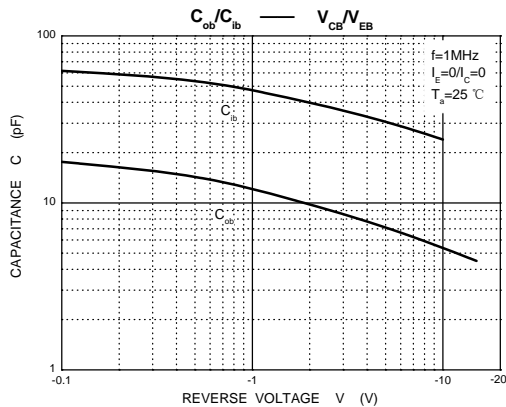
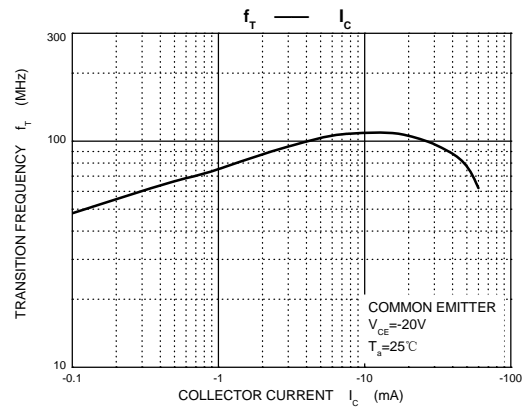
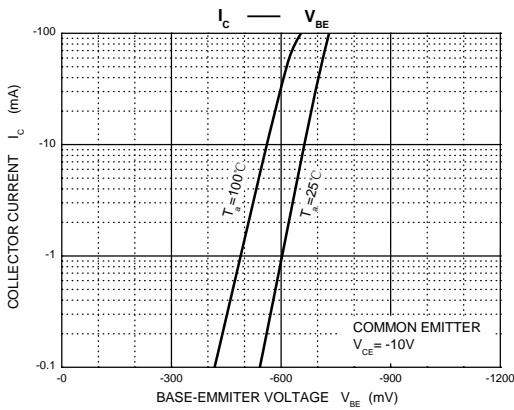
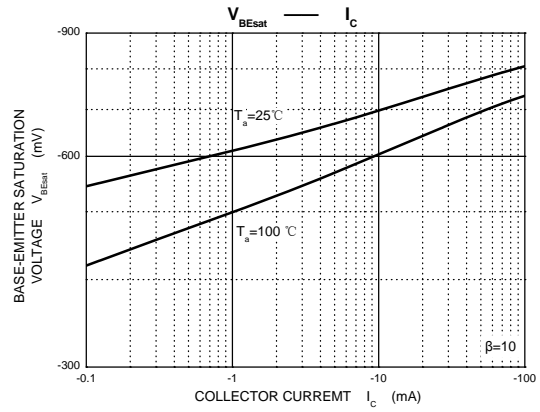
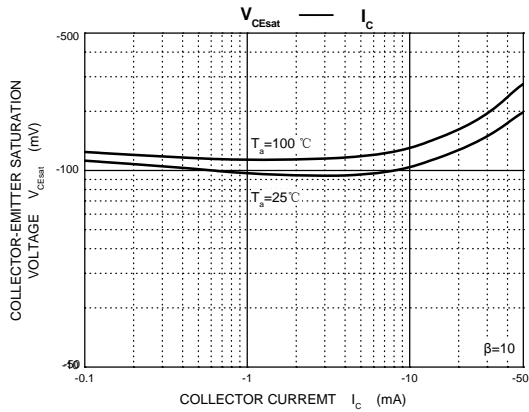
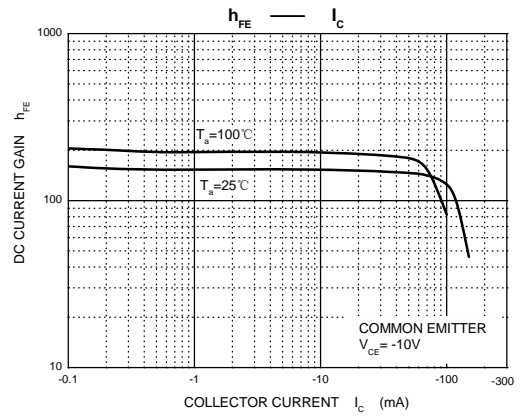
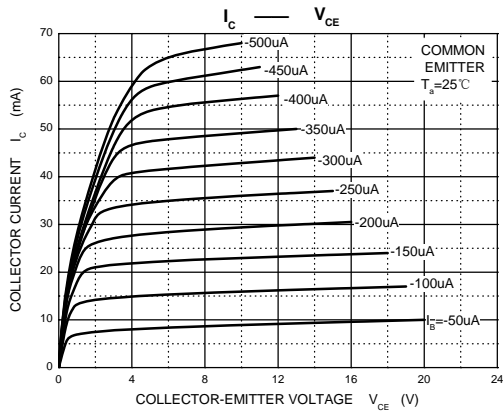

PACKAGE OUTLINE

Plastic surface mounted package; 3 leads

SOT-23

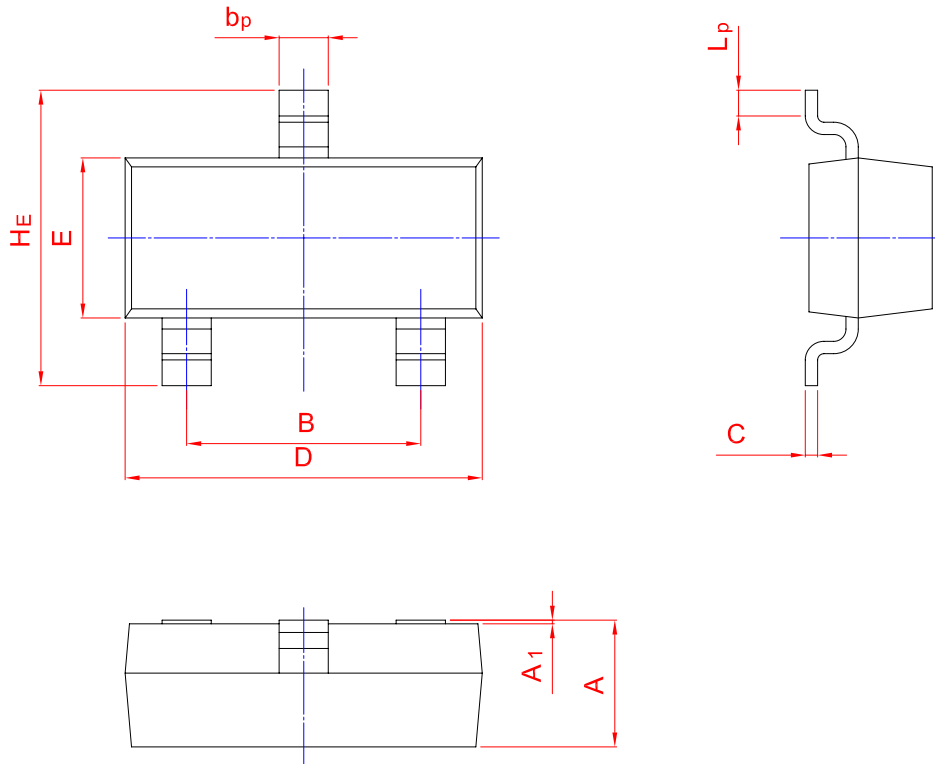
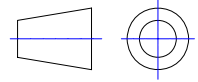

UNIT	A	B	b _p	C	D	E	H _E	A ₁	L _p
mm	1.40	2.04	0.50	0.19	3.10	1.65	3.00	0.100	0.50
	0.95	1.78	0.35	0.08	2.70	1.20	2.20	0.013	0.20