

rakon Digital pulse compression module

CI F04 / CI F05 Compressor

To make an enquiry please email: info@rakon.fr

Product description

CI F04 and CI F05 are digital pulse compressors that perform matched filtering of a radar return signal. CI F04 is a stand alone single channel compressor with IF analog I/Os while CI F05 is a dual channel compressor with IF analog I/Os.

Both products may be customized to match linear or non linear chirps to generate compressed pulse.

CI F0x may be used as a replacement of existing SAW based pulse compressor to overcome device obsolescence or enhance RADAR performances.

CI F0x compressor behavior and performances are reproducible from one unit to the other. No matching is needed.

Rakon-Temex will customize pulse compression filter according to the characteristics requested by the customer (Chirp duration, bandwidth, compressed pulse width, chirp slope ...).

The compressor unit is provided with FPGA firmware loaded, including pulse compression filter.

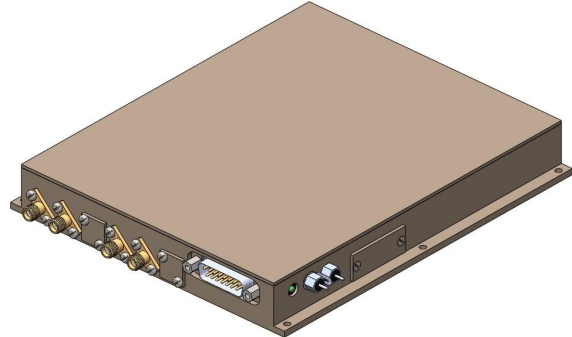

Features

- Digital pulse compression unit
- CI F04 : One compressor channel with IF analog I/Os
- CI F05 : Two independent compressor channels with IF analog I/Os
- 2 selectable waveforms for each channel
- High precision clock
- BITE function
- High BxT compression gain

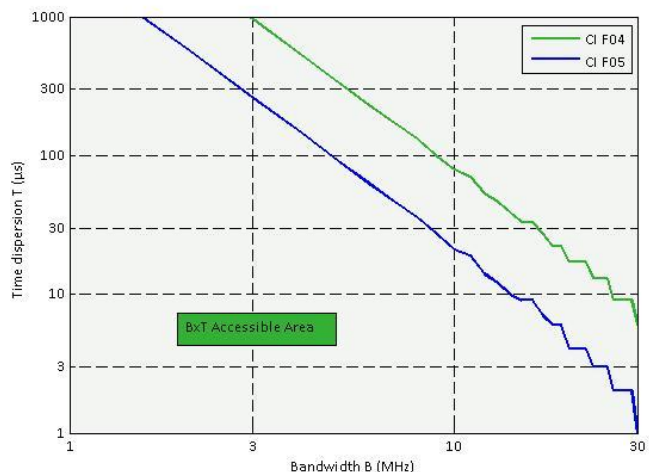

Applications

- SAW based pulse compression RADARS upgrade

Note: In this entire document, CI F0x stands for CI F04 or CI F05

March 15th, 2013

Technical description

CI F04 compressor functional block diagram is featured on Fig. 1 while CI F05 block diagram is featured on Fig. 2.

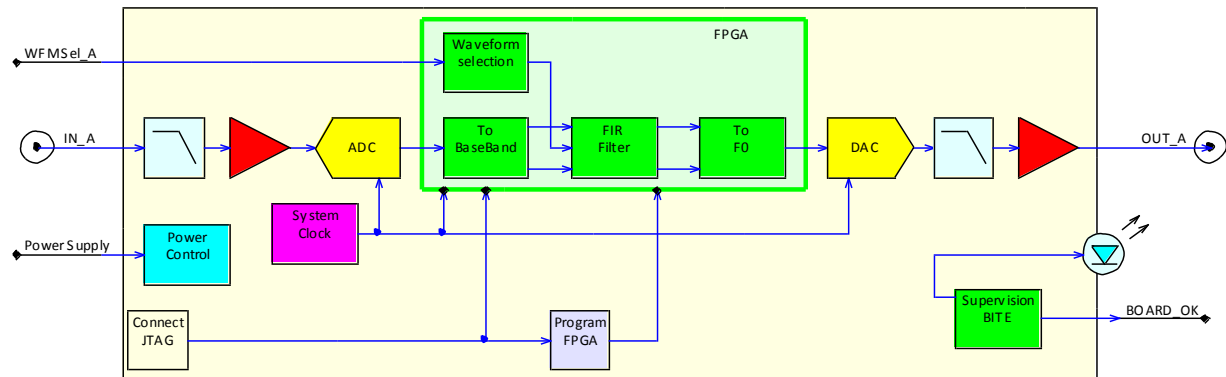

Fig. 1 : CI F04 compressor functional block diagram

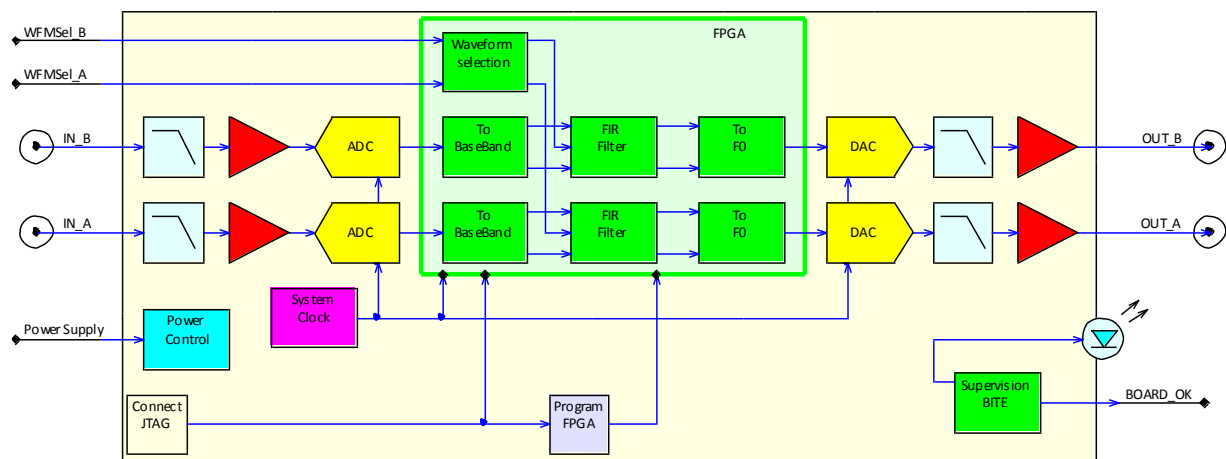

Fig. 2 : CI F05 compressor functional block diagram

Input chirps are filtered (anti-aliasing filter), sampled and down-converted to baseband. I and Q baseband data are processed by FIR filters whose coefficients are matched with the expander chirp characteristics. Digital baseband I/Q compressed pulse is then up-converted to carrier frequency and converted into analog signal.

As inputs and outputs are IF analog signals, CI F0x are well suited to upgrade SAW based pulse compression Radars. For better compatibility with old SAW based subsystems, an adjustable additional delay may be inserted.

CI F05 unit is able to process on-the-fly 2 independent and concurrent channels. Fig. 3 gives the maximum chirp duration value vs. bandwidth achievable for each channel. Consider for B the maximum bandwidth value of the 2 waveforms, and for T the maximum time duration value of the 2 waveforms.

The internal low noise system clock is self-sufficient, and does not need to be referenced on any external clock.

CI F0x unit is provided with FPGA firmware loaded. Functions, and channels specifications (time dispersion, compressed pulse width, side lobes level...) should be provided by customer; Rakon-Temex will customize the FPGA program to fulfill customer requirements.

For each channel, waveform is selected among 2 possible waveforms, using WFMSel_x inputs, as presented in Table 1 and Table 2. Each time WFMSel_x signal changes, the new set of waveform coefficients will be active 50 μ s later.

CI F0x unit continuously monitors internal power supply and FPGA program integrity. If voltage exceeds nominal levels, or if FPGA program is corrupted, BITE output is deasserted, and LED is turned off. The BITE output indicates the GO-NOGO state of the compressor.

Table 1 : Waveform A selection

WFMSel_A	Waveform
0	Waveform A0 (TBD)
1	Waveform A1 (TBD)

Table 2 : Waveform B selection (CI F05 only)

WFMSel_B	Waveform
0	Waveform B0 (TBD)
1	Waveform B1 (TBD)

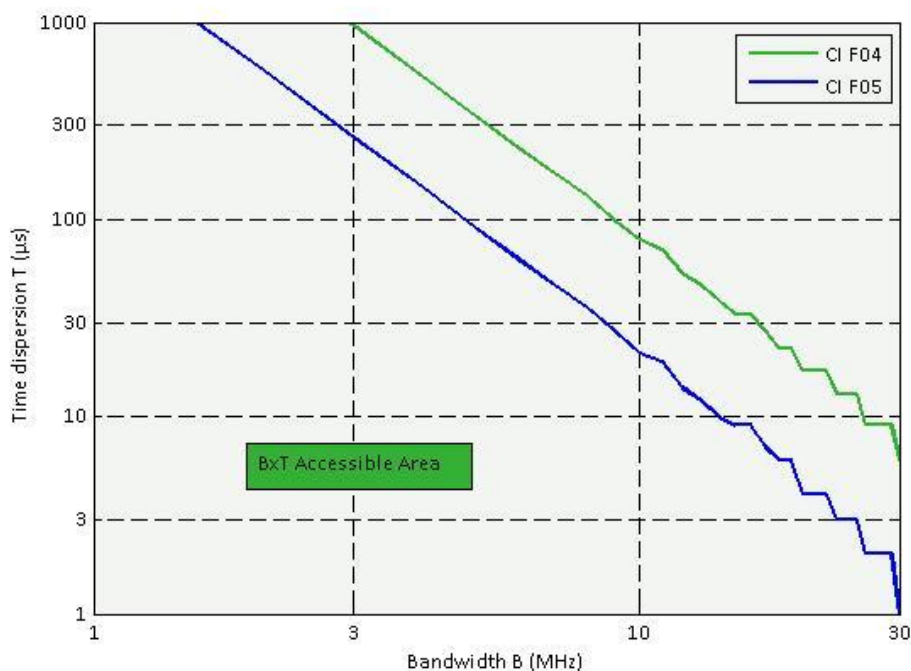

Fig. 3 : Accessible B x T area

Specifications

1 Environmental conditions

Line	Parameter	Test Condition	Min.	Typ.	Max.	Unit
Procedures and conditions refer to MIL-STD-810G						
1.1	Temperature operating		-25		+60	°C
1.2	Temperature storage		-40		+85	°C
1.3	Humidity operating	@ 30 °C, (non condensing)			95	% RH
1.4	Shock	11 ms, 3 axes, 2 dir, half sine pulse			30	g
1.5	Random Vibration	20 to 500 Hz, 3 axes			0.1	g ² /Hz
1.6	EMI - EMC	In accordance with MIL-STD 461 E				

2 Electrical Interface

Line	Parameter	Test Condition	Min.	Typ.	Max.	Unit
Power supply						
2.1	Voltage		11		26	V
2.2	Current	@ Power supply = 15 V		600 ⁽¹⁾		mA
RF Input signals						
Refers to In_A, In_B						
2.3	Maximum input level			10		dBm
2.4	Input noise floor	Inside chirp bandwidth		-130		dBm/Hz
2.5	VSWR				1.3:1	
RF Output signals						
Refers to Out_A, Out_B						
2.6	Maximum output level			10		dBm
2.7	Output noise floor	Inside chirp bandwidth		-150		dBm/Hz
2.8	VSWR				1.3:1	
RS-422 control inputs						
Refers to WFMsel_A, WFMsel_B inputs						
2.9	Impedance			120		Ω
2.10	Setup time	To clock rising edge	50			ns
2.11	Hold time	From clock rising edge	50			ns

¹ Current highly depends on waveform characteristics (B, T, ...)

3 CI F04 compressor operation Performances

Line	Parameter	Test Condition	Min.	Typ.	Max.	Unit
	Note: Values given bellow are typical values given as a rough guide. Depending on the required parameters (B, T,...) other limitations may rise, e.g. side lobe levels highly depends on bandwidth (B) and time dispersion (T), τ_{-3dB} highly depends on bandwidth (B), ...					
3.1	Center frequency (F0)				100 – B/2	MHz
3.2	Maximum bandwidth (B)			45		MHz
	Maximum time dispersion (T)					
3.3	B < 3 MHz			950		μ s
3.4	B < 7 MHz			170		μ s
3.5	B < 20 MHz			17		μ s
3.6	Minimum compressed pulse width @ -3 dB (τ_{-3dB})			35		ns
3.7	Side lobe level (SLL)			35 to 45		dB
3.8	Minimal Compressor delay (TC)	Measured from the center of the input chirp, to the center of the compressed pulse output		T/2 + 2.5		μ s
3.9	Maximal additional Compressor delay (TC)	Measured from the center of the input chirp, to the center of the compressed pulse output		1		ms
3.10	CW Insertion loss @ F0			10		dB
3.11	Modulation slope		Up-chirp / Down-chirp			
3.12	Modulation type		Linear / Non linear			

4 CI F05 compressor operation Performances

Line	Parameter	Test Condition	Min.	Typ.	Max.	Unit
	Note: Values given bellow are typical values given as a rough guide. Depending on the required parameters (B, T,...) other limitations may rise, e.g. side lobe levels highly depends on bandwidth (B) and time dispersion (T), τ_{-3dB} highly depends on bandwidth (B), ...					

The following parameter apply to each of the 2 channels (A and B)

4.1	Center frequency (F0)				100 – B/2	MHz
4.2	Maximum bandwidth (B)			29		MHz
	Maximum time dispersion (T)					
4.3	B < 3 MHz			260		μ s
4.4	B < 7 MHz			45		μ s
4.5	B < 20 MHz			4		μ s
4.6	Minimum compressed pulse width @ -3 dB (τ_{-3dB})			35		ns
4.7	Side lobe level (SLL)			35 to 45		dB
4.8	Minimal Compressor delay (TC)	Measured from the center of the input chirp, to the center of the compressed pulse output		T/2 + 2.5		μ s
4.9	Maximal additional Compressor delay (TC)	Measured from the center of the input chirp, to the center of the compressed pulse output		1		ms
4.10	CW Insertion loss @ F0			25		dB
4.11	Modulation slope		Up-chirp / Down-chirp			
4.12	Modulation type		Linear / Non linear			

Mechanical features

5 Mechanical features

Line	Parameter	Test Condition	Min.	Typ.	Max.	Unit
5.1	Unit outline without connectors		185 x 152 x 27.1			mm ³
5.2	Unit weight		< 0.6			kg
5.3	Material		AG4.5MC			
5.4	Treatment		Ni15 / Zn1			
5.5	Screws		A4-70 stainless steel			

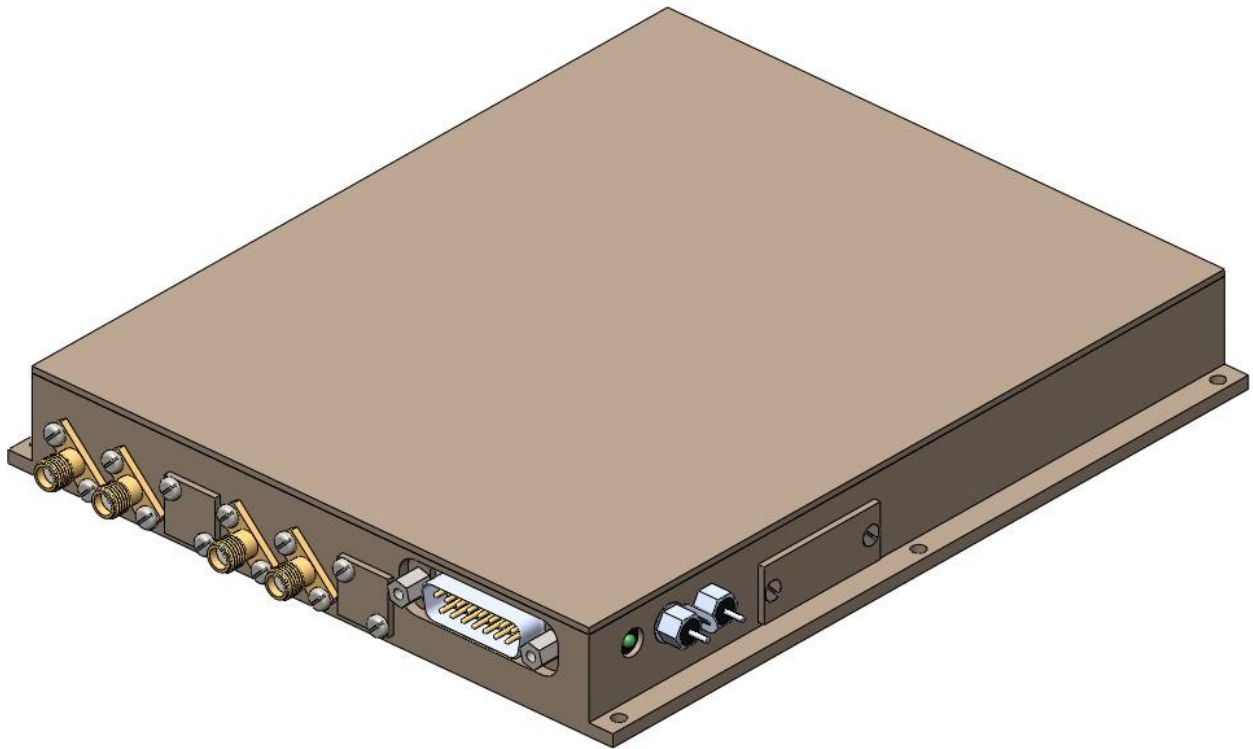

Fig. 4 : Mechanical drawing (connectors position TBC)

Reliability

6 Reliability information

Line	Parameter	Test Condition	Value	Unit
6.1	Estimated mean time between failure	FIDES 2004, 30°C ambient	> 250 000	H

Interfaces description

7 Interfaces description

Line	Pin number	Name	Description
J1 to J4 : SMA – Jack			
7.1	J1	In_A	RF chirp input AC, 50 Ω
7.2	J2 (CI F05 only)	In_B	RF chirp input AC, 50 Ω
7.3	J3	Out_A	RF compressed pulse output AC, 50 Ω
7.4	J4 (CI F05 only)	Out_B	RF compressed pulse output AC, 50 Ω
FL01 to FL02 : By-pass filter			
7.5	FL01	Power supply	Power supply
7.6	FL02	Power supply return	Power supply return
P1 : MIL-C-24308 15-pin SubD Connector			
7.7	P1 – 3 / P1 – 11	WFMSel_A +/-	Channel A Waveform selection input RS-422 compatible input, 120 Ω differential impedance
7.8	P1 – 4 / P1 – 12 (CI F05 only)	WFMSel_B +/-	Channel B Waveform selection input RS-422 compatible input, 120 Ω differential impedance
7.9	P1 – 5 / P1 – 13	Unit_OK +/-	BITE output RS-422 level, Logic 1 = Unit OK Indicates the GO-NOGO state of the unit
7.10	P1 – 15	OC Unit OK	Open Collector BITE Input-Output TTL Level with 300 Ω internal pull-up, Logic 1 = Unit OK Indicates the GO-NOGO state of the unit May be tied to other OC Unit OK to generate a global System OK when 2 or more CI F06 units are used
P3 : MOLEX type 87833-1420			
7.11	P3	JTAG	JTAG interface for program download