

IPPC-104D-2R

10.4" LED Industrial Panel PC with intel® ATOM

(Dual-core 1.8G) Processor



Features

1. 10.4" LED Panel support 800 × 600pixels
2. Intel Atom D525 (Dual-core 1.8GHz processor) CPU with 667 MHz FSB
3. Front 6mm aluminum bezel with IP65 compliant
4. Front hardness glass protect screen (touch option)
5. 3COM (1xRS485), 1xLPT, 2x PS/2, 1xVGA, 4xUSB, 2xLAN, 1x AUDIO、MIC
6. 1 xMini PCIe slot
- 7.Back For Power LED and HDD LED Indication
8. Wireless LAN with antenna (option)
9. Panel (Flush) mount with clips
10. Wide range DC 8-30V input (option)
11. Standard VESA 75/100mm support stand ,wall mount and swing arm



I/O Appearance

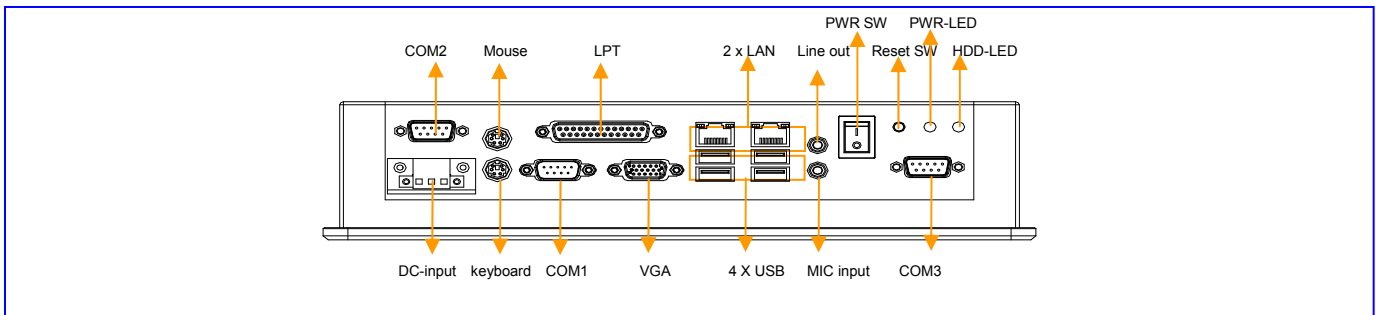

Various applications

1. Control or data entry operator interfaces
2. Information management and retrievals
3. Entertainment management systems
4. Point of sale (POS) terminals
5. Banking /office automation

Specifications

System	CPU	Intel Atom D525 (Dual-core 1.8GHz processor) CPU with 667 MHz FSB
	Chipset	Intel Atom D525 +ICH8M
	Memory	1x SODIMM DDR3 800/1066/1333 SDRAM up to 4 GB
	HDD	Space for 1x 2.5" 320G SATA HDD
	Ethernet	Two LAN onboard: 2x Realtek ® RL8111x (Gigabit) 10/100/1000Ethernet
	Graphic	Intel GMA3150 chipset
	Audio	Realtek ® ALC662, 5.1 channel surround audio
	Mounting	Panel / VESA 75 X 75mm and 100 x 100mm
	Construction	Aluminum front bezel and Aluminum chassis
	DimensionWxHxD (mm)	287.4 x 227.4 x 68mm
	Weight (kgs)	4.5KG

IPPC-104D-2R

10.4" Industrial Panel PC with intel® ATOM
(Dual-core 1.8G) Processor

OS support	Support DOS, Windows, Netware, Unix, Linux,	
I/O Ports	Serial ports	1 x RS-232, 1 x RS422/485
	Parallel ports	1 x SPP/EPP/ECP port
	Keyboard and Mouse ports	PS/2
	VGA	DB-15 Connector
	Sound	Mic-in / Line-out
	Ethernet	2 x 10/100/1000MLAN port (RJ-45)
	USB port	4 x USB2.0
	DC input Connector	3Pin DC power input terminal block
Environmental Specifications	Operating Temperature	0 °C to 45°C (32 °F~113 °F)
	Storage temperature	-20 °C to 60 °C (-4 °F~140 °F)
	Relative Humidity	10% to 90% non-condensing
	Shock (operating)	1G /peak (11m sec)
	Vibration	17 to 500HZ 1G PTP
	Front panel protection	IP65/NEMA 4 compliant
LCD Display	Display Type	10.4 LED panel
	Screenresolution (Pixels)	800 * 600
	Brightness	250cd/m2
	Viewing angle	160°(H) , 140°(V)
Touch screen	Internal USB interface controller	
	Resolution: continuous	
	Light transmission: 80% or more	
	Surface hardness : 3H	
	Operating force : ≤100g	
	Life expectancy : 35 Million	
Power Supply	Support DOS, Windows, Netware, Unix, Linux,	
	Output Rating	30W
	Input Voltage	8~30v, *External AC adapter*

Ordering Information

IPPC-104D-2R	10.4" LED Industrial Panel PC support Intel® Atom D525 Dual-core 1.8GHz Processor, with 2G/4G RAM, 2.5" 320G HDD/16G SSD, with Resistive Touch Screen, DC12V/DC8-30V power
MP-MS150NW	Mini-PCIE wireless Lan card with antenna

Dimension Diagram

