

ATLANTIC VERSION TERMINATOR INTERFACE ADAPTER	PART NUMBER	REVISION	DESCRIPTION	FEED TYPE	APPLICATOR STYLE CONVERSION CHART						
					CONVERT TO	PART NUMBERS REQUIRED					
	2151683-2	C	FINE CRIMP HEIGHT ADJUST	PNEUMATIC	-	-	1338685-1	5-18022-5	-	-	-
	2151683-5	C	FINE CRIMP HEIGHT ADJUST	SERVO LATCH PLATE ⁴	SERVO LATCH PLATE	2119951-1	-	8-2151683-5	1901094-3	-	2168400-6 (QUANTITY 2)
	2151683-6	C	NON-CRIMP HEIGHT ADJUST	SERVO LATCH PLATE ⁴	PNEUMATIC FEED	2119950-1	1338685-1	5-18022-5	2119641-1	2119799-1	2063440-1
	2151683-7	C	FINE CRIMP HEIGHT ADJUST	NONE	-	-	-	-	-	-	-
	7-2151683-7	A	CRIMP TOOLING KIT	-	-	-	-	-	-	-	-

APPLICATOR DATA		
CRIMP SIZE	WIRE	INSUL
F	2.03 mm [.080]	2.79 mm [.110]
TYPE		
F		O

APPLICATOR INSTRUCTIONS
408-10389

TERMINAL DATA: TE TERMINAL		TE CRIMP SPECIFICATION	
TERMINAL NAME: TAB WITH DOUBLE LOCKING LANCE			
WIRE STRIP LENGTH		INSULATION DIAMETER RANGE	
4.80-4.80 mm [.189-.189 IN]		Ø1.40-2.00 mm [.055-.079 IN]	
TERMINAL APPLICATION SPECIFICATION	114-18022		
TERMINALS APPLIED ¹⁰			
TE TERMINAL	TE TERMINAL	TE TERMINAL	TE TERMINAL
962903-1	962903-2	962883-1	962883-2

WIRE SIZE	CRIMP HEIGHT mm [INCH]	CRIMP HEIGHT REFERENCE SETTING
1.00mm2	1.56+/-0.05 [.061+/-0.002]	3.0
0.75mm2	1.47+/-0.05 [.058+/-0.002]	4.0
0.50mm2	1.38+/-0.05 [.054+/-0.002]	4.9

- ¹ RECOMMENDED SPARE PARTS
- ² GREASE BEARING SURFACES LIGHTLY
- 3. LUBRICATE DAILY PER THE APPLICATOR INSTRUCTION SHEET SUPPLIED WITH THE APPLICATOR.
- ⁴ APPLICATOR SPECIFIC DATA TO BE ENTERED INTO BLANK MEMORY CHIP AT ASSEMBLY. SEE BELOW FOR PART NUMBER:
 PNEUMATIC FEED WITH "SMART APPLICATOR" CONVERSION: 8-2151683-4
 SERVO FEED WITH "FINE CRIMP HEIGHT ADJUST": 8-2151683-5
 SERVO FEED WITH "NON-CRIMP HEIGHT ADJUST": 8-2151683-6
- 5. ADJUSTMENT OF THE STRIPPER MAY BE REQUIRED WHEN MOVING THE APPLICATOR BETWEEN BENCH AND LEADMAKER APPLICATIONS.
- ⁶ APPLY PART NUMBER 1-23419-5 LOCTITE TO THREADS OF ITEMS 62. APPLY PART NUMBER 2-23419-6 LOCTITE TO THREADS OF ITEMS 242. FOR -6 ONLY APPLY PART NUMBER 1-23419-5 LOCTITE TO THREADS OF ITEM 37.
- ⁷ GREASE THREADS, GROOVE AND O-RING ON ITEMS 35 & 252.
- ⁸ MAGNET, ITEM 166 MUST BE ORIENTED CORRECTLY IN ORDER TO PROPERLY ACTUATE THE COUNTER.
- ⁹ CRIMP HEIGHT REFERENCE SETTING WAS THE SETTING USED WHEN THE APPLICATOR WAS QUALIFIED AT THE FACTORY. ADJUSTMENT MAY BE NECESSARY WHEN RUNNING APPLICATOR IN THE FIELD.
- ¹⁰ TERMINAL PITCH NOT COMPATIBLE WITH MECHANICAL FEED.
- ¹¹ TO CONVERT THE APPLICATOR TO A NON-CARRIER CUTTING STYLE, REMOVE ITEM 13 AND ATTACH TO THE LOCATION ON THE BACK SIDE OF THE HOUSING. REFER TO INSTRUCTION SHEET FOR ADDITIONAL INFORMATION.
- ¹² WHEN ASSEMBLING -6 NON-CRIMP HEIGHT ADJUST APPLICATOR USE SHIM PACK 2119957-2 TO ALIGN APPLICATOR'S MAXIMUM WIRE CRIMP HEIGHT AT NORMAL TERMINATOR SHUT HEIGHT
- ¹³ CUT TO LENGTH AT ASSEMBLY.

***WARNING**
 ON INSTALLATION, SET WIRE DISC, ITEM 40 TO LARGEST WIRE SIZE SETTING. USE OF SETTINGS BELOW MINIMUM REQUIRED CRIMP HEIGHT SETTING WILL CAUSE DAMAGE TO CRIMP TOOLING.

-77	-7	-6	-5	-2	PART NO	DESCRIPTION	ITEM NO
-	2	2	2	2	2168083-1	SCR, SKT HD CAP, RoHS, M3 X 8.0	264

ATLANTIC VERSION
 Shown on sheets 1 of 4 & 2 of 4
 (Pacific version shown on sheets 3 of 4 & 4 of 4)

SET UP GAUGE	LOC	DIST	REVISIONS			
2119599-1	A	66	REV	DATE	BY	APPV
			B	ECR-15-009671	25JUN2015	MR GB
			C	ECR-15-014379	30SEP2015	KH TE

REV	DATE	BY	APPV	DESCRIPTION	ITEM NO		
-	1	1	1	1633782-2	FENCE	263	
-	-	1	-	2119957-2	APPLICATOR SHIM PACK	260	
-	1	-	1	8-21084-0	O-RING, .676 ID, .070 DIA. MAT.	252	
-	-	-	1	2119640-1	PUSH ROD, AIR FEED	250	
-	-	-	1	2079988-1	BUSHING, LCH5-12, MISUMI	249	
-	-	-	1	2119641-1	FEED CAM, AIR FEED	248	
-	1	-	1	2119798-1	DETENT PIN	247	
-	1	-	1	1-22279-3	SPRING, COMPRESSION	246	
-	-	1	-	2119758-1	RAM, AMP STYLE, SIDE FEED, NON-ADJ.	245	
-	1	1	1	2119082-8	CAM, SNAIL, INSULATION ADJUSTMENT	244	
-	1	1	1	2079764-1	WASHER, WAVE SPRING, CREST-TO-CREST	243	
-	1	1	1	2119083-1	RETAINER, INSULATION DIAL	242	
-	1	1	1	7-18023-7	SCR, SKT HD CAP M3 X 4.0	241	
-	-	2	2	2168400-6	SHCS, LOW HEAD, RoHS, M5 X 16	240	
-	-	-	1	2063440-1	AIR FEED MODULE	238	
-	-	1	1	2119740-2	TAG, IDENTIFICATION	213	
-	-	1	1	1901094-3	SPACER, FEEDER	198	
-	-	-	2	21045-3	RING, RETAIN, EXTERN, 3/16 CRESCENT	172	
-	1	1	1	994969-1	MAGNET, RARE EARTH HIGH ENERGY	166	
-	REF	REF	REF	994970-2	COUNTER, MAGNETIC	164	
-	-	-	1	240638-1	SPRING, FEED FINGER	163	
-	-	-	1	3-23627-7	PIN, RETAIN, GRVD, 3/16 X .854	137	
-	-	-	1	2119799-1	HOLDER, FEED FINGER, AF	136	
-	-	REF	REF	-	SEE NOTE 4	135	
-	-	1	1	1633743-1	SERVO FEED LATCH ASM	133	
-	1	1	1	1-18028-2	WASHER, FLAT, REG M4	119	
-	-	REF	REF	-	2119944-1	FEED FINGER ASSEMBLY, SF	117
-	1	1	1	455888-5	SPACER, CRIMPER	82	
-	1	1	1	2119956-1	DOCUMENTATION PACKAGE	71	
-	1	-	-	2119740-1	TAG, IDENTIFICATION	67	
-	2	2	2	2168078-1	SCREW, DRIVE, RH, RoHS, 2 x .188	66	
-	1	-	1	2119793-1	LIMITER, ADJUSTMENT BOLT	63	
-	3	-	3	992763-5	SCR, SET, SOC, CONE POINT, M3 X 4.0	62	
-	1	1	1	2079383-4	SCR, BHSC, RoHS (M4 X 8)	60	
-	-	-	-	5-18022-5	SCR, HEX HD CAP, M4 X 6.0	59	
-	-	-	-	1338685-1	PAWL, FEED	56	
-	4	4	4	2168400-1	SHCS, LOW HEAD, RoHS, M4 X 12	54	
-	2	2	2	2168083-9	SCR, SKT HD CAP, RoHS, M4 X 20	53	
-	1	1	1	5018030-1	NUT, HEX, REG, RoHS, M3	52	
-	1	1	1	811242-5	BUMPER, HOLD DOWN	51	
-	1	1	1	690753-2	SPACER, TONKER	50	
-	-	-	-	18023-9	SCR, SKT HD CAP M4 X 6.0	49	
-	1	1	1	2119656-9	APPLICATOR BASIC ASSEMBLY, SF	46	
-	1	-	1	2119370-1	RAM, AMP STYLE, SIDE FEED	44	
-	1	1	1	2079383-7	SCR, BHSC, RoHS (M8 X 25)	41	
-	1	-	1	2119645-1	DISC, NUMBERED FA WIRE ADJUSTMENT	40	
-	1	-	1	2119957-1	APPLICATOR SHIM PACK	39	
-	1	1	1	2119644-1	RAM WASHER, PRECISION	38	
-	1	1	1	2119085-1	FA HEAD, ATLANTIC STYLE	37	
-	1	-	1	2119092-1	BOLT, ADJUSTMENT	35	
-	1	1	1	1752356-6	SUPPORT, TERMINAL	34	
-	2	2	2	2079383-5	SCR, BHSC, RoHS (M4 X 20)	33	
-	1	1	1	2161328-1	HEX HEAD, FLANGED, M5 X 8mm LONG	32	
-	1	1	1	1320908-3	SPACER, STRIP GUIDE	30	
-	1	1	1	2119959-2	ASSEMBLY, STRIP GUIDE	29	
-	1	1	1	1-455888-0	SPACER, CRIMPER	28	
-	1	1	1	1320928-2	STRIP GUIDE	24	
-	1	1	1	2168083-2	SCR, SKT HD CAP, RoHS, M4 X 8.0	21	
-	1	1	1	1-18028-2	WASHER, FLAT, REG M4	20	
-	1	1	1	2119533-1	STRIPPER, SIDE FEED	19	
-	1	1	1	2119806-1	INSERT, SHEAR	13	
-	1	1	1	3-22280-3	SPRING, COMPRESSION	12	
-	1	1	1	1-356885-4	STOP, SHEAR	11	
-	1	1	1	2119805-1	SHEAR HOLDER, FRONT	10	
-	1	1	1	318707-1	FLOATING SHEAR, FRONT	9	
-	1	1	1	2-1333204-4	ANVIL, COMBINATION	8	
-	1	1	1	1-240641-5	SPACER	7	
-	-	-	-	-	-	6	
-	1	1	1	2119757-8	DEPRESSOR, SHEAR	5	
-	1	1	1	238011-2	BLOCK, CRIMPER SPACER	4	
-	1	1	1	5-2119784-7	CRIMPER, INSULATION O PREMIUM	3	
-	1	1	1	1-455888-4	SPACER, CRIMPER	2	
-	1	1	1	1-456405-5	CRIMPER, WIRE PREMIUM	1	

DIMENSIONS:		TOLERANCES UNLESS OTHERWISE SPECIFIED:		DATE	REV	DESCRIPTION
mm	0 PLC ±0.5	1 PLC ±0.13	2 PLC ±0.013	19JUN2012	1	CRUZ
	3 PLC ±0.001	4 PLC ±0.0001	ANGLES ±0.001	19JUN2012	2	CRUZ
MATERIAL	FINISH	WEIGHT	SCALE	Customer Accessible Production Drawing		

STE TE Connectivity
 Harrisburg, PA 17105-3608

Product Name: Ocean Side Feed Applicator

Part Number: 00779

Drawing No: C-2151683

Scale: 1:2

Sheet: 1 of 4

Rev: C

LOC		DIST		REVISIONS			
A	66	P	LTM	DESCRIPTION	DATE	OWN	APVD
		-		SEE SHEET 1			

FEED TYPE

PNEUMATIC

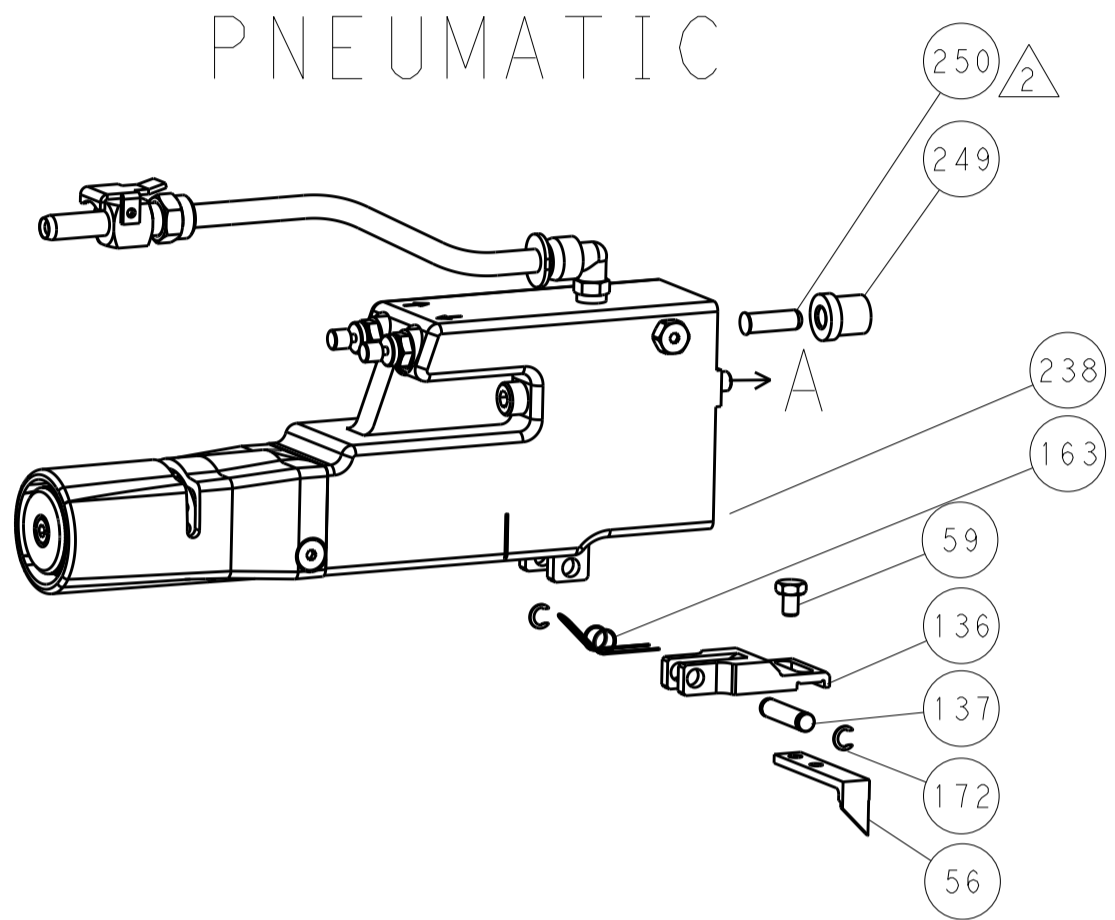

SERVO LATCH PLATE

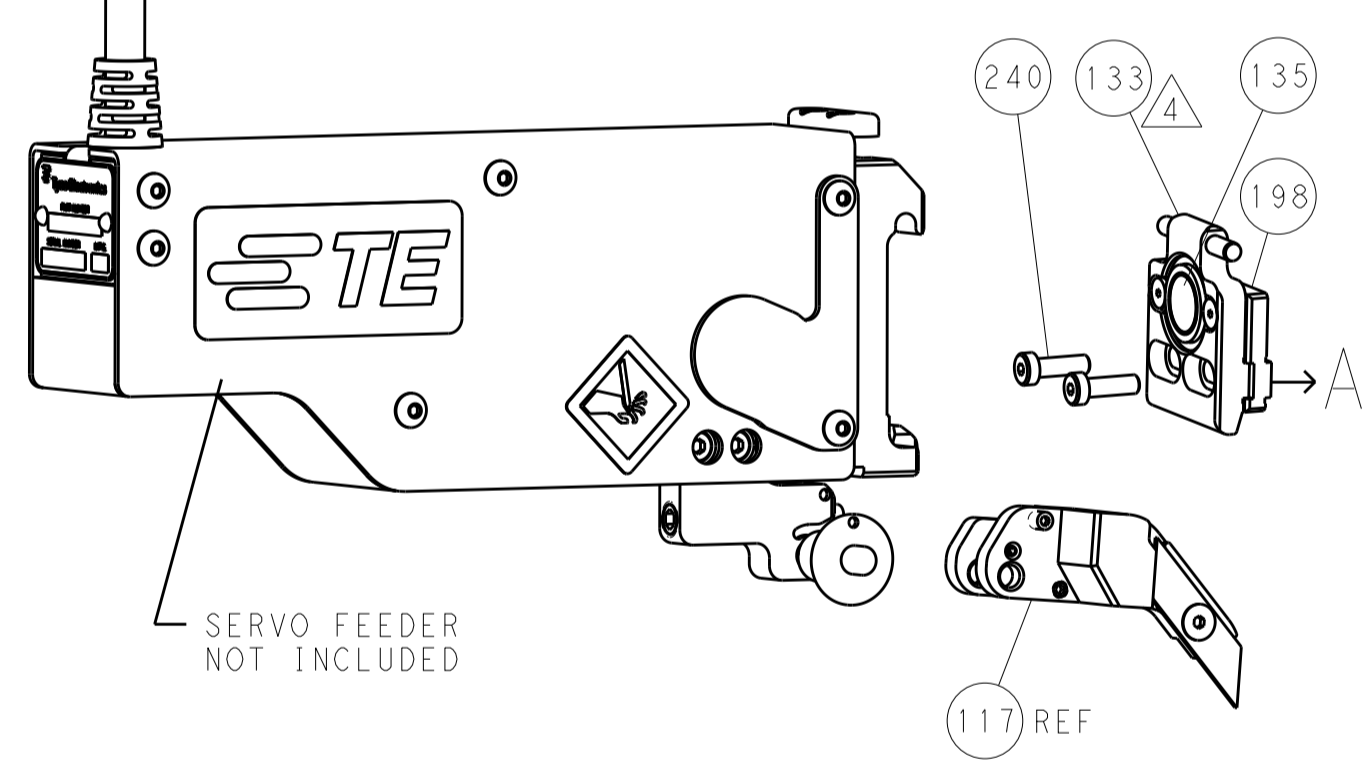

CAM POSITIONS

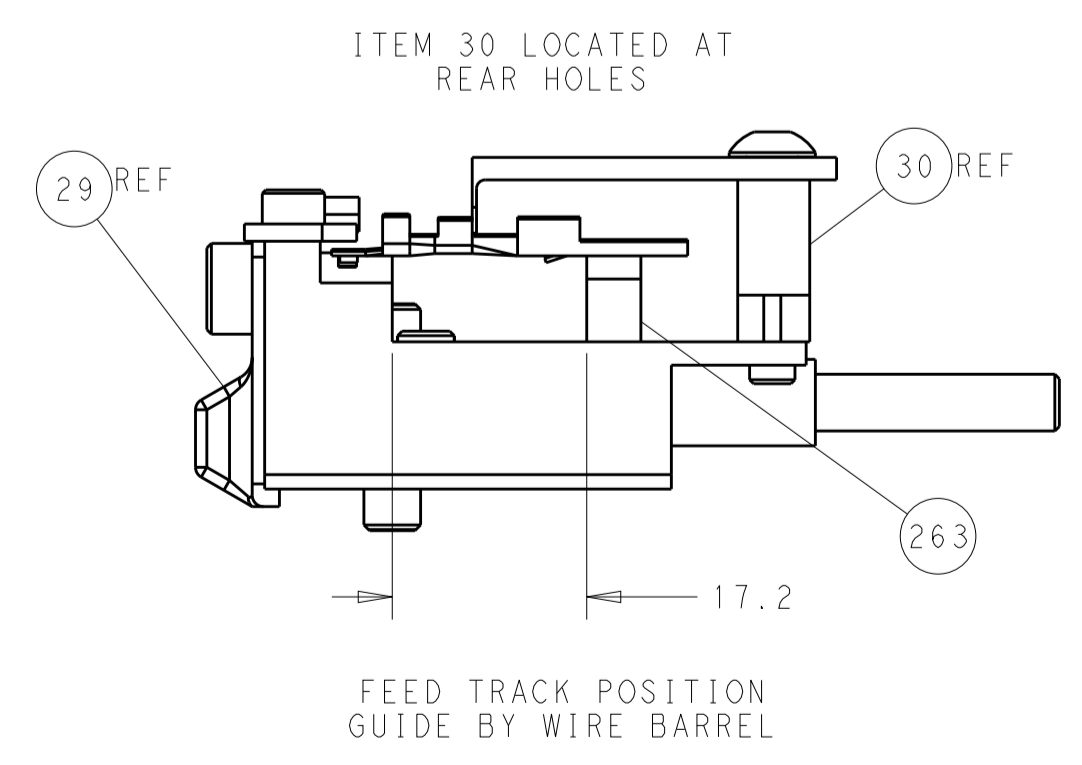
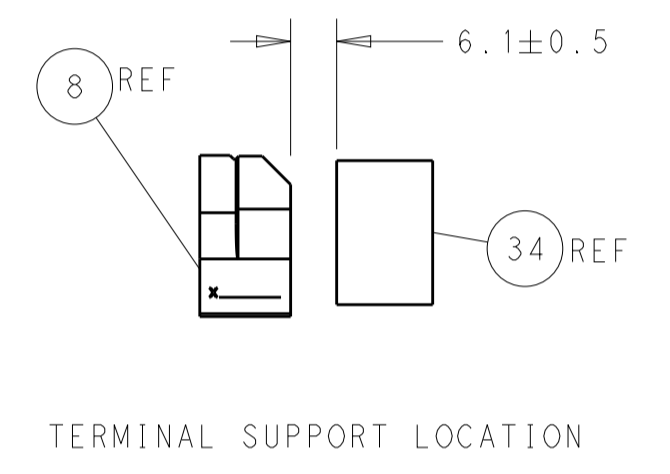
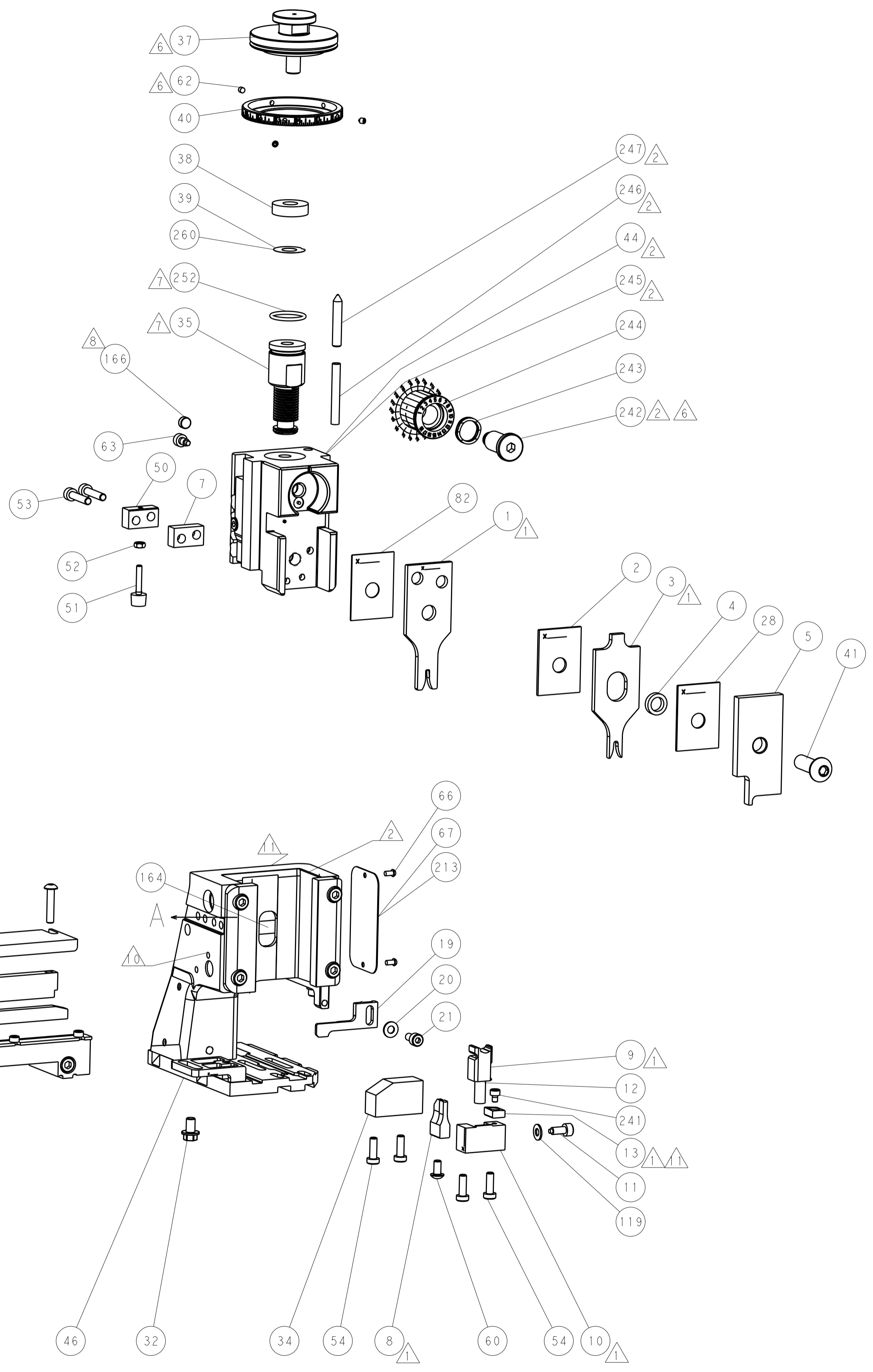
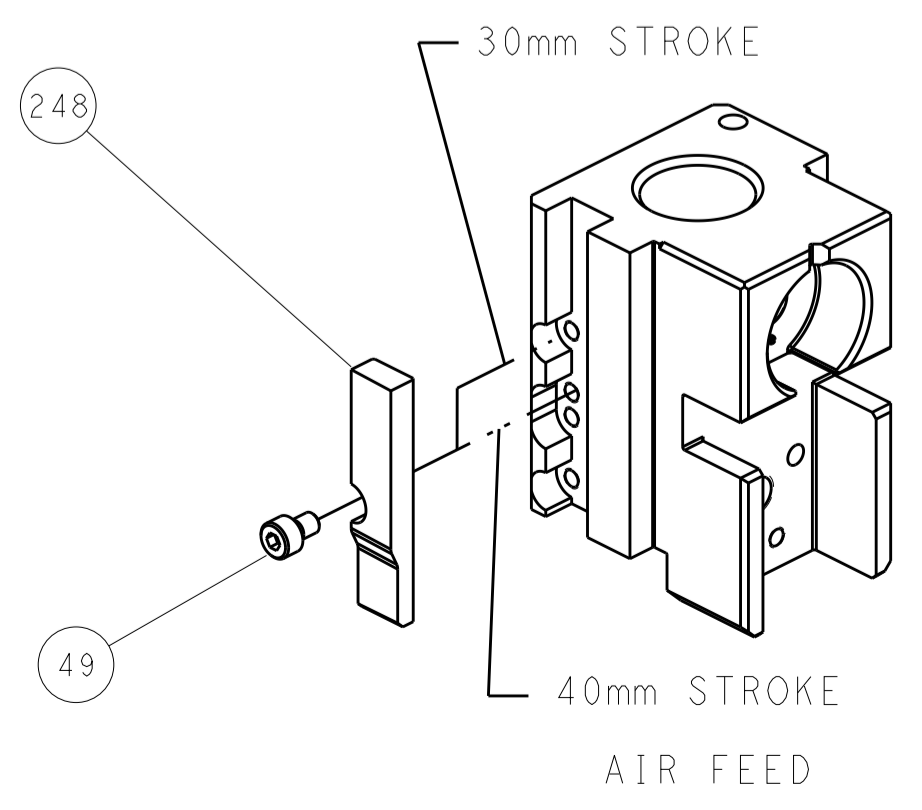

ATLANTIC VERSION
 Shown on sheets 1 of 4 & 2 of 4
 (Pacific version shown on sheets 3 of 4 & 4 of 4)

<small>THIS DRAWING IS UNPUBLISHED. RELEASED FOR PUBLICATION. IT IS THE PROPERTY OF TYCO ELECTRONICS CORPORATION. IT IS TO BE USED ONLY FOR THE PURPOSES AND IN THE QUANTITIES SPECIFIED IN THE ORDER. IT IS TO BE RETURNED TO TYCO ELECTRONICS CORPORATION WHEN NO LONGER REQUIRED.</small>		DWN: C. CHEN 19JUN2012 CHK: S. XI 19JUN2012 APVD: J. CRUZ 19JUN2012	TE Connectivity Harrisburg, PA 17105-3608
DIMENSIONS: mm TOLERANCES UNLESS OTHERWISE SPECIFIED: 0 PLC ±.5 1 PLC ±0.5 2 PLC ±0.13 3 PLC ±0.013 4 PLC ±0.001 ANGLES ±.1		NAME: Ocean Side Feed Applicator PRODUCT SPEC: APPLICATION SPEC: WEIGHT:	SIZE: A1 CAGE CODE: 00779 DRAWING NO: C=2151683 RESTRICTED TO:
MATERIAL:		FINISH:	SCALE: 1:2 SHEET: 2 OF 4 REV: C

PACIFIC VERSION TERMINATOR INTERFACE ADAPTER	PART NUMBER	REVISION	DESCRIPTION	FEED TYPE	APPLICATOR STYLE CONVERSION CHART					
					CONVERT TO	PART NUMBERS REQUIRED				
	2-2151683-2	C	FINE CRIMP HEIGHT ADJUST	PNEUMATIC	-	1338685-1	5-18022-5	-	-	-
					SERVO LATCH PLATE SMART APPLICATOR	2119951-1	-	8-2151683-5	1901094-3	-
	2-2151683-5	C	FINE CRIMP HEIGHT ADJUST	SERVO LATCH PLATE	-	1338685-1	5-18022-5	-	-	-
					PNEUMATIC FEED	2119950-1	1338685-1	5-18022-5	2119641-2	2119799-1
2-2151683-7	C	FINE CRIMP HEIGHT ADJUST	NONE	-	-	-	-	-	-	
7-2151683-7	A	CRIMP TOOLING KIT	-	-	-	-	-	-	-	

APPLICATOR DATA		
CRIMP	SIZE	TYPE
WIRE	2.03 mm [.080]	F
INSUL	2.79 mm [1.10]	O
APPLICATOR INSTRUCTIONS 408-10389		

TERMINAL DATA: TE TERMINAL		TE CRIMP SPECIFICATION	
TERMINAL NAME: TAB WITH DOUBLE LOCKING LANCE			
WIRE STRIP LENGTH		INSULATION DIAMETER RANGE	
4.80-4.80 mm [1.89-.189 IN]		Ø1.40-2.00 mm [0.055-.079 IN]	
TERMINAL APPLICATION SPECIFICATION	114-18022	-	-
TERMINALS APPLIED			
TE TERMINAL	TE TERMINAL	TE TERMINAL	TE TERMINAL
962903-1	962903-2	962883-1	962883-2

WIRE SIZE	CRIMP HEIGHT mm [INCH]	CRIMP HEIGHT REFERENCE SETTING
1.00mm2	1.56 +/- 0.05 [0.061 +/- .002]	3.0
0.75mm2	1.47 +/- 0.05 [0.058 +/- .002]	4.0
0.50mm2	1.38 +/- 0.05 [0.054 +/- .002]	4.9

- RECOMMENDED SPARE PARTS
- GREASE BEARING SURFACES LIGHTLY
- 3. LUBRICATE DAILY PER THE APPLICATOR INSTRUCTION SHEET SUPPLIED WITH THE APPLICATOR.
- APPLICATOR SPECIFIC DATA TO BE ENTERED INTO BLANK MEMORY CHIP AT ASSEMBLY. SEE BELOW FOR PART NUMBER:
 PNEUMATIC FEED WITH "SMART APPLICATOR" CONVERSION: 8-2151683-4
 SERVO FEED WITH "FINE CRIMP HEIGHT ADJUST": 8-2151683-5
- 5. ADJUSTMENT OF THE STRIPPER MAY BE REQUIRED WHEN MOVING THE APPLICATOR BETWEEN BENCH AND LEADMAKER APPLICATIONS.
- APPLY PART NUMBER 1-23419-5 LOCTITE TO THREADS OF ITEMS 62.
 APPLY PART NUMBER 2-23419-6 LOCTITE TO THREADS OF ITEMS 242.
- GREASE THREADS, GROOVE AND O-RING ON ITEMS 139 & 152.
- MAGNET MUST BE ORIENTED CORRECTLY IN ORDER TO PROPERLY ACTUATE THE COUNTER.
- CRIMP HEIGHT REFERENCE SETTING WAS THE SETTING USED WHEN THE APPLICATOR WAS QUALIFIED AT THE FACTORY. ADJUSTMENT MAY BE NECESSARY WHEN RUNNING APPLICATOR IN THE FIELD.
- TERMINAL PITCH NOT COMPATIBLE WITH MECHANICAL FEED.
- TO CONVERT THE APPLICATOR TO A NON-CARRIER CUTTING STYLE, REMOVE ITEM 13 AND ATTACH TO THE LOCATION ON BACK SIDE OF THE HOUSING. REFER TO INSTRUCTION SHEET FOR ADDITIONAL INFORMATION.
- CUT TO LENGTH AT ASSEMBLY.

***WARNING**
 ON INSTALLATION, SET WIRE DISC, ITEM 40 TO LARGEST WIRE SIZE SETTING. USE OF SETTINGS BELOW MINIMUM REQUIRED CRIMP HEIGHT SETTING WILL CAUSE DAMAGE TO CRIMP TOOLING.

PACIFIC VERSION
 Shown on sheets 3 of 4 & 4 of 4
 (Atlantic version shown on sheets 1 of 4 & 2 of 4)

SET UP GAUGE	LOC	DIST	REVISIONS					
2119599-1	A	66	P	LTN	DESCRIPTION	DATE	OWN	APVD
-	-	-	-	-	SEE SHEET 1	-	-	-

-	2	2	2	2168083-1	SCR, SKT HD CAP, RoHS, M3 X 8.0	264
-	1	1	1	1633782-2	FENCE	263
-	1	1	1	2119782-1	FINE ADJUST HEAD ASM, PACIFIC STYLE	251
-	-	-	1	2119640-1	PUSH ROD, AIR FEED	250
-	-	-	1	2079988-1	BUSHING, LCH5-12, MISUMI	249
-	1	1	1	1-22279-3	SPRING, COMPRESSION	246
-	1	1	1	2119082-8	CAM, SNAIL, INSULATION ADJUSTMENT	244
-	1	1	1	2079764-1	WASHER, WAVE SPRING, CREST-TO-CREST	243
	1	1	1	2119083-1	RETAINER, INSULATION DIAL	242
-	1	1	1	7-18023-7	SCR, SKT HD CAP M3 X 4.0	241
-	-	2	-	2168400-6	SHCS, LOW HEAD, RoHS, M5 X 16	240
-	-	-	1	2063440-1	AIR FEED MODULE	238
-	-	1	-	2119740-2	TAG, IDENTIFICATION	213
-	-	1	-	1901094-3	SPACER, FEEDER	198
-	-	-	2	21045-3	RING, RETAIN, EXTERN, 3/16 CRESCENT	172
	1	1	1	994969-1	MAGNET, RARE EARTH HIGH ENERGY	166
-	REF	REF	REF	994970-2	COUNTER, MAGNETIC	164
-	-	-	1	240638-1	SPRING, FEED FINGER	163
	1	1	1	8-21084-1	O-RING, .801 ID, .070 DIA. MAT.	152
-	-	-	1	2119641-2	FEED CAM, AIR FEED	151
-	1	1	1	2119798-2	DETENT PIN	145
-	1	1	1	2079383-8	SCR, BHSC, RoHS (M4 X 16)	144
-	4	4	4	2168400-5	SHCS, LOW HEAD, RoHS, M4 X 20	143
-	1	1	1	1-2119656-0	APPLICATOR BASIC ASSEMBLY, SF	141
-	1	1	1	2119650-1	RAM, ASIAN STYLE, SIDE FEED	140
	1	1	1	2119092-2	BOLT, ADJUSTMENT	139
-	-	-	1	3-23627-7	PIN, RETAIN, GRVD, 3/16 X .854	137
-	-	-	1	2119799-1	HOLDER, FEED FINGER, AF	136
-	-	REF	-	SEE NOTE 4	MEMORY CHIP, PROGRAMMED	135
-	-	1	-	1633743-1	SERVO FEED LATCH ASM	133
-	1	1	1	1-18028-2	WASHER, FLAT, REG M4	119
-	-	REF	-	2119944-1	FEED FINGER ASSEMBLY, SF	117
-	1	1	1	455888-5	SPACER, CRIMPER	82
-	1	1	1	2119956-1	DOCUMENTATION PACKAGE	71
-	1	-	1	2119740-1	TAG, IDENTIFICATION	67
-	2	2	2	2168078-1	SCREW, DRIVE, RH, RoHS, 2 x .188	66
-	1	1	1	2119793-1	LIMITER, ADJUSTMENT BOLT	63
	3	3	3	992763-5	SCR, SET, SOC, CONE POINT, M3 X 4.0	62
-	-	-	1	5-18022-5	SCR, HEX HD CAP, M4 X 6.0	59
-	-	-	1	1338685-1	PAWL, FEED	56
	2	2	2	2168083-9	SCR, SKT HD CAP, RoHS, M4 X 20	53
-	1	1	1	5018030-1	NUT, HEX, REG, RoHS, M3	52
-	1	1	1	811242-5	BUMPER, HOLD DOWN	51
-	1	1	1	690753-2	SPACER, TONKER	50
-	-	-	1	18023-9	SCR, SKT HD CAP M4 X 6.0	49
-	1	1	1	2079383-7	SCR, BHSC, RoHS (M8 X 25)	41
-	1	1	1	2119645-1	DISC, NUMBERED FA WIRE ADJUSTMENT	40
-	1	1	1	2119957-1	APPLICATOR SHIM PACK	39
-	1	1	1	2119644-1	RAM WASHER, PRECISION	38
-	1	1	1	1752356-6	SUPPORT, TERMINAL	34
-	2	2	2	2079383-5	SCR, BHSC, RoHS (M4 X 20)	33
-	1	1	1	2161328-1	HEX HEAD, FLANGED, M5 x 8mm LONG	32
-	1	1	1	1320908-3	SPACER, STRIP GUIDE	30
-	1	1	1	2119959-2	ASSEMBLY, STRIP GUIDE	29
-	1	1	1	1-455888-0	SPACER, CRIMPER	28
-	1	1	1	1320928-2	STRIP GUIDE	24
-	1	1	1	2168083-2	SCR, SKT HD CAP, RoHS, M4 X 8.0	21
-	1	1	1	1-18028-2	WASHER, FLAT, REG M4	20
-	1	1	1	2119533-1	STRIPPER, SIDE FEED	19
	1	1	1	2119806-1	INSERT, SHEAR	13
-	1	1	1	3-22280-3	SPRING, COMPRESSION	12
-	1	1	1	1-356885-4	STOP, SHEAR	11
	1	1	1	2119805-1	SHEAR HOLDER, FRONT	10
	1	1	1	318707-1	FLOATING SHEAR, FRONT	9
	1	1	1	2-1333204-4	ANVIL, COMBINATION	8
-	1	1	1	1-240641-5	SPACER	7
-	-	-	-	-	-	6
-	1	1	1	2119757-8	DEPRESSOR, SHEAR	5
-	1	1	1	238011-2	BLOCK, CRIMPER SPACER	4
	1	1	1	5-2119784-7	CRIMPER, INSULATION O PREMIUM	3
-	1	1	1	1-455888-4	SPACER, CRIMPER	2
	1	1	1	1-456405-5	CRIMPER, WIRE PREMIUM	1

DIMENSIONS:		TOLERANCES UNLESS OTHERWISE SPECIFIED:		DRAWING NO	
mm	0 PLC ±.5	1 PLC ±0.5	2 PLC ±0.13	3 PLC ±0.013	4 PLC ±0.001
	ANGLES ±.0001	FINISH			
MATERIAL		FINISH			
Customer Accessible Production Drawing		SCALE	1:2	SHEET	3 OF 4

LOC		DIST		REVISIONS			
A	66	P	LTM	DESCRIPTION	DATE	DWN	APVD
		-		SEE SHEET 1			

FEED TYPE

PNEUMATIC

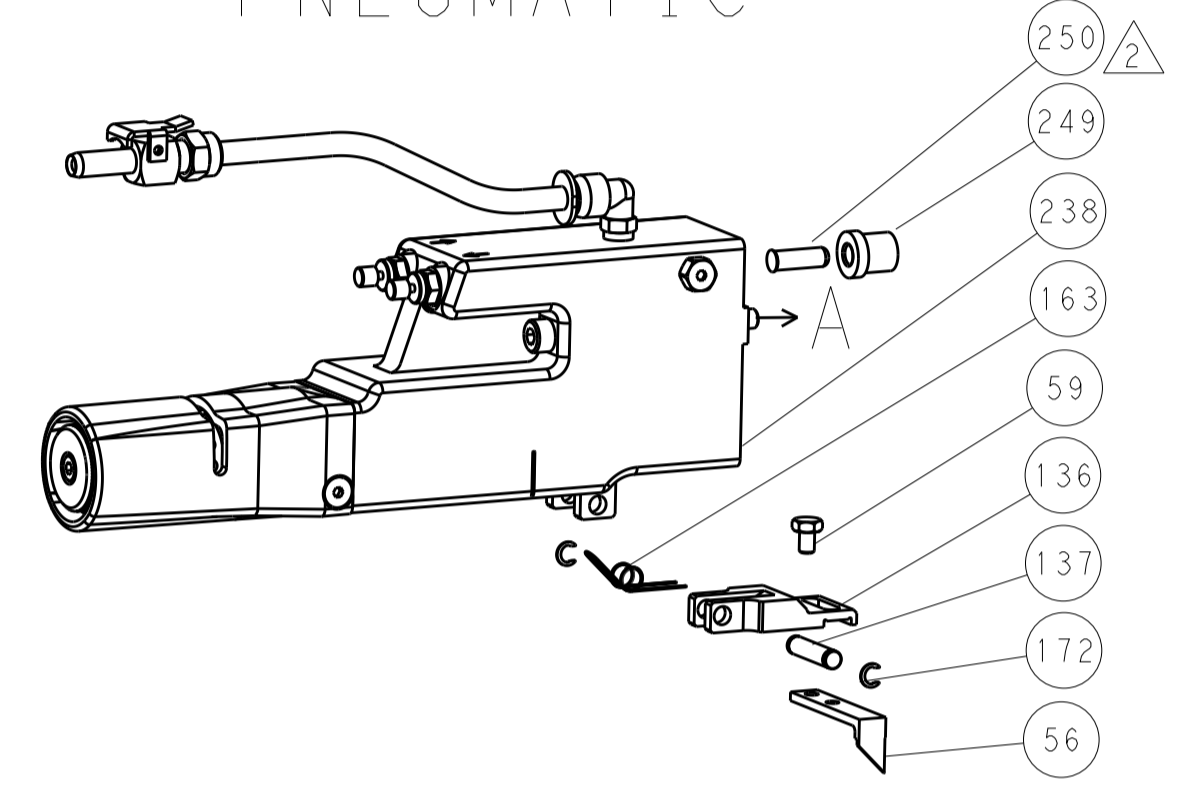

SERVO LATCH PLATE

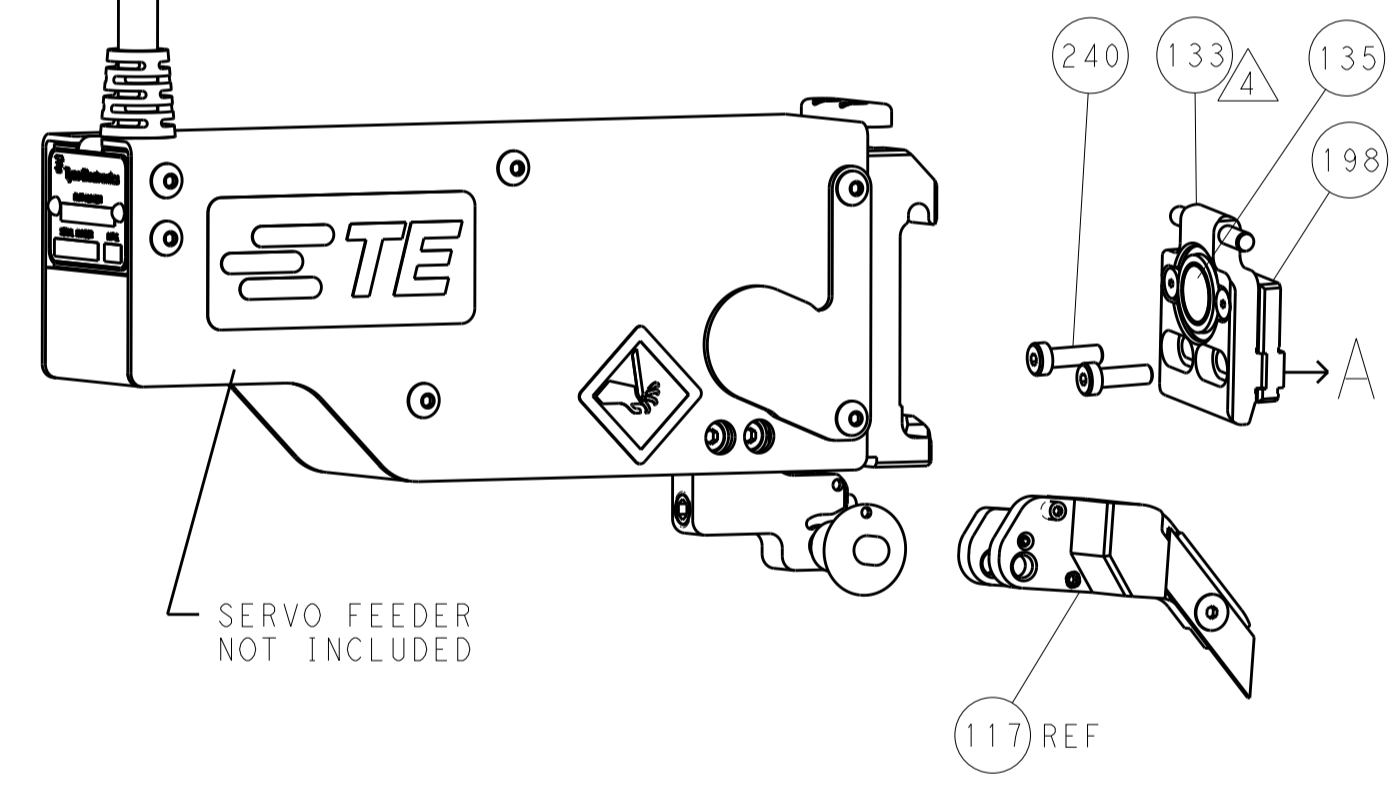

CAM POSITIONS

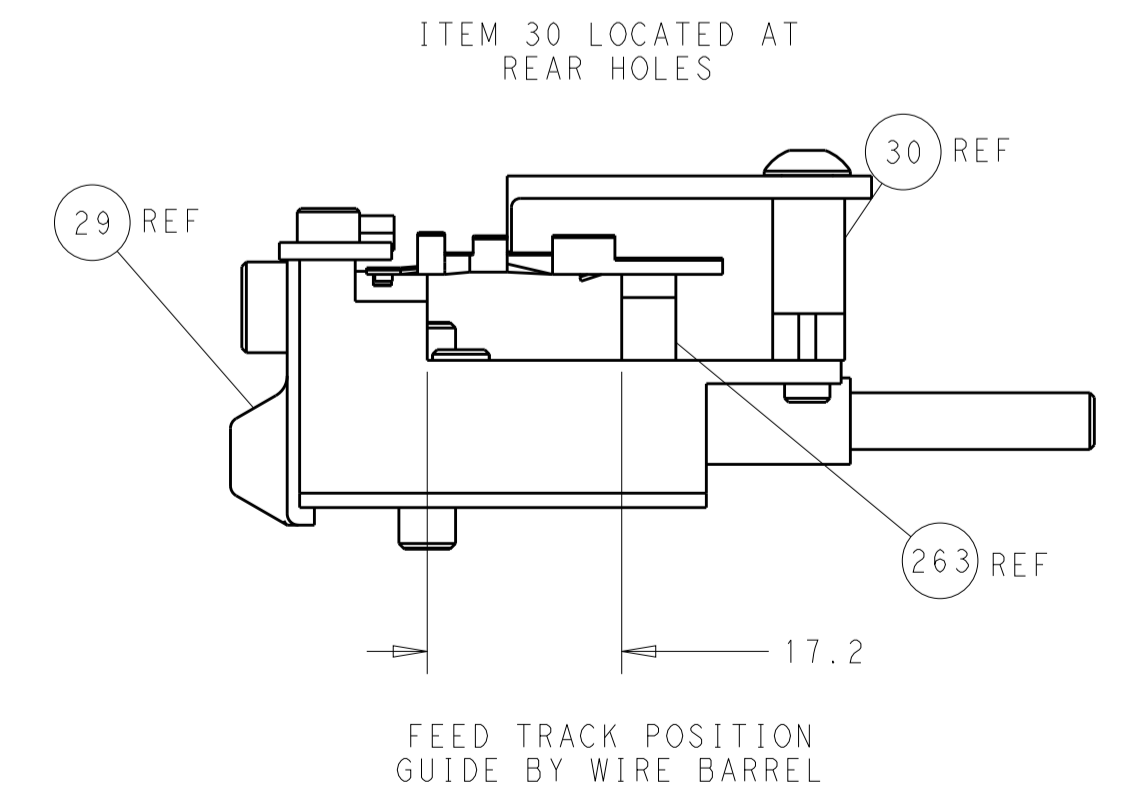
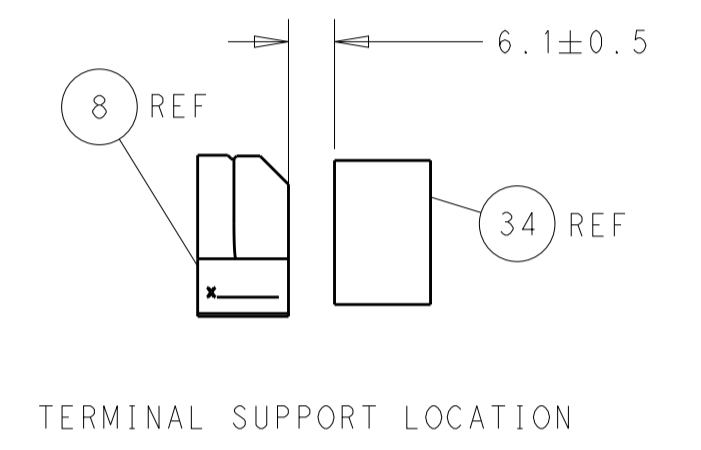
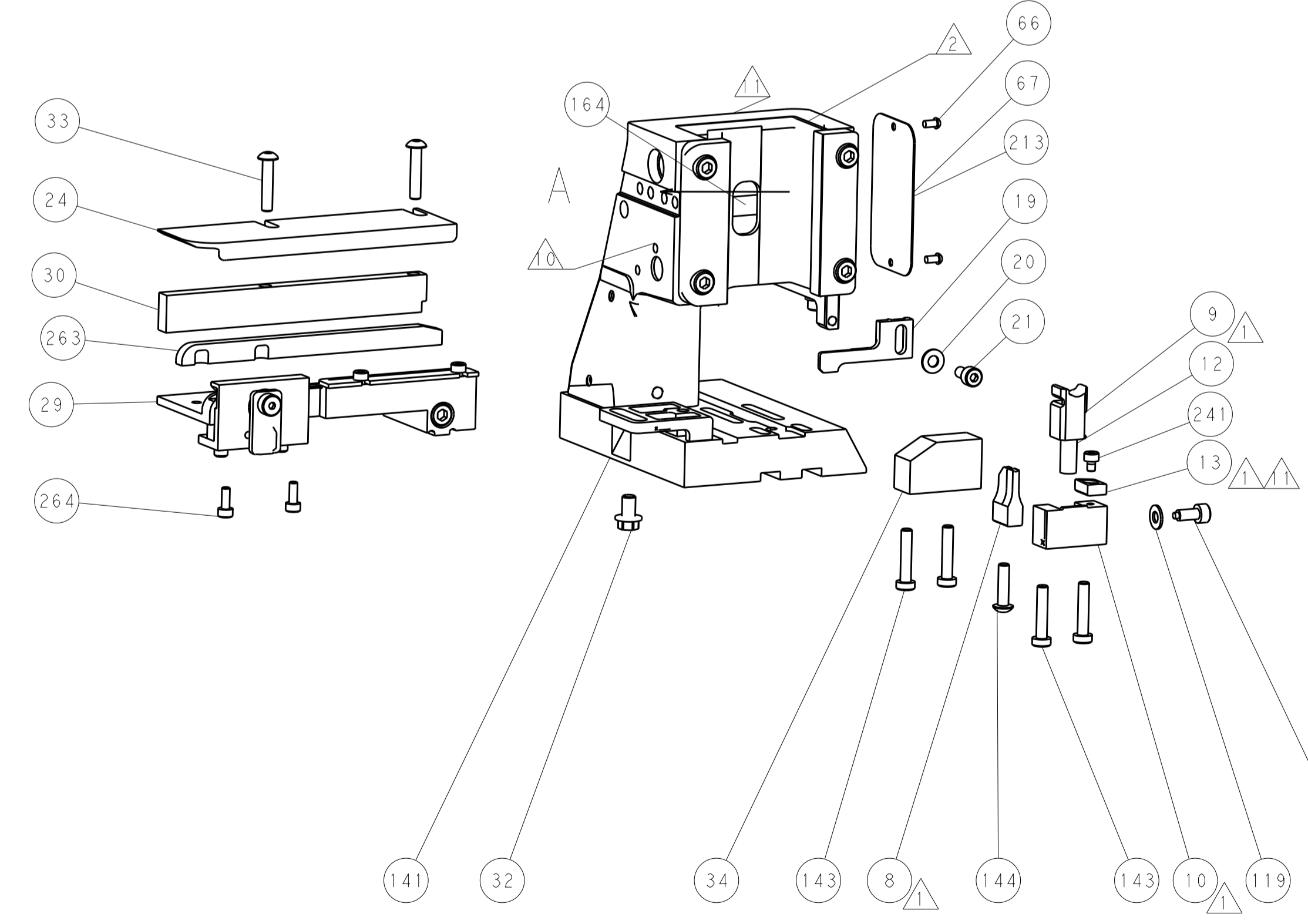
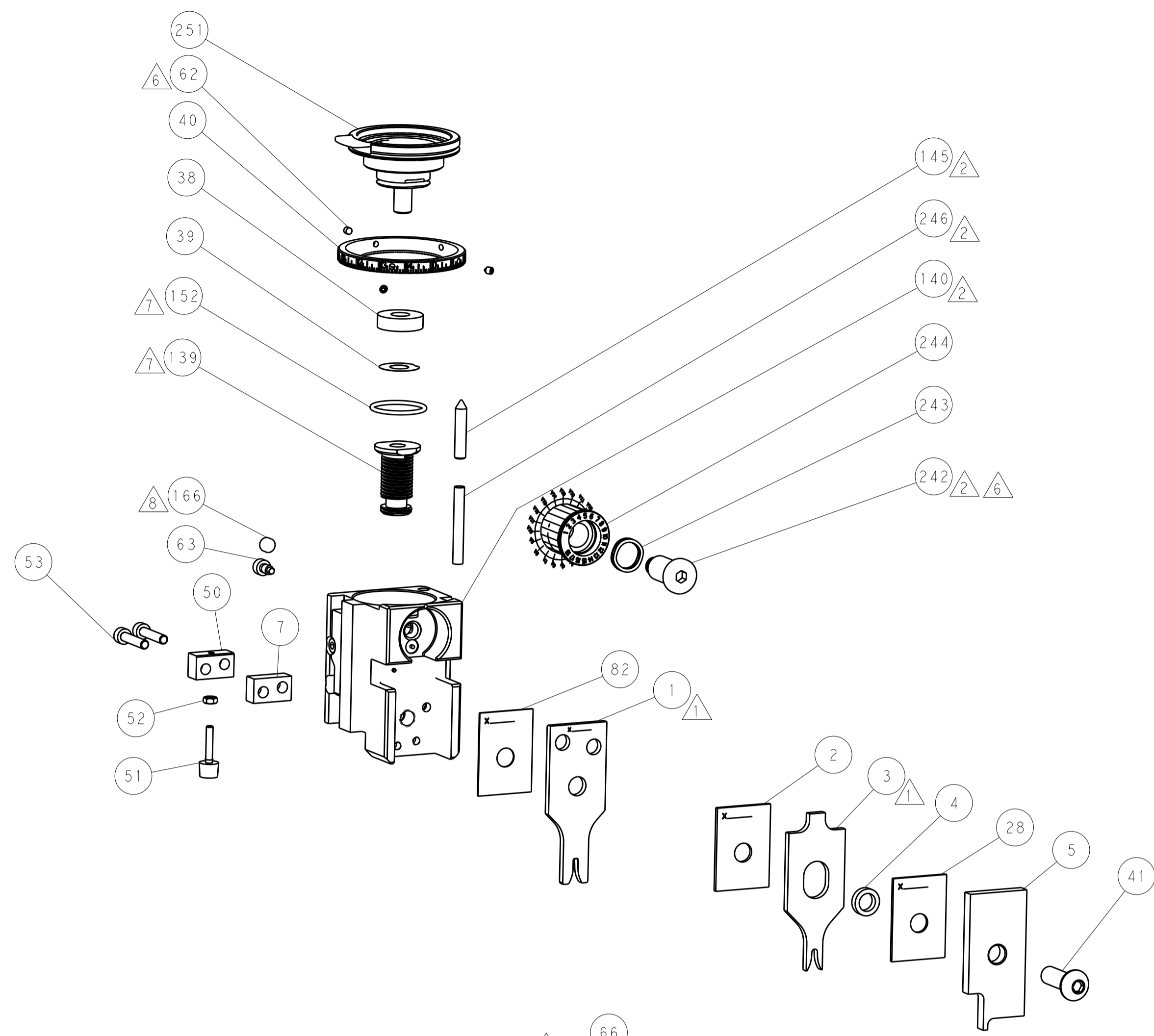
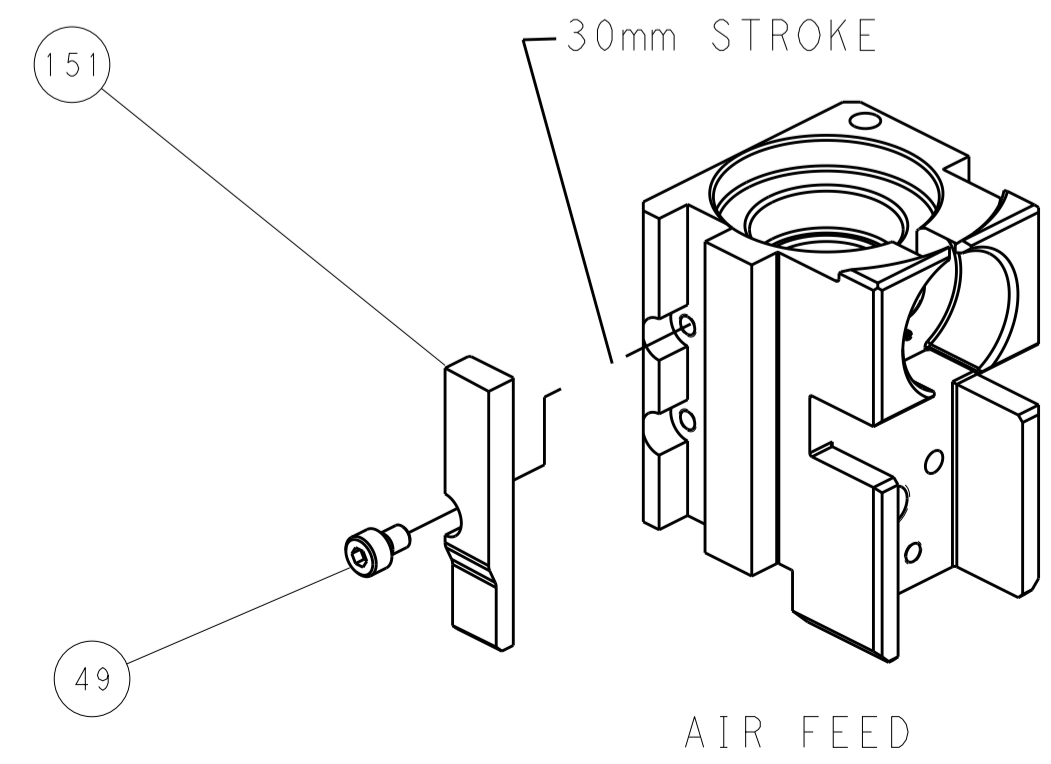

PACIFIC VERSION
 Shown on sheets 3 of 4 & 4 of 4
 (Atlantic version shown on sheets 1 of 4 & 2 of 4)

<small>THE DRAWING IS UNPUBLISHED. IT IS THE PROPERTY OF TYCO ELECTRONICS CORPORATION. IT IS SUBJECT TO CHANGE AND WITHOUT WARRANTY OF MERCHANTABILITY. SHOULD BE CONTACTED FOR THE LATEST REVISION.</small>		DWN: C. CHEN 19JUN2012 CHK: S. XI 19JUN2012 APVD: J. CRUZ 19JUN2012	NAME: TE Connectivity Harrisburg, PA 17105-3608
DIMENSIONS: mm 	TOLERANCES UNLESS OTHERWISE SPECIFIED: 0 PLC ±.5 1 PLC ±0.5 2 PLC ±0.13 3 PLC ±0.013 4 PLC ±0.001 ANGLES ±.1	PRODUCT SPEC: APPLICATION SPEC:	SIZE: CAGE CODE: DRAWING NO: RESTRICTED TO:
MATERIAL:	FINISH:	WEIGHT: Customer Accessible Production Drawing	SCALE: 1:2 SHEET 4 OF 4 REV C