

Wet Tantalum SMD Capacitors, Tantalum Metal Case with Glass-to-Tantalum Hermetic Seal, DLA Approved

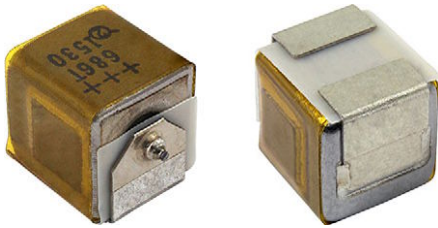

FEATURES

- Enhanced performance, high reliability design
- SMD, standard tin / lead (Sn / Pb)
- Mounting: surface-mount
- Increased thermal shock capability of 300 cycles
- Designed for the avionics and aerospace applications

PERFORMANCE CHARACTERISTICS

Operating Temperature: -55 °C to +85 °C
(to +125 °C with voltage derating)

DC Leakage Current (DCL Max.): at +25 °C and above: leakage current shall not exceed the values listed in the Standard Ratings table.

Capacitance Range: 10 µF to 68 µF

Capacitance Tolerance: ± 10 %, ± 20 % standard

Voltage Rating: 50 V_{DC} to 125 V_{DC}

ORDERING INFORMATION				
19001	-01	K	S	/HR
DLA DRAWING NUMBER	DASH NUMBER	CAPACITANCE TOLERANCE	VIBRATION OPTION	PACKAGING
		K = ± 10 % M = ± 20 %	S = standard	Blank = full 7" reel /HR = half 7" reel /PR = partial 7" reel

DIMENSIONS in inches [millimeters]						
CASE CODE	L (MAX.)	L1	W	H	P	Tw
C	0.354 [9.0]	0.303 ± 0.008 [7.7 ± 0.2]	0.279 ± 0.008 [7.1 ± 0.2]	0.291 ± 0.008 [7.4 ± 0.2]	0.098 ± 0.008 [2.5 ± 0.2]	0.197 ± 0.008 [5.0 ± 0.2]

Notes

- Dimensions are in inches
- Metric equivalents are given in parentheses for general information only
- These capacitors are designed for mounting by reflow soldering, or other conventional means

MARKING													
	<table border="1"> <thead> <tr> <th colspan="2">VOLTAGE CODE</th> </tr> <tr> <th>V</th> <th>CODE</th> </tr> </thead> <tbody> <tr> <td>50</td> <td>T</td> </tr> <tr> <td>75</td> <td>S</td> </tr> <tr> <td>100</td> <td>R</td> </tr> <tr> <td>125</td> <td>B</td> </tr> </tbody> </table>	VOLTAGE CODE		V	CODE	50	T	75	S	100	R	125	B
	VOLTAGE CODE												
	V	CODE											
	50	T											
	75	S											
100	R												
125	B												

STANDARD RATINGS											
CAPACITANCE AT +25 °C 120 Hz (μ F)	CASE CODE	PART NUMBER	MAX. ESR AT +25 °C 120 Hz (Ω)	MAX. IMP. AT -55 °C 120 Hz (Ω)	MAX. DCL (μ A) AT		MAX. CAPACITANCE CHANGE (%)			AC RIPPLE +85 °C 40 kHz (mA _{RMS})	
					+25 °C	+85 °C AND +125 °C	-55 °C	+85 °C	+125 °C		
50 V_{DC} AT +85 °C; 30 V_{DC} AT +125 °C; SURGE (+85 °C) 57.5 V_{DC}											
68	C	19001-04(1)S(2)	1.5	35	1.0	5.0	-25	+8	+15	1650	
75 V_{DC} AT +85 °C; 50 V_{DC} AT +125 °C; SURGE (+85 °C) 86.3 V_{DC}											
33	C	19001-12(1)S(2)	2.5	66	1.0	5.0	-25	+5	+9	1310	
100 V_{DC} AT +85 °C; 65 V_{DC} AT +125 °C; SURGE (+85 °C) 115 V_{DC}											
15	C	19001-16(1)S(2)	3.5	125	1.0	5.0	-18	+3	+10	1030	
125 V_{DC} AT +85 °C; 85 V_{DC} AT +125 °C; SURGE (+85 °C) 144 V_{DC}											
10	C	19001-20(1)S(2)	5.5	175	1.0	5.0	-15	+3	+10	832	

Note

- Part number definitions:
 - Capacitance tolerance: K = 10 %, M = 20 %
 - Packaging: blank, /HR, /PR

POWER DISSIPATION	
CASE CODE	MAXIMUM PERMISSIBLE POWER DISSIPATION AT +25 °C (W) IN FREE AIR
C	0.9

STANDARD PACKAGING QUANTITY			
CASE CODE	UNITS PER REEL		
	7" FULL REEL	7" HALF REEL	7" PARTIAL REEL
C	100	50	25

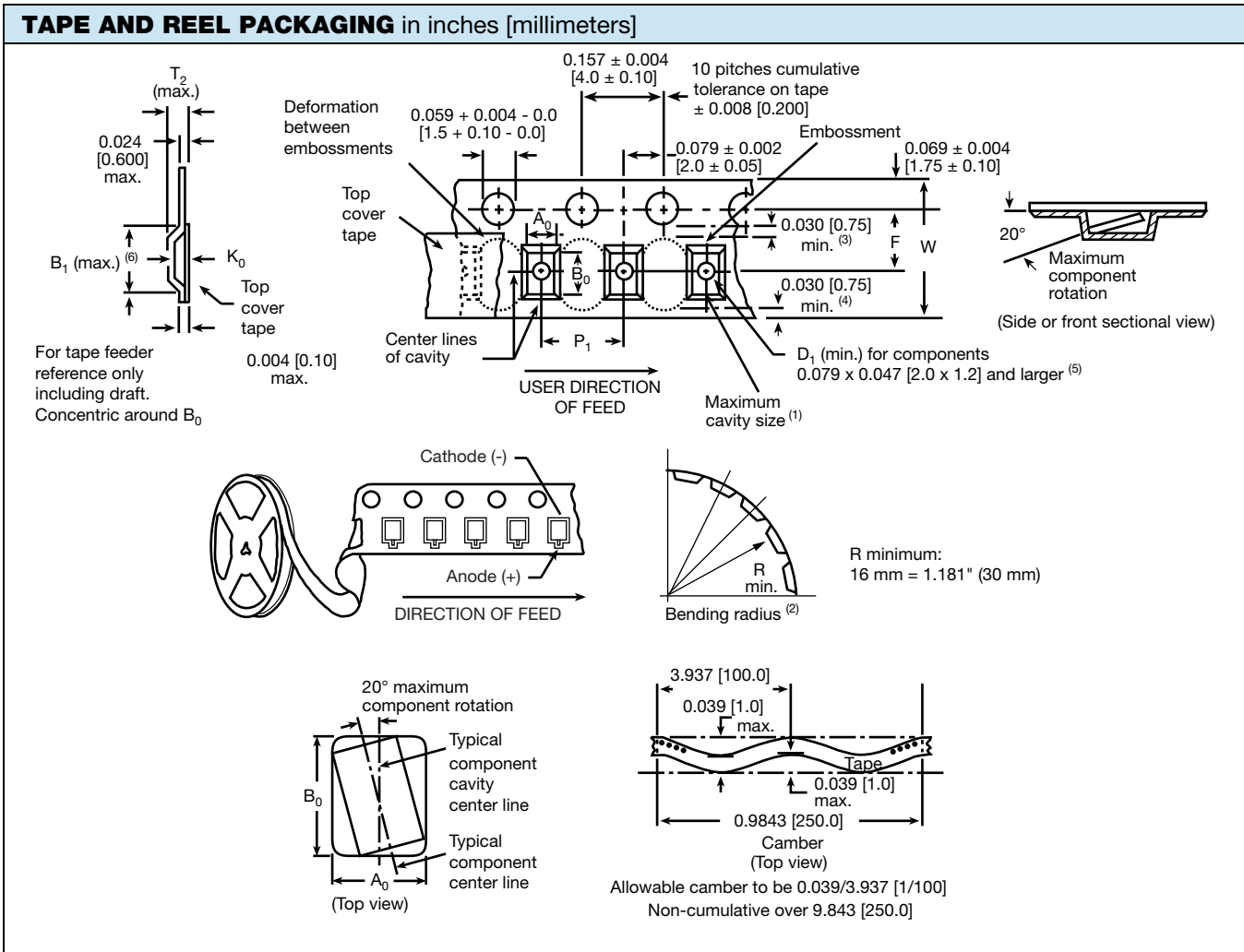

Notes

- Metric dimensions will govern. Dimensions in inches are rounded and for reference only
- (1) A_0 , B_0 , K_0 , are determined by the maximum dimensions to the ends of the terminals extending from the component body and / or the body dimensions of the component. The clearance between the ends of the terminals or body of the component to the sides and depth of the cavity (A_0 , B_0 , K_0) must be within 0.002" (0.05 mm) minimum and 0.020" (0.50 mm) maximum. The clearance allowed must also prevent rotation of the component within the cavity of not more than 20°
- (2) Tape with components shall pass around radius "R" without damage. The minimum trailer length may require additional length to provide "R" minimum for 12 mm embossed tape for reels with hub diameters approaching N minimum
- (3) This dimension is the flat area from the edge of the sprocket hole to either outward deformation of the carrier tape between the embossed cavities or to the edge of the cavity whichever is less
- (4) This dimension is the flat area from the edge of the carrier tape opposite the sprocket holes to either the outward deformation of the carrier tape between the embossed cavity or to the edge of the cavity whichever is less
- (5) The embossed hole location shall be measured from the sprocket hole controlling the location of the embossment. Dimensions of embossment location shall be applied independent of each other
- (6) B_1 dimension is a reference dimension tape feeder clearance only

CARRIER TAPE DIMENSIONS in inches [millimeters]					
TAPE WIDTH	W	P_2	F	E_1	E_2 MIN.
16 mm	$0.630 + 0.012 / - 0.004$ [16.0 + 0.3 / - 0.1]	0.079 ± 0.004 [2.0 ± 0.1]	0.295 ± 0.004 [7.5 ± 0.1]	0.069 ± 0.004 [1.75 ± 0.1]	0.561 [14.25]

CARRIER TAPE DIMENSIONS in inches [millimeters]					
TYPE	CASE CODE	TAPE WIDTH W (mm)	P ₁	K ₀ MAX.	B ₁ MAX.
DLA 19001	C	16	0.476 ± 0.004 [12.0 ± 0.1]	0.31 [7.9]	0.45 [11.3]

RECOMMENDED REFLOW PROFILES

Capacitors should withstand reflow profile as per J-STD-020 standard

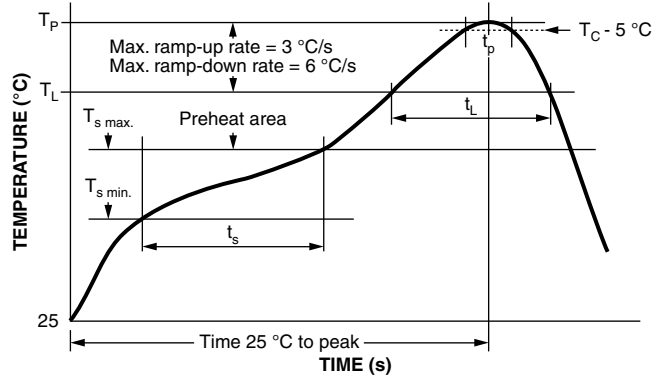

PROFILE FEATURE	SnPb EUTECTIC ASSEMBLY	LEAD (Pb)-FREE ASSEMBLY
Preheat / soak		
Temperature min. (T _{s min.})	100 °C	150 °C
Temperature max. (T _{s max.})	150 °C	200 °C
Time (t _s) from (T _{s min.} to T _{s max.})	60 s to 120 s	60 s to 120 s
Ramp-up		
Ramp-up rate (T _L to T _P)	3 °C/s max.	3 °C/s max.
Liquidus temperature (T _L)	183 °C	217 °C
Time (t _L) maintained above T _L	60 s to 150 s	60 s to 150 s
Peak package body temperature (T _P)	220	245
Time (t _p) within 5 °C of the specified classification temperature (T _C)	20 s	30 s
Time 25 °C to peak temperature	6 min max.	8 min max.
Ramp-down		
Ramp-down rate (T _P to T _L)	6 °C/s max.	6 °C/s max.
Time 25 °C to peak temperature	6 min max.	8 min max.

PAD DIMENSIONS in inches [millimeters]

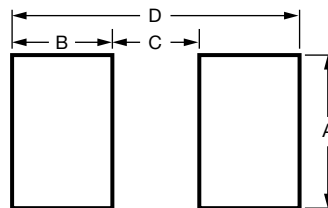

CASE CODE	A (MIN.)	B (NOM.)	C (NOM.)	D (NOM.)
C	0.295 [7.50]	0.138 [3.50]	0.100 [2.50]	0.374 [9.50]



RIPPLE CURRENT MULTIPLIERS VS. FREQUENCY, TEMPERATURE AND APPLIES PEAK VOLTAGE																									
FREQUENCY OF APPLIED RIPPLE CURRENT		120 Hz				800 Hz				1 kHz				10 kHz				40 kHz				100 kHz			
AMBIENT STILL AIR TEMP. IN °C		≤ 55	85	105	125	≤ 55	85	105	125	≤ 55	85	105	125	≤ 55	85	105	125	≤ 55	85	105	125	≤ 55	85	105	125
% of 85 °C rated peak voltage	100 %	0.60	0.39	-	-	0.71	0.43	-	-	0.72	0.46	-	-	0.88	0.55	-	-	1.0	0.63	-	-	1.1	0.69	-	-
	90 %	0.60	0.46	-	-	0.71	0.55	-	-	0.72	0.55	-	-	0.88	0.67	-	-	1.0	0.77	-	-	1.1	0.85	-	-
	80 %	0.60	0.52	0.35	-	0.71	0.62	0.42	-	0.72	0.62	0.42	-	0.88	0.76	0.52	-	1.0	0.87	0.59	-	1.1	0.96	0.65	-
	70 %	0.60	0.58	0.44	-	0.71	0.69	0.52	-	0.72	0.70	0.52	-	0.88	0.85	0.64	-	1.0	0.97	0.73	-	1.1	1.07	0.80	-
	66 2/3 %	0.60	0.60	0.46	0.27	0.71	0.71	0.55	0.32	0.72	0.72	0.55	0.32	0.88	0.88	0.68	0.40	1.0	1.0	0.77	0.45	1.1	1.1	0.85	0.50

TYPICAL PERFORMANCE CHARACTERISTICS OF DLA 19001 CAPACITORS

ELECTRICAL PERFORMANCE CHARACTERISTICS			
ITEM	PERFORMANCE CHARACTERISTICS		
Category temperature range	-55 °C to +85 °C (to +125 °C with voltage derating)		
Capacitance tolerance	± 20 %, ± 10 % at +25 °C, 120 Hz		
Capacitance change by temperature	Limit per Standard Ratings table		
ESR	Limit per Standard Ratings table, at +25 °C, 120 Hz		
Impedance	Limit per Standard Ratings table, at -55 °C, 120 Hz		
DCL (leakage current)	Limit per Standard Ratings table		
AC ripple current	Limit per Standard Ratings table, at +85 °C and 40 kHz		
Reverse voltage	Reverse voltage shall be in accordance with MIL-PRF-39006, paragraphs 3.23 and 4.8.19		
Maximum operating voltage	OPERATING TEMPERATURE		
	+85 °C		
	RATED VOLTAGE (V_{DC})	SURGE VOLTAGE (V_{DC})	DERATED VOLTAGE (V_{DC})
	50	57.5	30
	60	69.0	40
	75	86.3	50
	100	115.0	65
	125	144.0	85
Surge voltage	The DC rated surge voltage is the maximum voltage to which the capacitors can be subjected under any conditions including transients and peak ripple at the highest line voltage. The DC surge voltage is 115 % of rated DC voltage		

PERFORMANCE CHARACTERISTICS	
ITEM	PERFORMANCE CHARACTERISTICS
Life testing	Capacitors shall be capable of withstanding a 2000 hour life test at +85°C at rated voltage. After the test, the capacitors shall meet the following requirements: a. DC leakage at +85 °C shall not exceed 125 % of the specified value b. DC leakage at +25 °C shall not exceed the specified value c. Capacitance shall be within +10 %, -20 % of initial value d. ESR shall not exceed 200 % of the specified value e. Dielectric withstanding voltage: in accordance with MIL-PRF-39006 f. Insulation resistance: in accordance with MIL-PRF-39006 g. Visual examination: shall show no damage, obliteration of marking, or leakage of electrolyte
Surge voltage	Surge voltage shall be in accordance with MIL-PRF-39006 and DLA 19001, except capacitance shall change not more than +5 %, -20 % of the initial measured value.
AC ripple life	In accordance with MIL-PRF-39006: 2000 h, +85 °C



ENVIRONMENTAL CHARACTERISTICS			
ITEM	CONDITION	POST TEST PERFORMANCE	
Seal	MIL-PRF-39006	When the capacitors are tested as specified in MIL-PRF-39006, there shall be no evidence of leakage.	
Moisture resistance	MIL-STD-202-106 Number of cycles: 10 continuous cycles except that steps 7a and 7b shall be omitted.	DC leakage	Not exceed 125 % of the specified value
		Capacitance change	Within ± 10 % of the initial measured value
		ESR	Not exceed the specified value
Stability at low and high temperatures	MIL-PRF-39006	The capacitors shall meet the requirements of MIL-PRF-39006	
Barometric pressure (reduced)	MIL-PRF-39006	Barometric pressure shall be in accordance with MIL-PRF-39006. There shall be no mechanical or visual damage to capacitors post-conditioning.	

MECHANICAL PERFORMANCE CHARACTERISTICS		
ITEM	CONDITION	POST TEST PERFORMANCE
Solderability	MIL-STD-202-208, test B	All terminations shall exhibit a continuous solder coating free from defects for a minimum of 95 % of the critical area of any individual lead.
Shock (specified pulse)	MIL-STD-202-213, condition D (500 g peak)	The capacitors shall meet the requirements of MIL-PRF-39006.
Vibration, high frequency	MIL-STD-202-204, condition H (80 g peak)	The capacitors shall meet the requirements of MIL-PRF-39006.
Random vibration	MIL-STD-202-214, condition II-G (overall RMS 27.78 G)	The capacitors shall meet the requirements of MIL-PRF-39006.
Thermal shock	MIL-PRF-39006	Thermal shock shall be in accordance with MIL-PRF-39006 when tested for 300 cycles.
Resistance to solvents	MIL-STD-202-215	There shall be no mechanical or visual damage to capacitors post-conditioning. Marking shall remain legible and shall not smear (no degradation of the can material).
Resistance to soldering heat	MIL-STD-202-210, test condition J, except with only one heat cycle	The capacitors shall meet the requirements of MIL-PRF-39006. The combination of the mounting process and 1 heat cycle is effectively equivalent to 2 heat cycles. There shall be no mechanical or visual damage to capacitors.

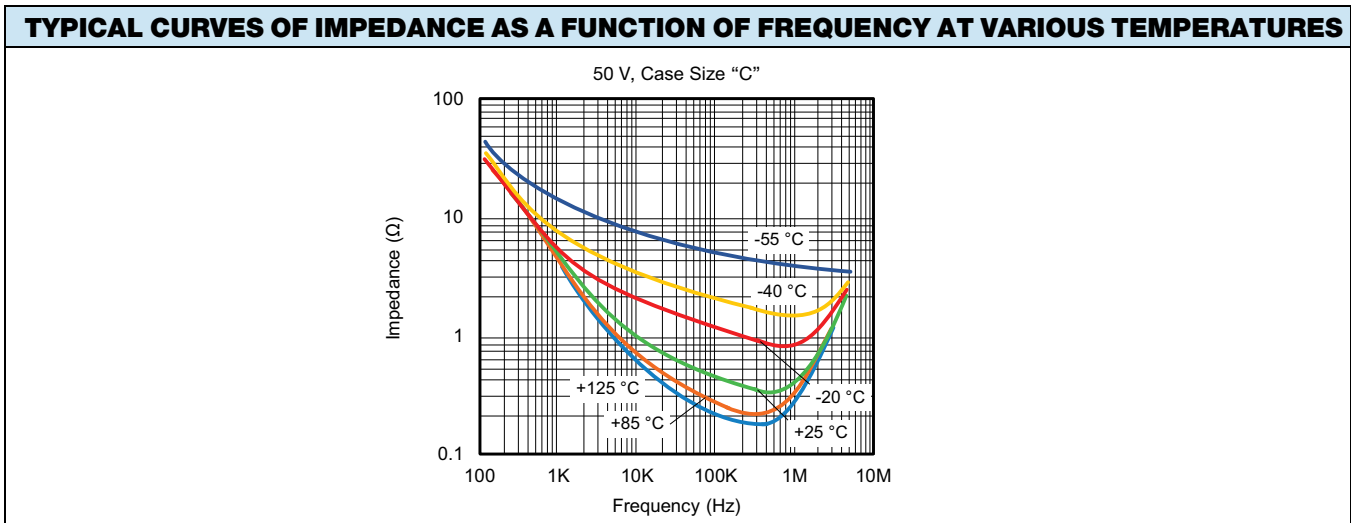



Disclaimer

ALL PRODUCT, PRODUCT SPECIFICATIONS AND DATA ARE SUBJECT TO CHANGE WITHOUT NOTICE TO IMPROVE RELIABILITY, FUNCTION OR DESIGN OR OTHERWISE.

Vishay Intertechnology, Inc., its affiliates, agents, and employees, and all persons acting on its or their behalf (collectively, "Vishay"), disclaim any and all liability for any errors, inaccuracies or incompleteness contained in any datasheet or in any other disclosure relating to any product.

Vishay makes no warranty, representation or guarantee regarding the suitability of the products for any particular purpose or the continuing production of any product. To the maximum extent permitted by applicable law, Vishay disclaims (i) any and all liability arising out of the application or use of any product, (ii) any and all liability, including without limitation special, consequential or incidental damages, and (iii) any and all implied warranties, including warranties of fitness for particular purpose, non-infringement and merchantability.

Statements regarding the suitability of products for certain types of applications are based on Vishay's knowledge of typical requirements that are often placed on Vishay products in generic applications. Such statements are not binding statements about the suitability of products for a particular application. It is the customer's responsibility to validate that a particular product with the properties described in the product specification is suitable for use in a particular application. Parameters provided in datasheets and / or specifications may vary in different applications and performance may vary over time. All operating parameters, including typical parameters, must be validated for each customer application by the customer's technical experts. Product specifications do not expand or otherwise modify Vishay's terms and conditions of purchase, including but not limited to the warranty expressed therein.

Except as expressly indicated in writing, Vishay products are not designed for use in medical, life-saving, or life-sustaining applications or for any other application in which the failure of the Vishay product could result in personal injury or death. Customers using or selling Vishay products not expressly indicated for use in such applications do so at their own risk. Please contact authorized Vishay personnel to obtain written terms and conditions regarding products designed for such applications.

No license, express or implied, by estoppel or otherwise, to any intellectual property rights is granted by this document or by any conduct of Vishay. Product names and markings noted herein may be trademarks of their respective owners.