

Verpackt in Gurtverpackung - *Tape on Reel Packaging*
 Verpackungseinheit: 300 Stück - *Packaging unit: 300 pcs*

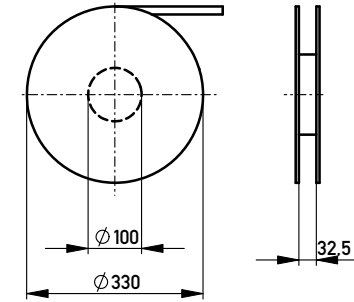

Abspulrichtung - *Reel off Direction* →

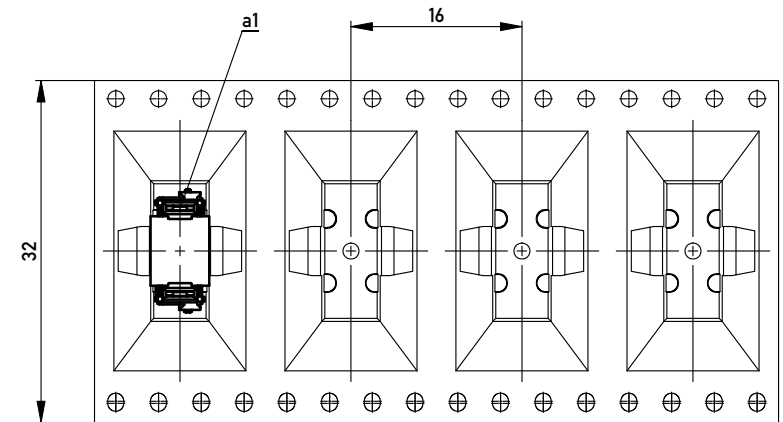
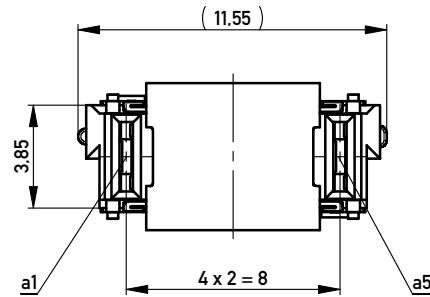

Leiterplatten-Layout Vorschlag / *PCB-layout proposal*

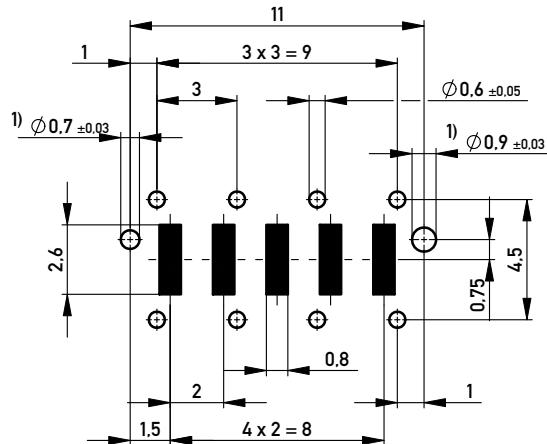

1) Durchmesser des Bohrers / *Drill tool*

Anforderungsstufe 1
Performance Level 1

Kontaktbereich vergoldet
Mating Area gold plating

Anschlussbereich verzinkt 4-6µm
Terminal Area 4-6µm tin plating

Koplanarität der Anschlüsse ≤ 0.1mm
Coplanarity Area of Termination ≤ 0.1mm

Information: All rights reserved. Only for Information. To ensure that this is the latest version of this drawing, please contact one of the ERNI companies before using.	Tolerances All Dimensions in mm	Scale 5:1	
		Designation Federleiste THR, Powerm. 8mm <i>Fedmale Con. THR, Powerm. 8mm</i>	
f Index	11.08.2010 Date	www.ERNI.com	214914 I A3
Class		MSPEED	

Copyright by ERNI GmbH
 Proprietary notice pursuant to ISO 16106 to be observed.