

THIS DRAWING IS UNPUBLISHED. RELEASED FOR PUBLICATION 20  
 © COPYRIGHT 20 BY - ALL RIGHTS RESERVED.

LOC		DIST		REVISIONS			
P	LTR	DESCRIPTION	DATE	DWN	APVD		
CM	00						
	AI	REVISED PER ECR-12-007353	18MAY2012	KH	TM		

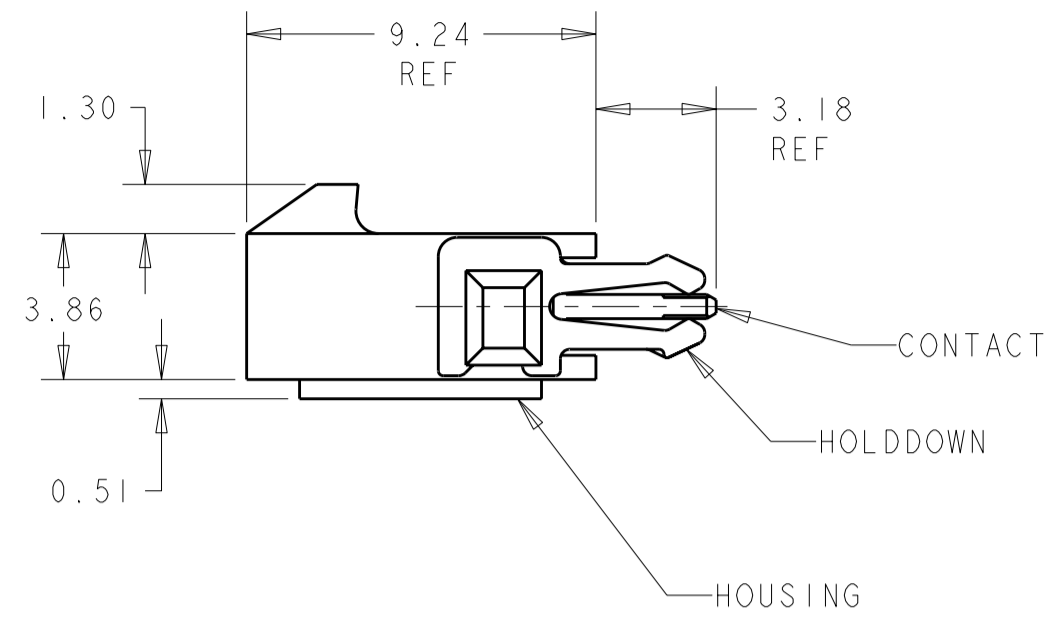

- 1 MATERIAL: CONTACTS - BRASS  
HOUSING - UL 94V-0 RATED HIGH TEMP NYLON, COLOR BLACK.  
HOLDDOWNS: - PHOSPHOR BRONZE.
- 2 PLATING: CONTACTS - 0.38µm MINIMUM GOLD ON MATING END,  
2.54µm MINIMUM TIN LEAD ON SOLDER TAILS, BOTH OVER  
1.27µm MINIMUM NICKEL.  
HOLDDOWNS: 2.54µm MINIMUM TIN-LEAD OVER 1.27µm MINIMUM  
NICKEL.
- 4 RECOMMENDED PC BOARD THICKNESS OF 1.57.
- 5 PLATING: CONTACTS - 0.38µm MINIMUM GOLD ON MATING END,  
2.54µm MINIMUM MATTE TIN ON SOLDER TAILS, BOTH OVER  
1.27µm MINIMUM NICKEL.  
HOLDDOWNS: 2.54µm MINIMUM MATTE TIN OVER 1.27µm MINIMUM  
NICKEL.

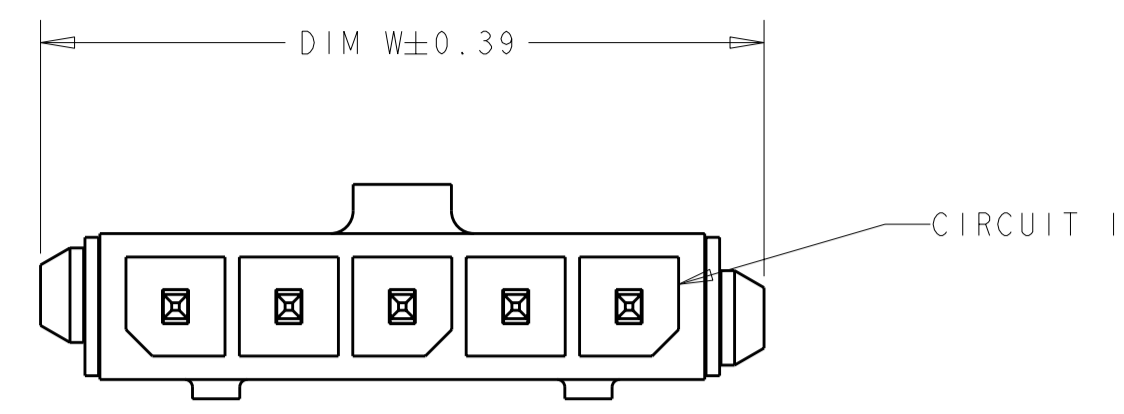
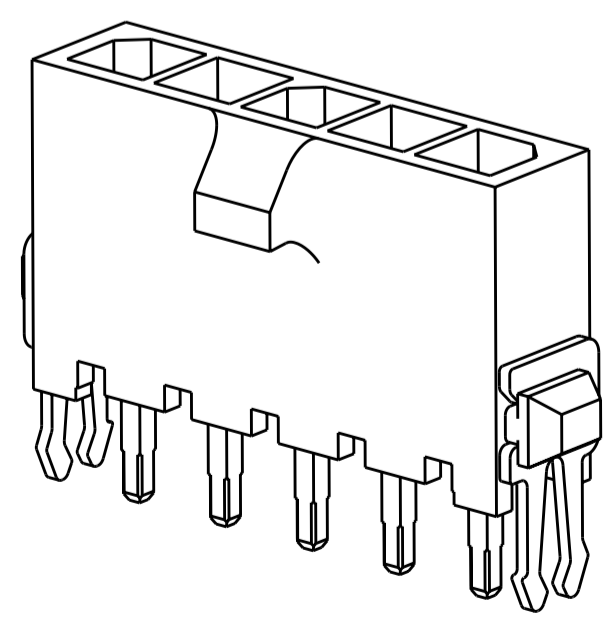
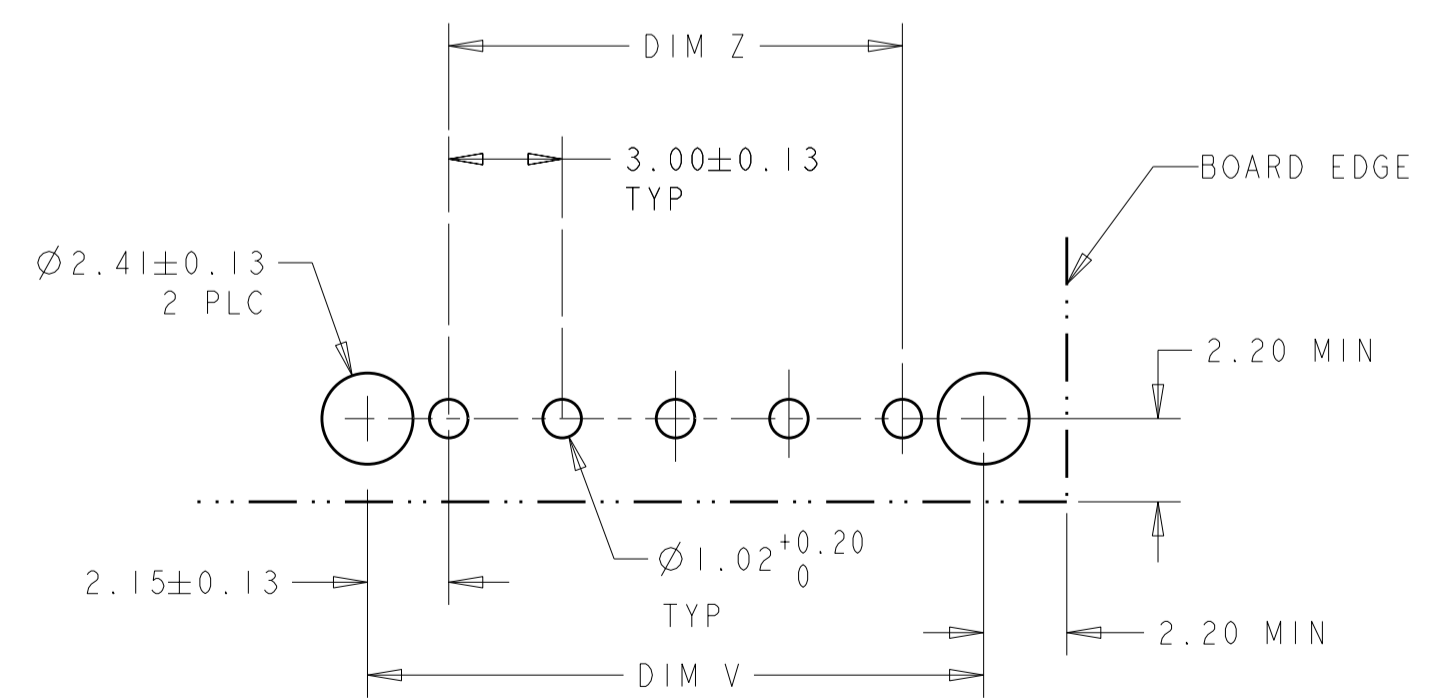
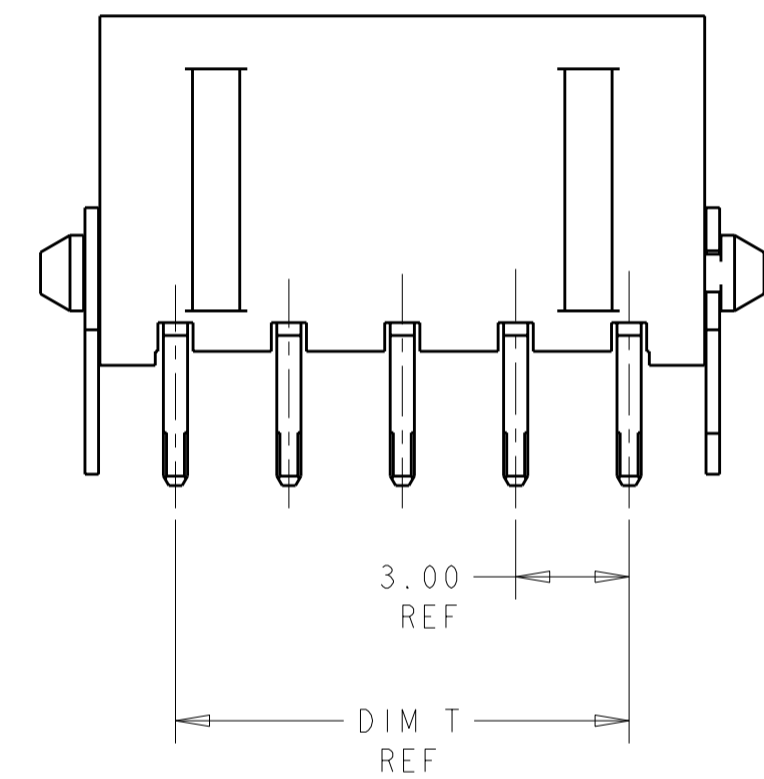

5	33.00	37.43	33.00	40.14	12	3-1445085-2
5	30.00	34.43	30.00	37.14	11	3-1445085-1
5	27.00	31.43	27.00	34.14	10	3-1445085-0
5	24.00	28.43	24.00	31.14	9	2-1445085-9
5	21.00	25.43	21.00	28.14	8	2-1445085-8
5	18.00	22.43	18.00	25.14	7	2-1445085-7
5	15.00	19.43	15.00	22.14	6	2-1445085-6
5	12.00	16.43	12.00	19.14	5	2-1445085-5
5	9.00	13.43	9.00	16.14	4	2-1445085-4
5	6.00	10.43	6.00	13.14	3	2-1445085-3
5	3.00	7.43	3.00	10.14	2	2-1445085-2
2	33.00	37.43	33.00	40.14	12	1-1445085-2
2	30.00	34.43	30.00	37.14	11	1-1445085-1
2	27.00	31.43	27.00	34.14	10	1-1445085-0
2	24.00	28.43	24.00	31.14	9	1445085-9
2	21.00	25.43	21.00	28.14	8	1445085-8
2	18.00	22.43	18.00	25.14	7	1445085-7
2	15.00	19.43	15.00	22.14	6	1445085-6
2	12.00	16.43	12.00	19.14	5	1445085-5
2	9.00	13.43	9.00	16.14	4	1445085-4
2	6.00	10.43	6.00	13.14	3	1445085-3
2	3.00	7.43	3.00	10.14	2	1445085-2
FINISH	DIM Z	DIM V	DIM T	DIM W	NO. OF POSN	PART NUMBER

PCB LAYOUT COMPONENT SIDE



THIS DRAWING IS A CONTROLLED DOCUMENT. DWN J.ROOT 10OCT2000  
 CHK K. WHITAKER 17-APR-2001  
 APVD C. JONES 17-APR-2001

**STE** TE Connectivity

NAME VERTICAL THRU HOLE HEADER ASSY,  
 0.38 MIC GOLD CONTACTS W/THRU HOLE  
 HOLDDOWNS, SGL ROW, MICRO MATE-N-LOK™

SIZE A2 CAGE CODE 00779 DRAWING NO. 1445085 RESTRICTED TO

MATERIAL SEE TABLE

PRODUCT SPEC -  
 APPLICATION SPEC -  
 WEIGHT -

CUSTOMER DRAWING SCALE 5:1 SHEET 1 OF 1 REV AI