

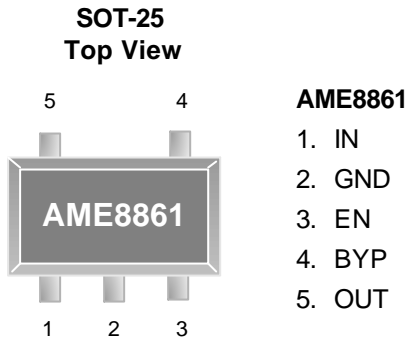
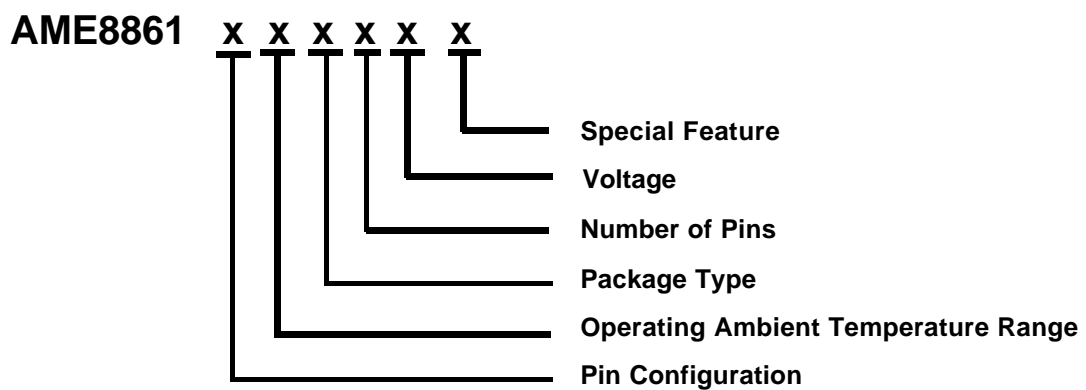

**■ Pin Configuration**

**\* Die Attach:**  
Conductive Epoxy

**■ Ordering Information**

Pin Configuration	Operating Ambient Temperature Range	Package Type	Number of Pins	Output Voltage	Special Feature
A: 1. IN <small>(SOT-25)</small> 2. GND <small>(TSOT-25)</small> 3. EN 4. BYP 5. OUT	E: -40°C to +85°C	E: SOT-2X	V: 5	180: V=1.8V 250: V=2.5V 300: V=3.0V 330: V=3.3V	L: Low Profile Y: Lead Free & Low Profile Z: Lead Free

**■ Ordering Information (contd.)**

Part Number	Marking*	Output Voltage	Package	Operating Ambient Temperature Range
AME8861AEEV180Y	BFNww	1.8V	TSOT-25	- 40°C to + 85°C
AME8861AEEV180Z	BFNww	1.8V	SOT-25	- 40°C to + 85°C
AME8861AEEV250	AXCww	2.5V	SOT-25	- 40°C to + 85°C
AME8861AEEV250L	AXCww	2.5V	TSOT-25	- 40°C to + 85°C
AME8861AEEV250Y	AXCww	2.5V	TSOT-25	- 40°C to + 85°C
AME8861AEEV250Z	AXCww	2.5V	SOT-25	- 40°C to + 85°C
AME8861AEEV300	AWGww	3.0V	SOT-25	- 40°C to + 85°C
AME8861AEEV300L	AWGww	3.0V	TSOT-25	- 40°C to + 85°C
AME8861AEEV300Y	AWGww	3.0V	TSOT-25	- 40°C to + 85°C
AME8861AEEV300Z	AWGww	3.0V	SOT-25	- 40°C to + 85°C
AME8861AEEV330	AXBww	3.3V	SOT-25	- 40°C to + 85°C
AME8861AEEV330L	AXBww	3.3V	TSOT-25	- 40°C to + 85°C
AME8861AEEV330Y	AXBww	3.3V	TSOT-25	- 40°C to + 85°C
AME8861AEEV330Z	AXBww	3.3V	SOT-25	- 40°C to + 85°C

Note: ww represents the date code and pls refer to date Code Rule before Package Dimension.

\* A line on top of the first character represents lead free plating such as BFNww.

Please consult AME sales office or authorized Rep./Distributor for the availability of output voltage and package type.

**■ Absolute Maximum Ratings**

Parameter	Maximum	Unit
Input Voltage	8	V
Output Current	$P_D / (V_{IN} - V_O)$	A
Input, Output Voltage	GND - 0.3 to $V_{IN} + 0.3$	V
ESD Classification	B*	

Caution: Stress above the listed absolute maximum rating may cause permanent damage to the device.

\* HBM B:2000V~3999V

**■ Recommended Operating Conditions**

Parameter	Symbol	Rating	Unit
Ambient Temperature Range	$T_A$	- 40 to +85	°C
Junction Temperature Range	$T_J$	- 40 to +125	°C
Storage Temperature Range	$T_{STG}$	- 65 to +150	°C

**■ Thermal Information**

Parameter	Package	Die Attach	Symbol	Maximum	Unit
Thermal Resistance* ( Junction to Case)	SOT-25	Conductive Epoxy	$\theta_{JC}$	81	°C / W
Thermal Resistance ( Junction to Ambient)			$\theta_{JA}$	260	
Internal Power Dissipation			$P_D$	400	mW
Maximum Junction Temperature				150	°C
Solder Iron (10 Sec)**				350	°C

\* Measure  $\theta_{JC}$  on center of molding compound if IC has no tab.

\*\* MIL-STD-202G 210F

**■ Electrical Specifications**
 $T_A = 25^\circ\text{C}$  unless otherwise noted.

Parameter	Symbol	Test Condition	Min	Typ	Max	Units	
Input Voltage	$V_{IN}$		Note 1		7	V	
Output Voltage Accuracy	$V_O$	$I_O=1\text{mA}$	-1.5		1.5	%	
Dropout Voltage	$V_{DROPOUT}$	$I_O=600\text{mA}$ $V_O=V_{O(NOM)} - 2.0\%$	$1.3\text{V} < V_{O(NOM)} \leq 1.4\text{V}$	See chart	1900	mV	
			$1.4\text{V} < V_{O(NOM)} \leq 2.0\text{V}$		1400		
			$2.0\text{V} < V_{O(NOM)} \leq 2.8\text{V}$		800		
			$2.8\text{V} < V_{O(NOM)}$		600		
Output Current	$I_O$	$V_O > 1.2\text{V}$	600			mA	
Current Limit	$I_{LIM}$	$V_O > 1.2\text{V}$	600	800		mA	
Short Circuit Current	$I_{SC}$	$V_O < 0.8\text{V}$		300	600	mA	
Quiescent Current	$I_Q$	$I_O=0\text{mA}$		30	50	$\mu\text{A}$	
Ground Pin Current	$I_{GND}$	$I_O=1\text{mA}$ to 600mA		35		$\mu\text{A}$	
Line Regulation	$REG_{LINE}$	$I_O=1\text{mA}$ $V_{IN}=V_O+1$ to $V_O+2$	$1.3\text{V} \leq V_O \leq 1.4\text{V}$	-0.2		0.2	%
			$1.4\text{V} < V_O \leq 2.0\text{V}$	-0.15		0.15	
			$2.0\text{V} < V_O < 4.0\text{V}$	-0.1	0.02	0.1	
			$V_O \geq 4.0\text{V}$	-0.4	0.2	0.4	
Load Regulation	$REG_{LOAD}$	$I_O=1\text{mA}$ to 600mA		0.2	1	%	
Over Temperature Shutdown	OTS			150		$^\circ\text{C}$	
Over Temperature Hysteresis	OTH			30		$^\circ\text{C}$	
$V_O$ Temperature Coefficient	TC			30		ppm/ $^\circ\text{C}$	
Power Supply Rejection	PSRR	$I_O=100\text{mA}$ $C_O=2.2\mu\text{F}$ ceramic $C_{BYP}=0.01\mu\text{F}$	$f=1\text{kHz}$		75	dB	
			$f=10\text{kHz}$		55		
			$f=100\text{kHz}$		30		
Output Voltage Noise	eN	$f=10\text{Hz}$ to 100kHz $I_O=10\text{mA}$ , $C_{BYP}=0.01\mu\text{F}$			30	$\mu\text{V}_{rms}$	

**■ Electrical Specifications (contd.)**

Parameter	Symbol	Test Condition	Min	Typ	Max	Units
EN Input Threshold	$V_{EH}$	$V_{IN}=2.7V$ to $7V$	2.0		$V_{in}$	V
	$V_{EL}$	$V_{IN}=2.7V$ to $7V$	0		0.4	V
EN Input Bias Current	$I_{EH}$	$V_{EN}=V_{IN}$ , $V_{IN}=2.7V$ to $7V$			0.1	$\mu A$
	$I_{EL}$	$V_{EN}=0V$ , $V_{IN}=2.7V$ to $7V$			0.5	$\mu A$
Shutdown Supply Current	$I_{SD}$	$V_{IN}=5V$ , $V_O=0V$ , $V_{EN}<V_{EL}$		0.5	1	$\mu A$
PG Leakage Current	$I_{LC}$	$V_{PG}=7V$			1	$\mu A$

Note2: To prevent the Short Circuit Current protection feature from being prematurely activated, the input voltage must be applied before a current source load is applied.

## ■ Detailed Description

The AME8861 family of CMOS regulators contain a PMOS pass transistor, voltage reference, error amplifier, over-current protection, and thermal shutdown.

The P-channel pass transistor receives data from the error amplifier, over-current shutdown, and thermal protection circuits. During normal operation, the error amplifier compares the output voltage to a precision reference. Over-current and Thermal shutdown circuits become active when the junction temperature exceeds 150°C, or the current exceeds 600mA. During thermal shutdown, the output voltage remains low. Normal operation is restored when the junction temperature drops below 120°C.

The AME8861 switches from voltage mode to current mode when the load exceeds the rated output current. This prevents over-stress. The AME8861 also incorporates current foldback to reduce power dissipation when the output is short circuited. This feature becomes active when the output drops below 0.8 volts, and reduces the current flow by 65%. Full current is restored when the voltage exceeds 0.8 volts.

## ■ External Capacitors

The AME8861 is stable with an output capacitor to ground of 2.2 $\mu$ F or greater. Ceramic capacitors have the lowest ESR, and will offer the best AC performance. Conversely, Aluminum Electrolytic capacitors exhibit the highest ESR, resulting in the poorest AC response. Unfortunately, large value ceramic capacitors are comparatively expensive. One option is to parallel a 0.1 $\mu$ F ceramic capacitor with a 10 $\mu$ F Aluminum Electrolytic. The benefit is low ESR, high capacitance, and low overall cost.

A second capacitor is recommended between the input and ground to stabilize  $V_{in}$ . The input capacitor should be at least 0.1 $\mu$ F to have a beneficial effect.

A third capacitor can be connected between the BY-PASS pin and GND. This capacitor can be a low cost Polyester Film variety between the value of 0.001 ~ 0.01 $\mu$ F. A larger capacitor improves the AC ripple rejection, but also makes the output come up slowly. This "Soft" turn-on is desirable in some applications to limit turn-on surges.

All capacitors should be placed in close proximity to the pins. A "Quiet" ground termination is desirable. This can be achieved with a "Star" connection.

## ■ Enable

The Enable pin normally floats high. When actively, pulled low, the PMOS pass transistor shuts off, and all internal circuits are powered down. In this state, the quiescent current is less than 1 $\mu$ A. This pin behaves much like an electronic switch.

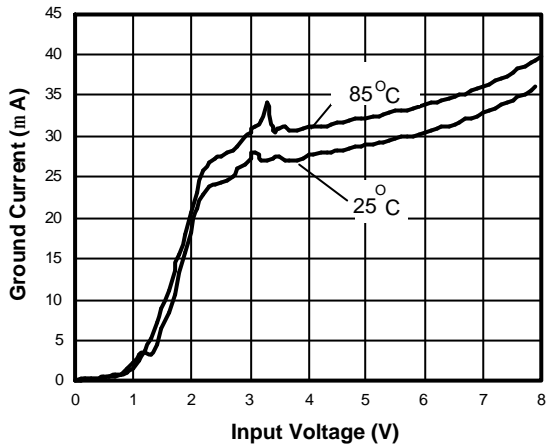
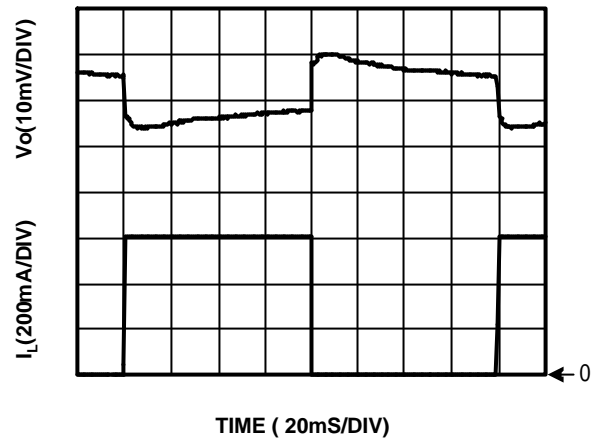
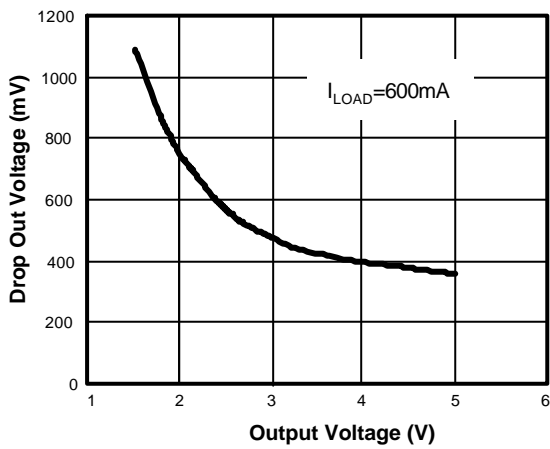
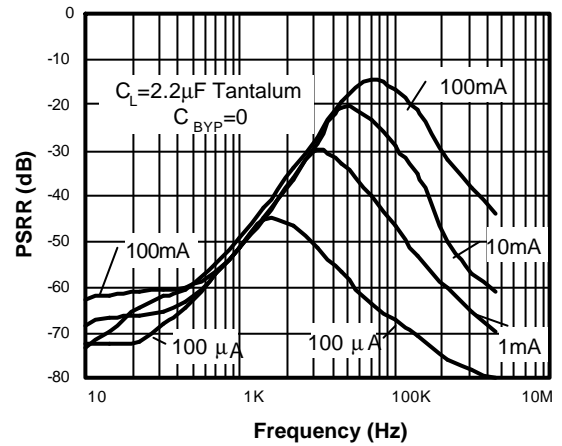
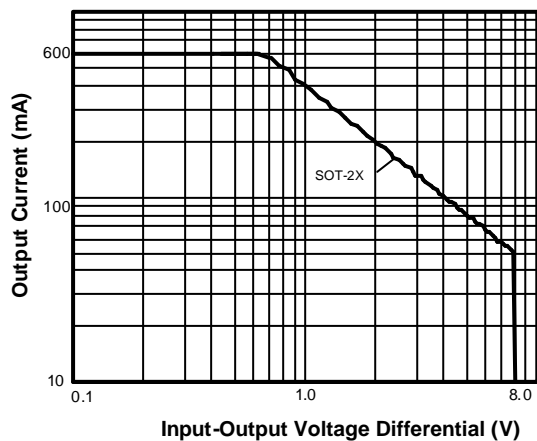
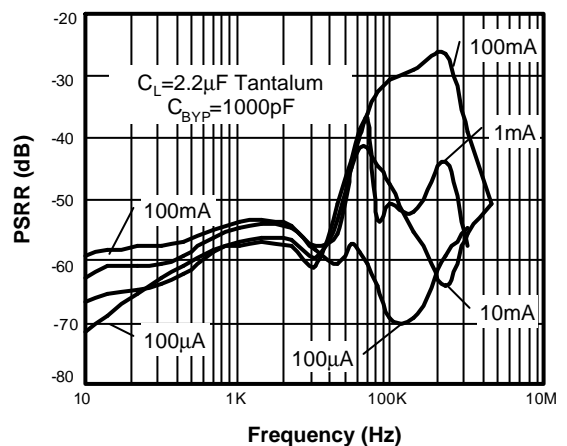
**■ Characterization Curve**
**Ground Current vs. Input Voltage**

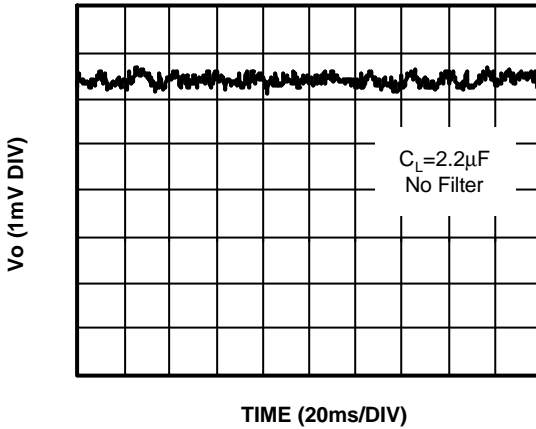
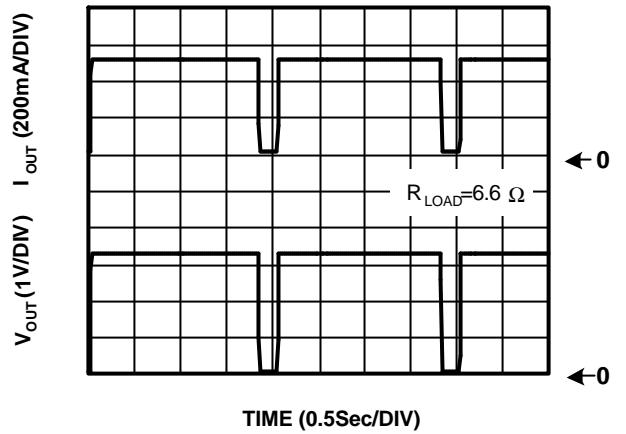
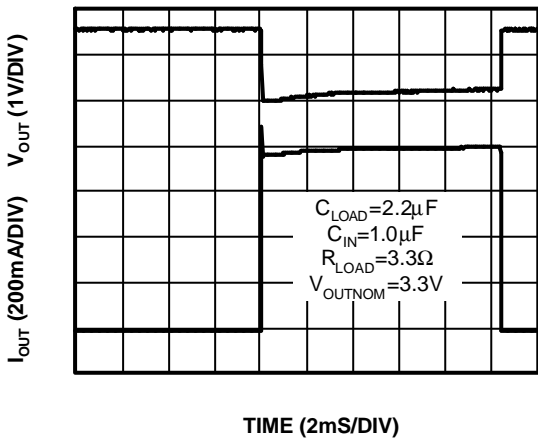
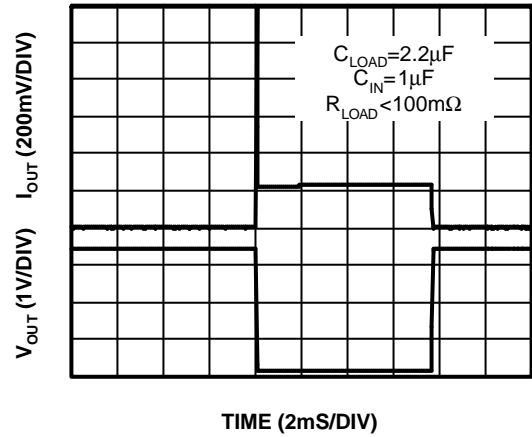
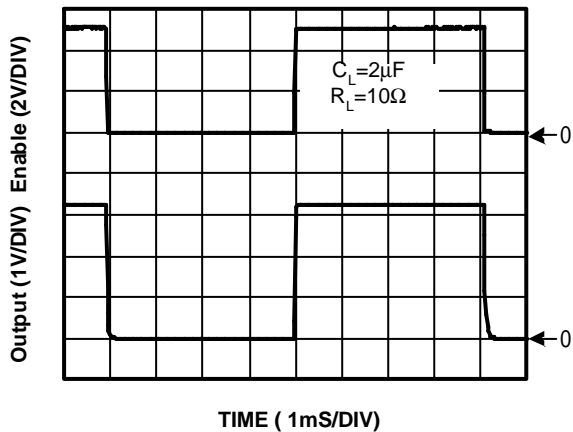
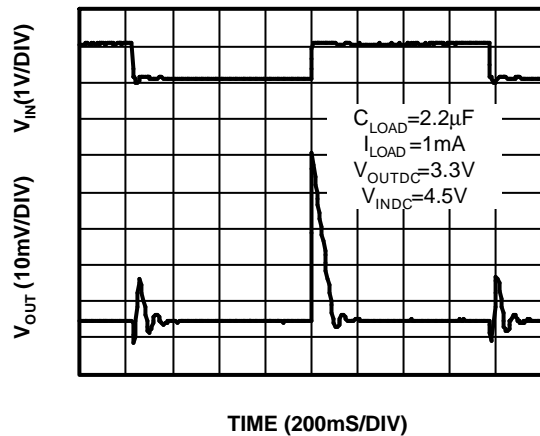
**Load Step (1mA-600mA)**

**Drop Out Voltage vs. Output Voltage**

**Power Supply Rejection Ratio**

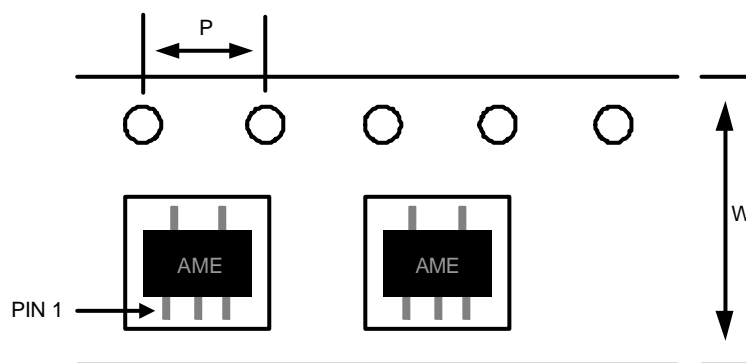
**Safe Operating Area**

**Power Supply Rejection Ratio**

**■ Characterization Curve**
**Noise Measurement**

**Overtemperature Shutdown**

**Current Limit Response**

**Short Circuit Response**

**Chip Enable Transient Response**

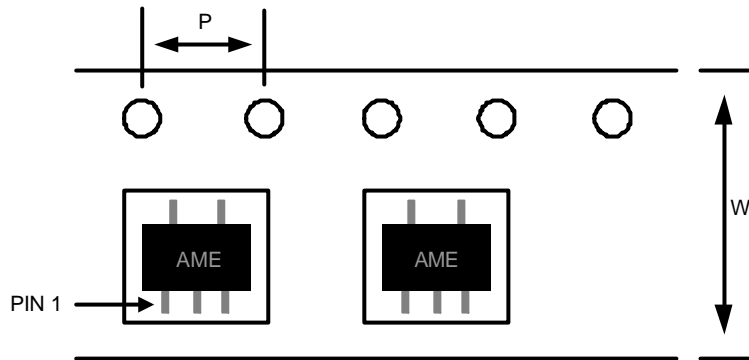
**Line Transient Response**

**■ Date Code Rule**

Marking			Date Code		Year
A	A	A	W	W	xxx0
A	A	A	W	<u>W</u>	xxx1
A	A	A	<u>W</u>	W	xxx2
A	A	A	<u>W</u>	<u>W</u>	xxx3
A	A	<u>A</u>	W	W	xxx4
A	A	<u>A</u>	W	<u>W</u>	xxx5
A	A	<u>A</u>	<u>W</u>	W	xxx6
A	A	<u>A</u>	<u>W</u>	<u>W</u>	xxx7
A	<u>A</u>	A	W	W	xxx8
A	<u>A</u>	A	W	<u>W</u>	xxx9

**■ Tape and Reel Dimension**
**SOT-25**

**Carrier Tape, Number of Components Per Reel and Reel Size**

Package	Carrier Width (W)	Pitch (P)	Part Per Full Reel	Reel Size
SOT-25	8.0±0.1 mm	4.0±0.1 mm	3000pcs	180±1 mm

**■ Tape and Reel Dimension**
**TSOT-25**

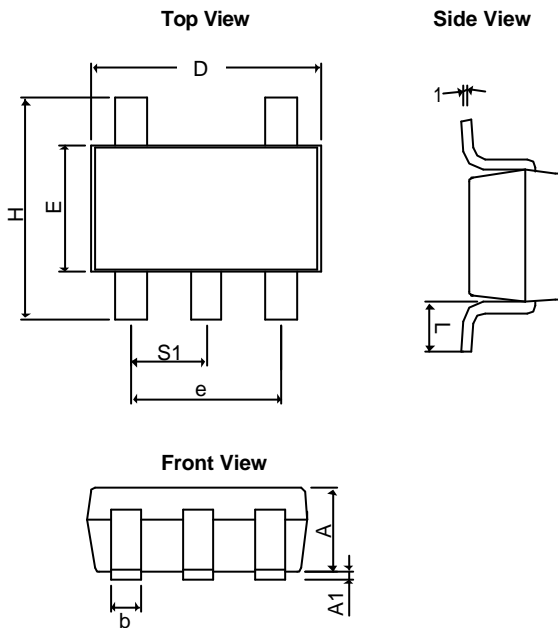
**Carrier Tape, Number of Components Per Reel and Reel Size**

Package	Carrier Width (W)	Pitch (P)	Part Per Full Reel	Reel Size
TSOT-25	8.0±0.1 mm	4.0±0.1 mm	3000pcs	180±1 mm

**■ Package Dimension**
**SOT-25**

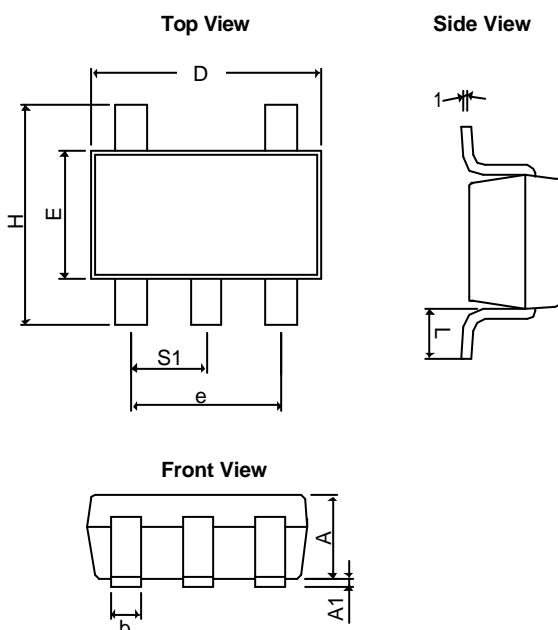
SYMBOLS	MILLIMETERS		INCHES	
	MIN	MAX	MIN	MAX
<b>A</b>	1.20REF		0.0472REF	
<b>A<sub>1</sub></b>	0.00	0.15	0.0000	0.0059
<b>b</b>	0.30	0.55	0.0118	0.0217
<b>D</b>	2.70	3.10	0.1063	0.1220
<b>E</b>	1.40	1.80	0.0551	0.0709
<b>e</b>	1.90 BSC		0.07480 BSC	
<b>H</b>	2.60	3.00	0.10236	0.11811
<b>L</b>	0.37BSC		0.0146BSC	
<b>q1</b>	0°	10°	0°	10°
<b>S<sub>1</sub></b>	0.95BSC		0.0374BSC	

**TSOT-25**

SYMBOLS	MILLIMETERS		INCHES	
	MIN	MAX	MIN	MAX
<b>A+A<sub>1</sub></b>	0.90	1.25	0.0354	0.0492
<b>b</b>	0.30	0.50	0.0118	0.0197
<b>D</b>	2.70	3.10	0.1063	0.1220
<b>E</b>	1.40	1.80	0.0551	0.0709
<b>e</b>	1.90 BSC		0.07480 BSC	
<b>H</b>	2.40	3.00	0.09449	0.11811
<b>L</b>	0.35BSC		0.0138BSC	
<b>q1</b>	0°	10°	0°	10°
<b>S<sub>1</sub></b>	0.95BSC		0.0374BSC	



**www.ame.com.tw**  
**E-Mail: sales@ame.com.tw**

Life Support Policy:

These products of AME, Inc. are not authorized for use as critical components in life-support devices or systems, without the express written approval of the president of AME, Inc.

AME, Inc. reserves the right to make changes in the circuitry and specifications of its devices and advises its customers to obtain the latest version of relevant information.

© AME, Inc. , November 2008

Document: 2006/2095-DS8861-E.05

## **Corporate Headquarter**

### **AME, Inc.**

2F, 302 Rui-Guang Road, Nei-Hu District

Taipei 114, Taiwan.

Tel: 886 2 2627-8687

Fax: 886 2 2659-2989